

HOW TO USE THIS MANUAL

GENERAL INFORMATION

IN00U-44

1. INDEX

An INDEX is provided on the first page of each section to guide you to the item to be repaired. To assist you in finding your way through the manual, the Section Title and major heading are given at the top of every page.

2. PRECAUTION

At the beginning of each section, a PRECAUTION is given that pertains to all repair operations contained in that section.

Read these precautions before starting any repair task.

3. TROUBLESHOOTING

TROUBLESHOOTING tables are included for each system to help you diagnose the problem and find the cause. The fundamentals of how to proceed with troubleshooting are described on [page IN-25](#).

Be sure to read this before performing troubleshooting.

4. PREPARATION

Preparation lists the SST (Special Service Tools), recommended tools, equipment, lubricant and SSM (Special Service Materials) which should be prepared before beginning the operation and explains the purpose of each one.

5. REPAIR PROCEDURES

Most repair operations begin with an overview illustration. It identifies the components and shows how the parts fit together.

Example:

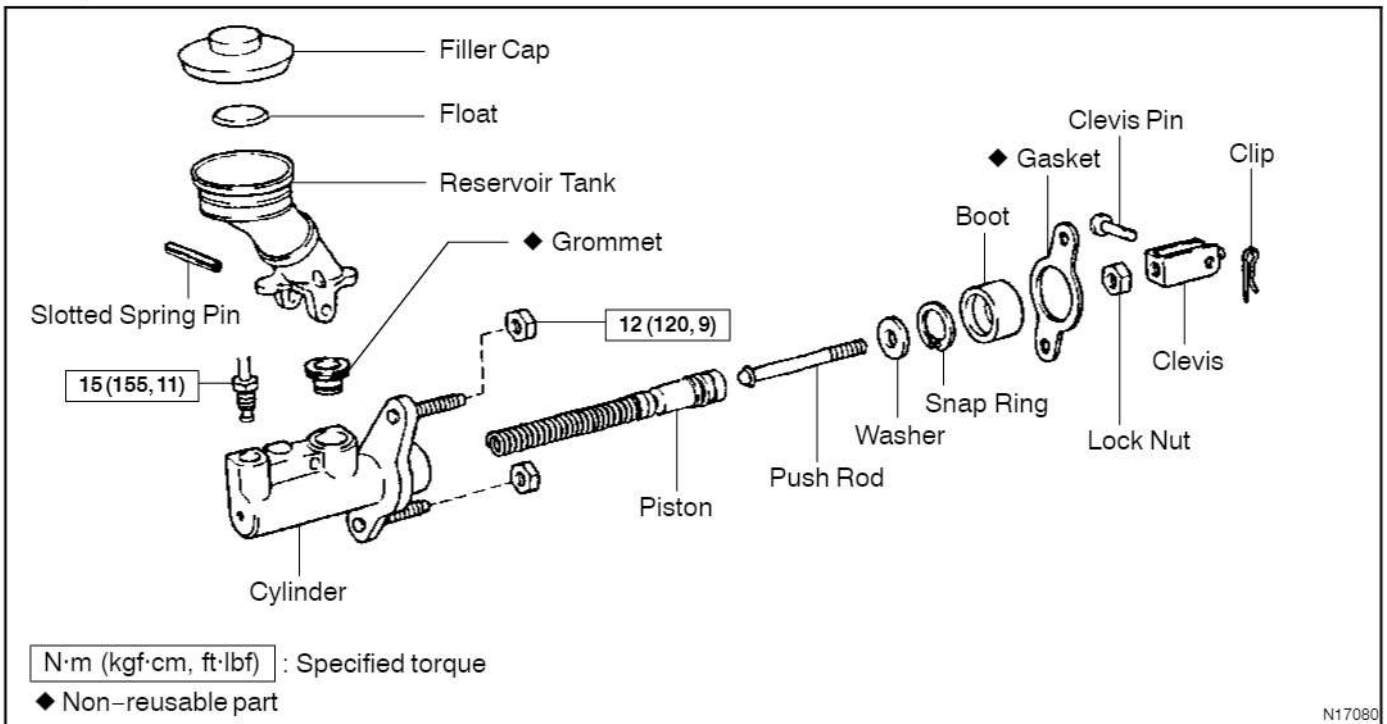

The procedures are presented in a step-by-step format:

- The illustration shows what to do and where to do it.
- The task heading tells what to do.
- The detailed text tells how to perform the task and gives other information such as specifications and warnings.

Example:



- Task heading: what to do*
- 21. CHECK PISTON STROKE OF OVERDRIVE BRAKE**
- (a) Place SST and a dial indicator onto the overdrive brake piston as shown in the illustration.
- SST 09350-30020 (09350-06120)**
- Set part No.* *Component part No.*
- Detailed text: how to do task*
- (b) Measure the stroke applying and releasing the compressed air (392 — 785 kPa, 4 — 8 kgf/cm² or 57 — 114 psi) as shown in the illustration.
- Piston stroke: 1.40 — 1.70 mm (0.0551 — 0.0669 in.)**
- Specification*

This format provides the experienced technician with a FAST TRACK to the information needed. The upper case task heading can be read at a glance when necessary, and the text below it provides detailed information. Important specifications and warnings always stand out in bold type.

6. REFERENCES

References have been kept to a minimum. However, when they are required you are given the page to refer to.

7. SPECIFICATIONS

Specifications are presented in bold type throughout the text where needed. You never have to leave the procedure to look up your specifications. They are also found in Service Specifications section for quick reference.

8. CAUTIONS, NOTICES, HINTS:

- CAUTIONS are presented in bold type, and indicate there is a possibility of injury to you or other people.
- NOTICES are also presented in bold type, and indicate the possibility of damage to the components being repaired.
- HINTS are separated from the text but do not appear in bold. They provide additional information to help you perform the repair efficiently.

9. SI UNIT

The UNITS given in this manual are primarily expressed according to the SI UNIT (International System of Unit), and alternately expressed in the metric system and in the English System.

Example:

Torque: 30 N·m (310 kgf·cm, 22 ft·lbf)

IDENTIFICATION INFORMATION

VEHICLE IDENTIFICATION AND ENGINE SERIAL NUMBER

IN08Y-01

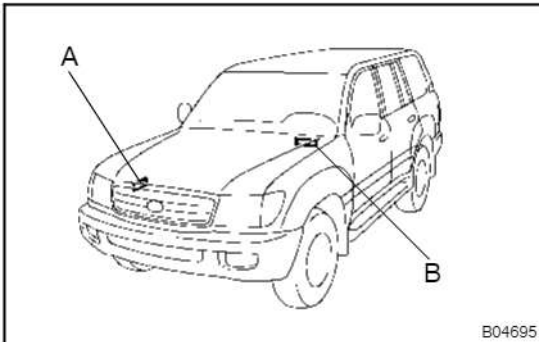

1. VEHICLE IDENTIFICATION NUMBER

The vehicle identification number is stamped on the outer surface of the front right side frame. This number is also stamped on the manufacturer's plate.

A: Vehicle Identification Number

B: Manufacturer's Plate

1FZ-FE Engine:

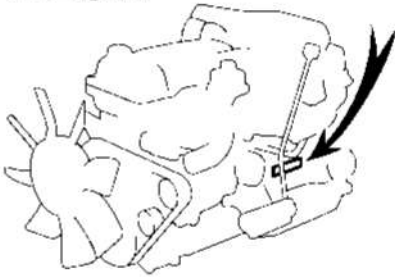

1HZ, 1HD-T and 1HD-FTE Engine:

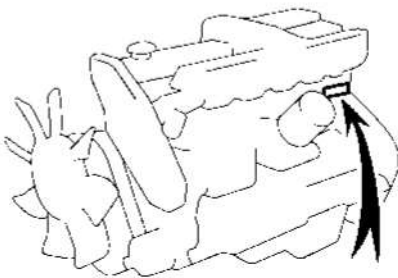

2UZ-FE Engine:

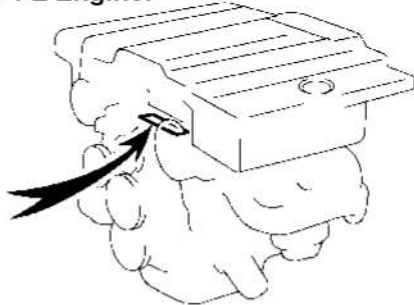

B04691

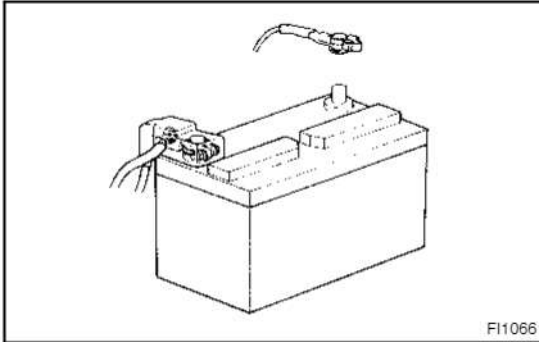

REPAIR INSTRUCTIONS

GENERAL INFORMATION

IN07M-03

BASIC REPAIR HINT

- (a) Use fender, seat and floor covers to keep the vehicle clean and prevent damage.
- (b) During disassembly, keep parts in the appropriate order to facilitate reassembly.
- (c) Installation and removal of battery terminal:
 - (1) Before performing electrical work, disconnect the negative (-) terminal cable from the battery.
 - (2) If it is necessary to disconnect the battery for inspection or repair, first disconnect the negative (-) terminal cable.
 - (3) When disconnecting the terminal cable to prevent damage to battery terminal, loosen the cable nut and raise the cable straight up without twisting or prying it.
 - (4) Clean the battery terminals and cable ends with a clean shop rag. Do not scrape them with a file or other abrasive objects.
 - (5) Install the cable ends to the battery terminals after loosening the nut, and tighten the nut after installation. Do not use a hammer to tap the cable ends onto the terminals.
 - (6) Be sure the cover for the positive (+) terminal is properly in place.
- (d) Check hose and wiring connectors to make sure that they are connected securely and correctly.
- (e) Non-reusable parts
 - (1) Always replace cotter pins, gaskets, O-rings and oil seals, etc. with new ones.
 - (2) Non-reusable parts are indicated in the component illustrations by the "◆" symbol.

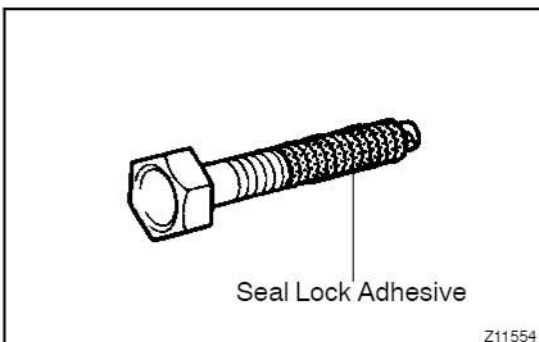

- (f) Precoated parts

Precoated parts are bolts and nuts, etc. that are coated with a seal lock adhesive at the factory.

 - (1) If a precoated part is retightened, loosened or caused to move in any way, it must be recoated with the specified adhesive.
 - (2) When reusing precoated parts, clean off the old adhesive and dry with compressed air. Then apply the specified seal lock adhesive to the bolt, nut or threads.

- (3) Precoated parts are indicated in the component illustrations by the "★" symbol.
- (g) When necessary, use a sealer on gaskets to prevent leaks.
- (h) Carefully observe all specifications for bolt tightening torques. Always use a torque wrench.
- (i) Use of special service tools (SST) and special service materials (SSM) may be required, depending on the nature of the repair. Be sure to use SST and SSM where specified and follow the proper work procedure. A list of SST and SSM can be found in Preparation section in this manual.

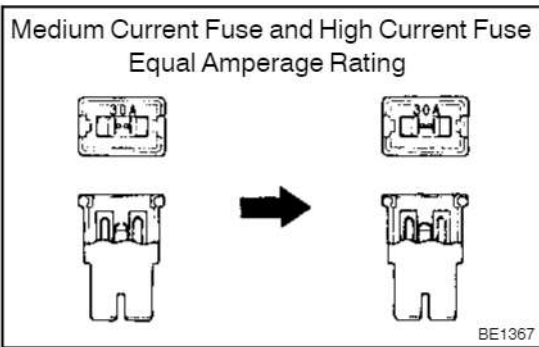

- (j) When replacing fuses, be sure the new fuse has the correct amperage rating. DO NOT exceed the rating or use one with a lower rating.

Illustration	Symbol	Part Name	Abbreviation
 BE5594	 IN0365	FUSE	FUSE
 BE5595	 IN0366	MEDIUM CURRENT FUSE	M-FUSE
 BE5596	 IN0367	HIGH CURRENT FUSE	H-FUSE
 BE5597	 IN0367	FUSIBLE LINK	FL
 BE5598	 IN0368	CIRCUIT BREAKER	CB

- (k) Care must be taken when jacking up and supporting the vehicle. Be sure to lift and support the vehicle at the proper locations (See page IN-8).
- Cancel the parking brake on the level place and shift the transmission in N range.
 - When jacking up the front wheels of the vehicle at first place stoppers behind the rear wheels.
 - When jacking up the rear wheels of the vehicle at first place stoppers before the front wheels.
 - When either the front or rear wheels only should be jacked up, set rigid racks and place stoppers in front and behind the other wheels on the ground.
 - After the vehicle is jacked up, be sure to support it on rigid racks. It is extremely dangerous to do any work on a vehicle raised on a jack alone, even for a small job that can be finished quickly.
- (l) Observe the following precautions to avoid damage to the following parts:
- (1) Do not open the cover or case of the ECU unless absolutely necessary. (If the IC terminals are touched, the IC may be destroyed by static electricity.)

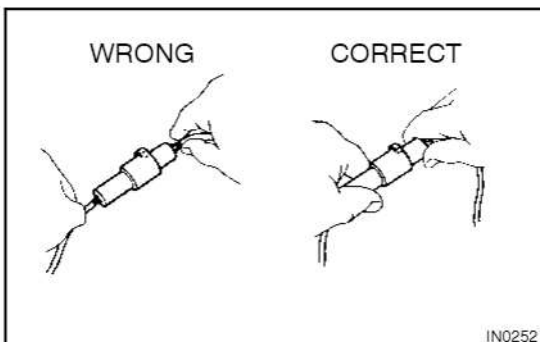
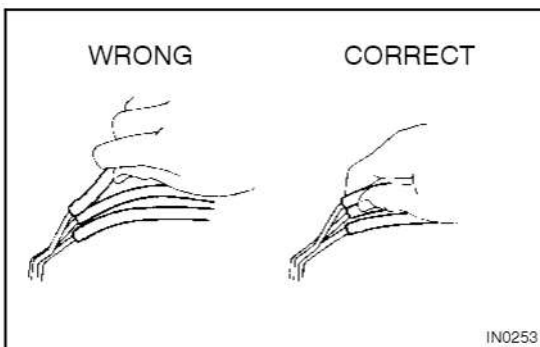

- (2) To disconnect vacuum hoses, pull off the end, not the middle of the hose.
- (3) To pull apart electrical connectors, pull on the connector itself, not the wires.
- (4) Be careful not to drop electrical components, such as sensors or relays. If they are dropped on a hard floor, they should be replaced and not reused.
- (5) When steam cleaning an engine, protect the electronic components, air filter and emission-related components from water.
- (6) Never use an impact wrench to remove or install temperature switches or temperature sensors.
- (7) When checking continuity at the wire connector, insert the tester probe carefully to prevent terminals from bending.
- (8) When using a vacuum gauge, never force the hose onto a connector that is too large. Use a step-down adapter for adjustment. Once the hose has been stretched, it may leak air.

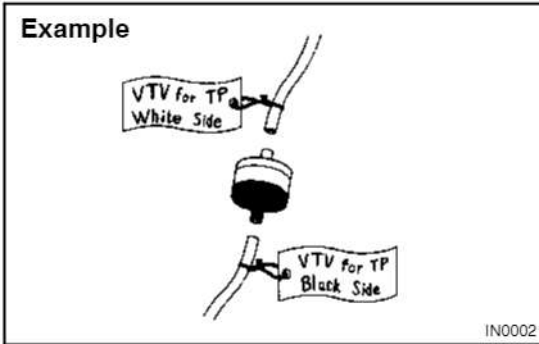

- (m) Installation and removal of vacuum hose:
 - (1) When disconnecting vacuum hoses, use tags to identify how they should be reconnected to.
 - (2) After completing a job, double check that the vacuum hoses are properly connected. A label under the hood shows the proper layout.
- (n) Bleeding of hydraulic brake booster system
When repairing the hydraulic brake booster or ABS, bleeding the air out of the hydraulic brake booster (See page BR-1).
- (o) Unless otherwise stated, all resistance is measured at an ambient temperature of 20°C (68°F). Because the resistance may be outside specifications if measured at high temperatures immediately after the vehicle has been running, measurement should be made when the engine has cooled down.

VEHICLE LIFT AND SUPPORT LOCATIONS

RIGID FRONT SUSPENSION (RFS)

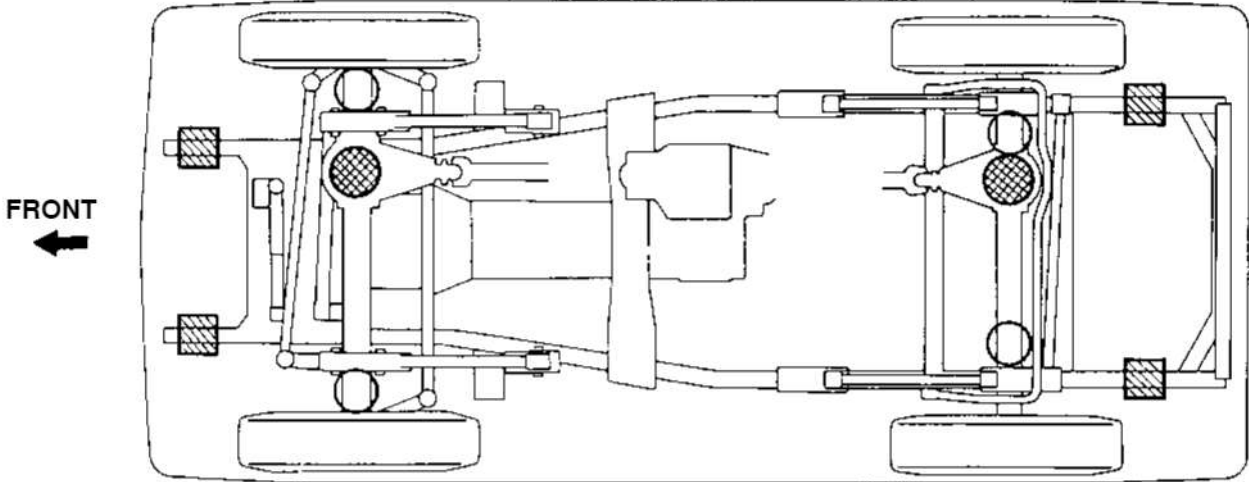

CAUTION : Do not use the swing arm type lift and plate type lift.

JACK POSITION ————— ●

Front Front differential carrier

Rear Rear differential carrier

CAUTION : When jacking-up the front and rear, make sure the car is not carrying any extra weight.

SCREW TYPE JACK POSITION ————— ○

SUPPORT POSITION
Safety stand ▣

cardiagn.com

INDEPENDENT FRONT SUSPENSION (IFS)

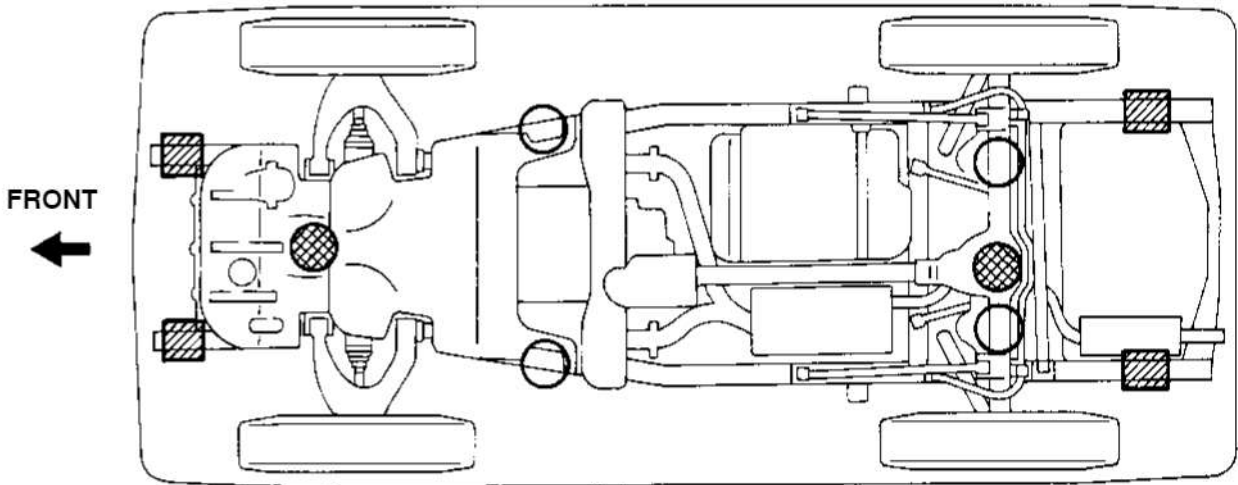

JACK POSITION ————— ●

Front Engine under cover

Rear Rear differential carrier

CAUTION : When jacking-up the front and rear, make sure the car is not carrying any extra weight.

SCREW TYPE JACK POSITION ————— ○

SUPPORT POSITION
Safety stand ▣

NOTICE: (w/ Active Height Control Suspension)
When jacking up the vehicle with the engine running, turn off the active height control suspension with the height control switch pushed.

B04208

cardiagn.com

**INDEPENDENT FRONT SUSPENSION (IFS)
SWING ARM TYPE LIFT**

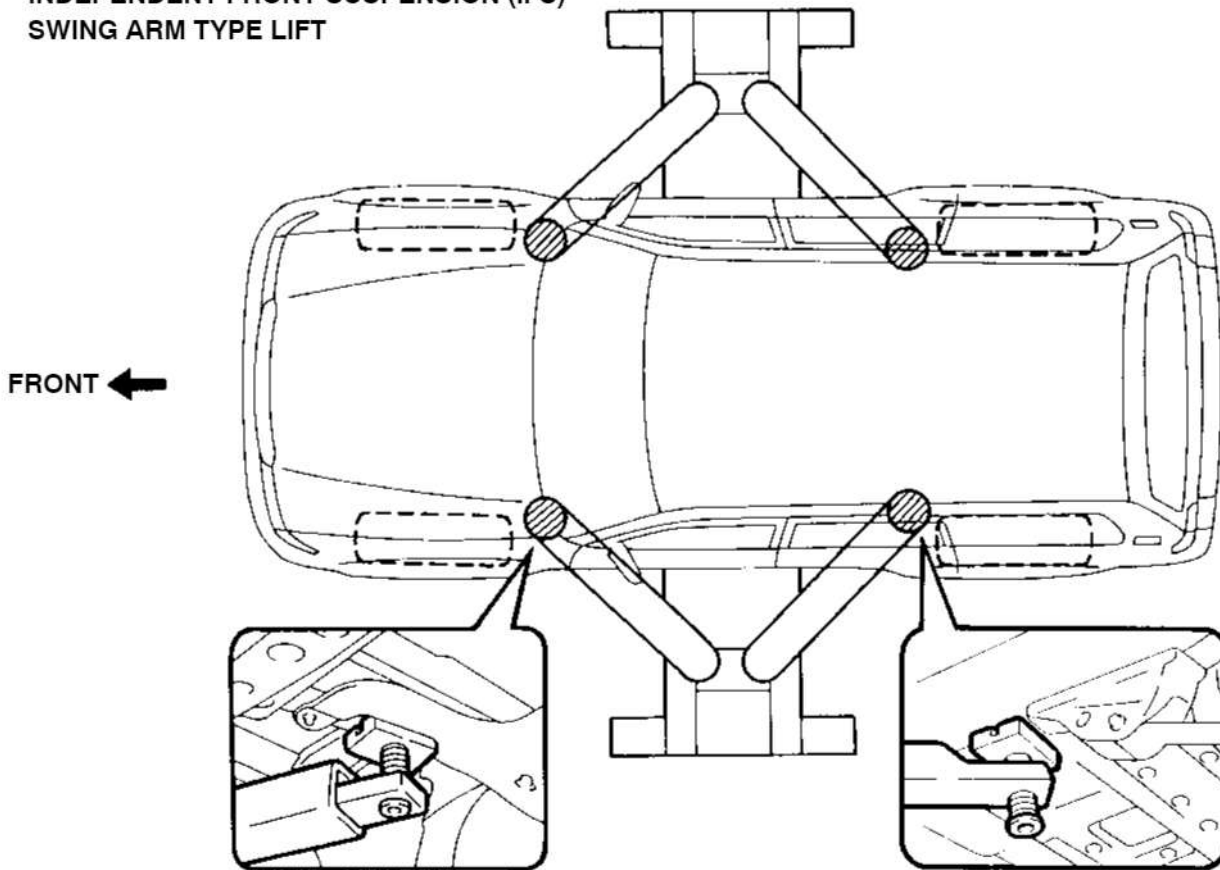

NOTICE: When lifting the vehicle, place the supports correctly at the positions shown above.

PLATE TYPE LIFT (DO NOT USE.)

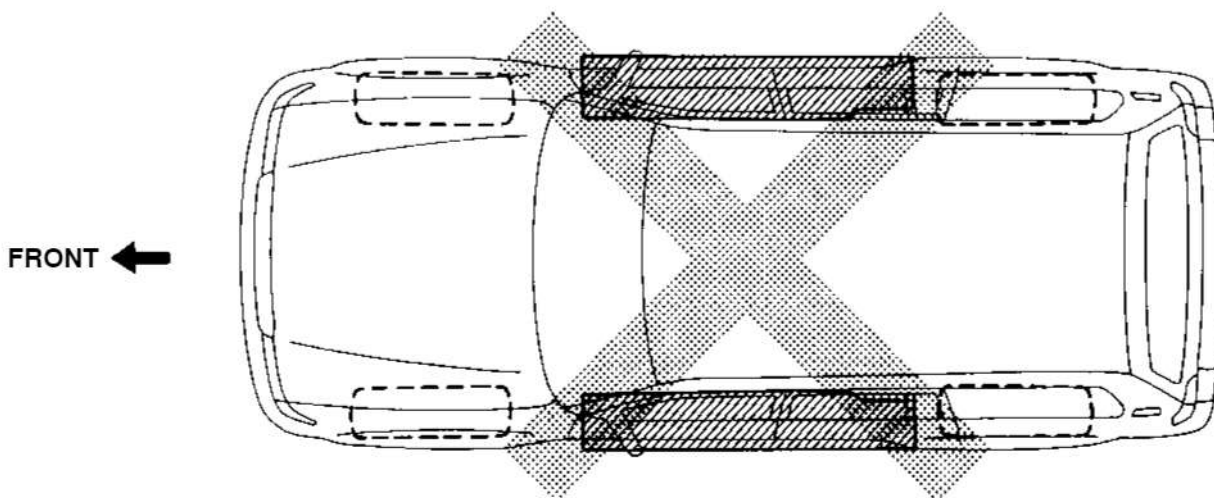

NOTICE: Never use the plate type lift—using it to lift up the vehicle will cause the body shape to warp.

B04209

FOR ALL OF VEHICLES PRECAUTION

IN0EM-02

1. FOR VEHICLES EQUIPPED WITH SRS AIRBAG AND SEAT BELT PRETENSIONER

- (a) The LAND CRUISER is equipped with an SRS (Supplemental Restraint System), such as the driver airbag, front passenger airbag assembly and seat belt pretensioner. Failure to carry out service operations in the correct sequence could cause the supplemental restraint system to unexpectedly deploy during servicing, possibly leading to a serious accident.

Further, if a mistake is made in servicing the supplemental restraint system, it is possible the SRS may fail to operate when required. Before servicing (including removal or installation of parts, inspection or replacement), be sure to read the following items carefully, then follow the correct procedure described in this manual.

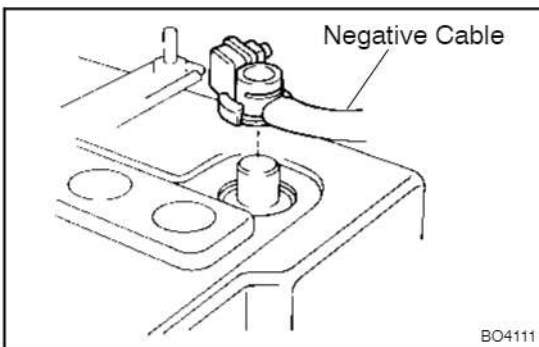

(b) GENERAL NOTICE

- (1) Malfunction symptoms of the supplemental restraint system are difficult to confirm, so the diagnostic trouble codes become the most important source of information when troubleshooting. When troubleshooting the supplemental restraint system, always inspect the diagnostic trouble codes before disconnecting the battery (See Pub. No. RM616E on page DI-447).

- (2) Work must be started after 90 seconds from the time the ignition switch is turned to the "LOCK" position and the negative (-) terminal cable is disconnected from the battery.

(The supplemental restraint system is equipped with a back-up power source so that if work is started within 90 seconds of disconnecting the negative (-) terminal cable from the battery, the SRS may deploy.)

When the negative (-) terminal cable is disconnected from the battery, memory of the clock and audio systems will be cancelled. So before starting work, make a record of the contents memorized by the each memory system. Then when work is finished, reset the clock and audio systems as before. To avoid erasing the memory of each memory system, never use a back-up power supply from another battery.

- (3) Even in cases of a minor collision where the SRS does not deploy, the steering wheel pad, front passenger airbag assembly and seat belt pretensioner should be inspected (See Pub. No. RM616E on page RS-12, RS-26 and BO-213).
- (4) Never use SRS parts from another vehicle. When replacing parts, replace them with new parts.
- (5) Before repairs, remove the airbag sensor if shocks are likely to be applied to the sensor during repairs.
- (6) Never disassemble and repair the airbag sensor assembly, steering wheel pad, front passenger airbag assembly or seat belt pretensioner in order to reuse them.
- (7) If the airbag sensor assembly, steering wheel pad, front passenger airbag assembly or seat belt pretensioner have been dropped, or if there are cracks, dents or other defects in the case, bracket or connector, replace them with new ones.
- (8) Do not directly expose the airbag sensor assembly, steering wheel pad, front passenger airbag assembly or seat belt pretensioner to hot air or flames.
- (9) Use a volt/ohmmeter with high impedance (10 k Ω /V minimum) for troubleshooting of the electrical circuit.
- (10) Information labels are attached to the periphery of the SRS components. Follow the instructions on the notices.
- (11) After work on the supplemental restraint system is completed, check the SRS warning light (See Pub. No. RM616E on page DI-447).

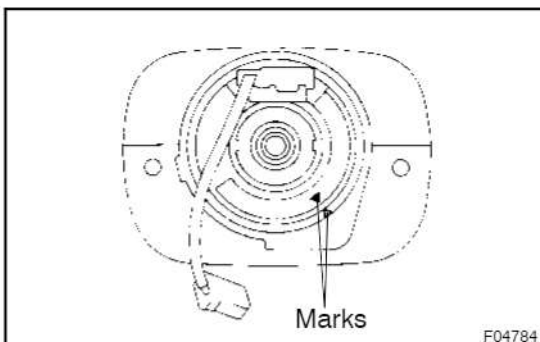

- (c) SPIRAL CABLE (in Combination Switch)
 The steering wheel must be fitted correctly to the steering column with the spiral cable at the neutral position, otherwise cable disconnection and other troubles may result. Refer to Pub. No. RM616E on page SR-37 of this manual concerning correct steering wheel installation.

(d) STEERING WHEEL PAD (with Airbag)

- (1) When removing the steering wheel pad or handling a new steering wheel pad, it should be placed with the pad top surface facing up.
Storing the pad with its metallic surface facing upward may lead to a serious accident if the airbag inflates for some reason. In addition do not store a steering wheel pad on top of another one.
- (2) Never measure the resistance of the airbag squib. (This may cause the airbag to deploy, which is very dangerous.)
- (3) Grease should not be applied to the steering wheel pad and the pad should not be cleaned with detergents of any kind.
- (4) Store the steering wheel pad where the ambient temperature remains below 93°C (200°F), without high humidity and away from electrical noise.
- (5) When using electric welding, first disconnect the airbag connector (yellow color and 2 pins) under the steering column near the combination switch connector before starting work.
- (6) When disposing of a vehicle or the steering wheel pad alone, the airbag should be deployed using an SST before disposal (See Pub. No. RM616E on page RS-14).
Carry out the operation in a safe place away from electrical noise.

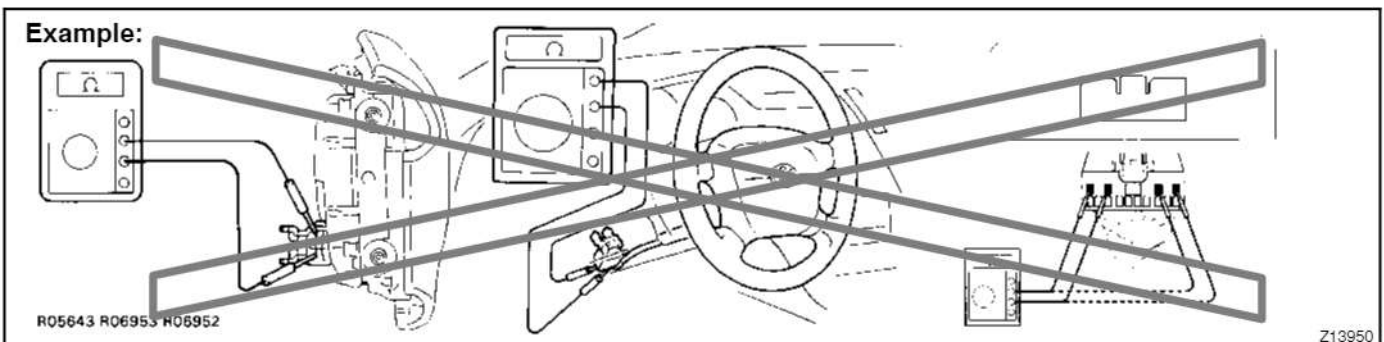
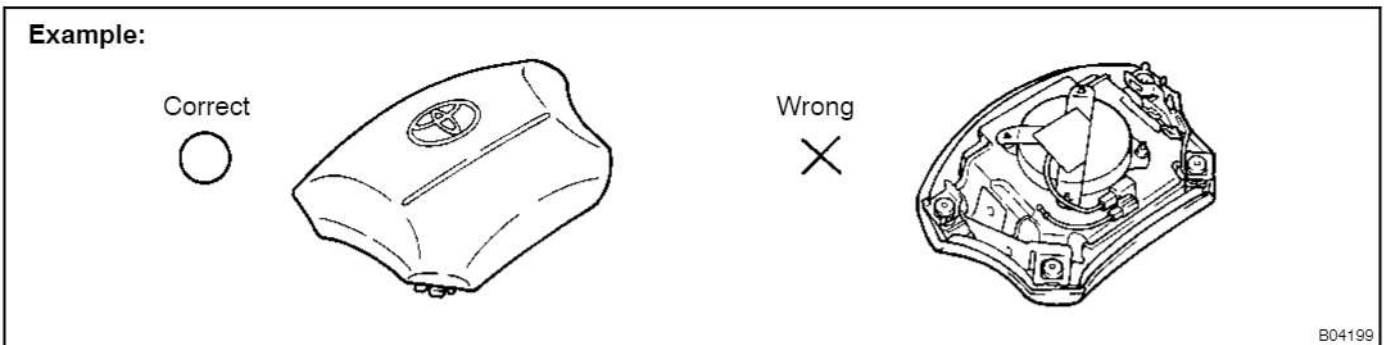

(e) FRONT PASSENGER AIRBAG ASSEMBLY

- (1) Always store a removed or new front passenger airbag assembly with the airbag deployment direction facing up.

Storing the airbag assembly with the airbag deployment direction facing down could cause a serious accident if the airbag inflates.

- (2) Never measure the resistance of the airbag squib. (This may cause the airbag to deploy, which is very dangerous.)
- (3) Grease should not be applied to the front passenger airbag assembly and the airbag door should not be cleaned with detergents of any kind.
- (4) Store the airbag assembly where the ambient temperature remains below 93°C (200°F), without high humidity and away from electrical noise.
- (5) When using electric welding, first disconnect the airbag connector (yellow color and 2 pins) installed on the assembly before starting work.
- (6) When disposing of a vehicle or the airbag assembly alone, the airbag should be deployed using an SST before disposal (See Pub. No. RM616E on page RS-28).

Perform the operation in a safe place away from electrical noise.

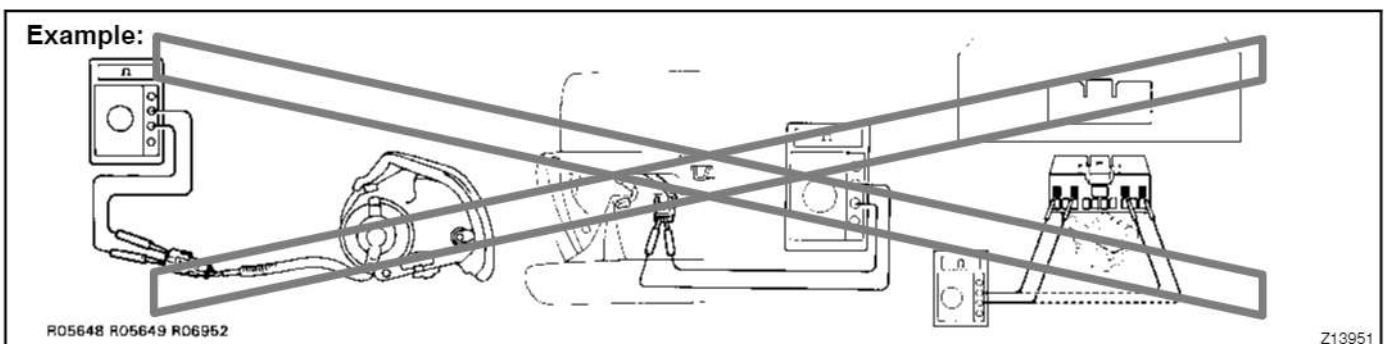
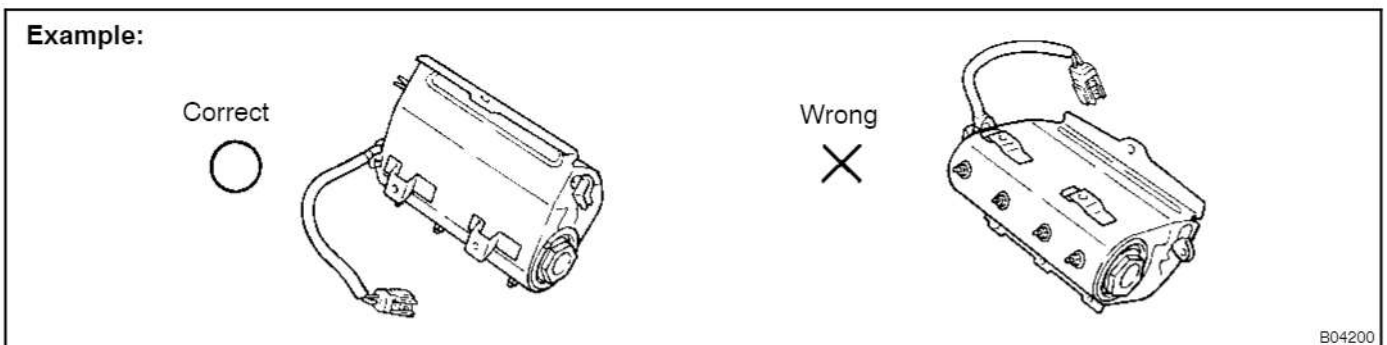

(f) SEAT BELT PRETENSIONER

- (1) Never measure the resistance of the seat belt pretensioner. (This may cause the seat belt pretensioner activation which is very dangerous.)
- (2) Never disassemble the seat belt pretensioner.
- (3) Never install the seat belt pretensioner in another vehicle.
- (4) Store the seat belt pretensioner where the ambient temperature remains below 80°C (176°F) and away from electrical noise without high humidity.
- (5) When using electric welding, first disconnect the connector (yellow color and 2 pins) before starting work.
- (6) When disposing of a vehicle or the seat belt pretensioner alone, the seat belt pretensioner should be activated before disposal (See Pub. No. RM616E on page BO-214). Perform the operation in a safe place away from electrical noise.
- (7) The seat belt pretensioner is hot after activation, so let it cool down sufficiently before the disposal. However never apply water to the seat belt pretensioner.

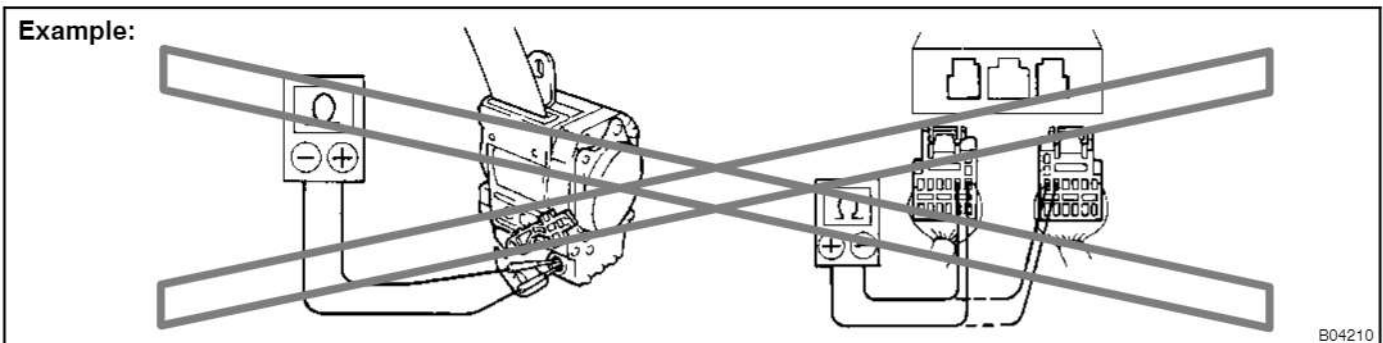

- (g) AIRBAG SENSOR ASSEMBLY
- (1) Never reuse the airbag sensor assembly involved in a collision when the SRS has deployed.
 - (2) The connectors to the airbag sensor assembly should be connected or disconnected with the sensor mounted on the floor. If the connectors are connected or disconnected while the airbag sensor assembly is not mounted to the floor, it could cause undesired ignition of the supplemental restraint system.
 - (3) Work must be started after 90 seconds from the time the ignition switch is turned to the "LOCK" position and the negative (-) terminal cable is disconnected from the battery, even if only loosening the set bolts of the airbag sensor assembly.
- (h) WIRE HARNESS AND CONNECTOR
- The SRS wire harness is integrated with the instrument panel wire harness assembly. The wires for the SRS wire harness are encased in a yellow corrugated tube and all the connectors in the system are a standard yellow color. If the SRS wire harness becomes disconnected or the connector becomes broken due to an accident, etc., repair or replace it.

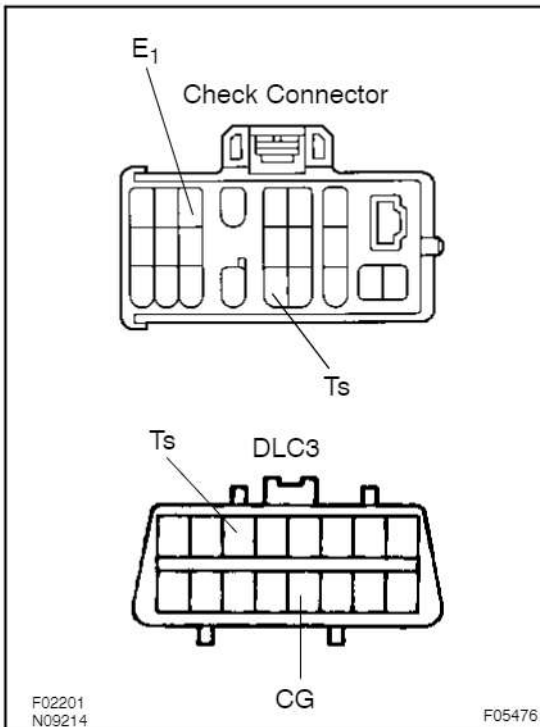

2. FOR VEHICLE EQUIPPED WITH VEHICLE STABILITY CONTROL (VSC) SYSTEM

(a) Precaution when using drum tester:

When using a drum tester, make sure that the ignition switch is OFF, start the engine with the diagnosis connector short-circuited between Ts and E₁ (CG) and take a measurement.

NOTICE:

- Check that VSC warning light is blinking.
- Ensure that the vehicle does not move using wires.
- After the measurement, disconnect the short circuit and check that the VSC warning light is turned off when restarting the engine.

(b) Precaution during VSC operation:

- (1) Since VSC may be affected by the removal/installation of the VSC-related parts, do not remove/install those parts unless absolutely necessary.
- (2) When operating on VSC, follow the instructions in BR section in this manual to surely make preparations or check after operations.

3. WHEN SERVICING FULL-TIME 4WD VEHICLES

The Full-time 4WD LAND CRUISER is equipped with the mechanical lock type center differential system.

During tests using a brake tester or chassis dynamometer, such as braking force tests or speedometer tests, if only the front or rear wheels are to be rotated, it is necessary to set the position of the center differential to FREE or LOCK depending on the type of the test being performed.

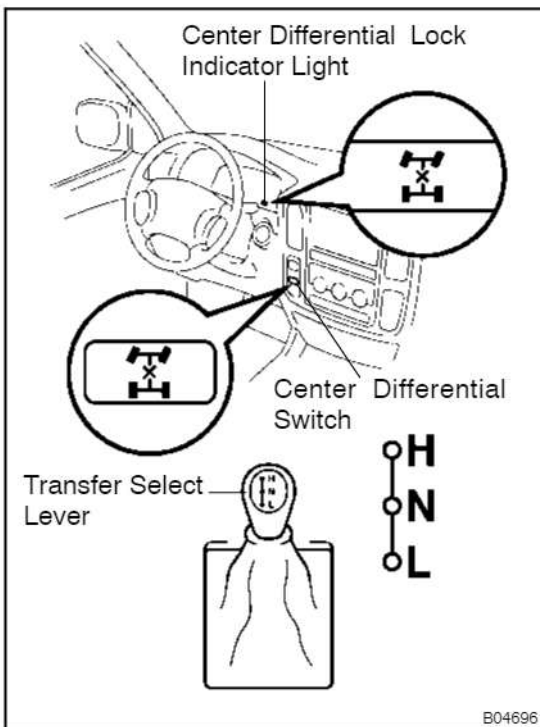

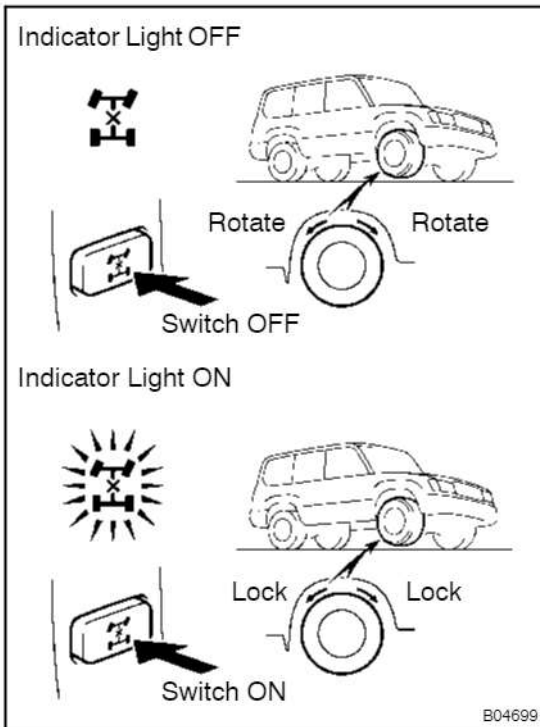

Center differential FREE condition:

	Condition	Wheel
Center differential switch	OFF	A lifted wheel cannot be rotated even if only one wheel is lifted up, as long as transmission is in Neutral (or N range).
Indicator light	OFF	
Transfer select lever (H/L)	w/ VSC: Either will do w/o VSC: H range only	

Center differential LOCK conditions (w/ VSC):

	Condition	Wheel
Center differential switch	ON	A lifted wheel cannot be rotated even if only one wheel is lifted up, as long as transmission is in Neutral (or N range).
Indicator light	ON	
Transfer select lever (H/L)	Either will do	

Center differential LOCK conditions (w/o VSC):

	Condition	Wheel
Center differential switch	ON	A lifted wheel cannot be rotated even if only one wheel is lifted up, as long as transmission is in Neutral (or N range).
Indicator light	ON	
Transfer select lever (H/L)	H position	

	Condition	Wheel
Center differential switch	ON or OFF	A lifted wheel cannot be rotated even if only one wheel is lifted up, as long as transmission is in Neutral (or N range).
Indicator light	ON	
Transfer select lever (H/L)	L position	

HINT:

w/o Vehicle stability control (VSC) system:

When the transfer select lever is put in "L" position, the center differential is put in LOCK condition regardless of the position of the center differential lock switch.

CAUTION:

Center differential "LOCK" ↔ "FREE" selecting procedure:

- Operate the switch only when all of 4 wheels are stopped or driven in a straight line.
- Never operate the switch when any wheel is slipping.
- Never operate the switch when any wheel is spinning freely.
- Never operate the switch when swerving or cornering.

HINT:

- Center differential "LOCK" ↔ "FREE" selecting procedure:
Move the vehicle forward or backward slightly if the indicator light does not operate correctly when the center differential lock switch is turned ON or OFF.

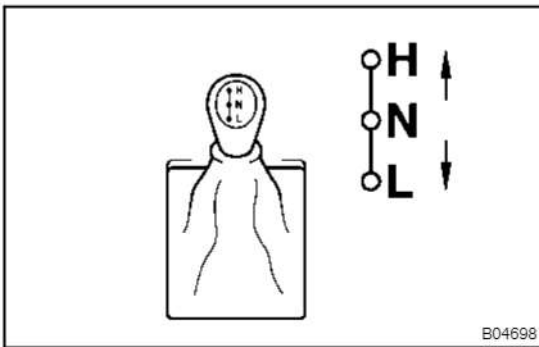

- Transfer gear "H" ↔ "L" gear shifting procedure:
When shifting, always put the shift lever of the transmission in N position. In other positions, the gears of the transfer clash, and switching cannot be performed.

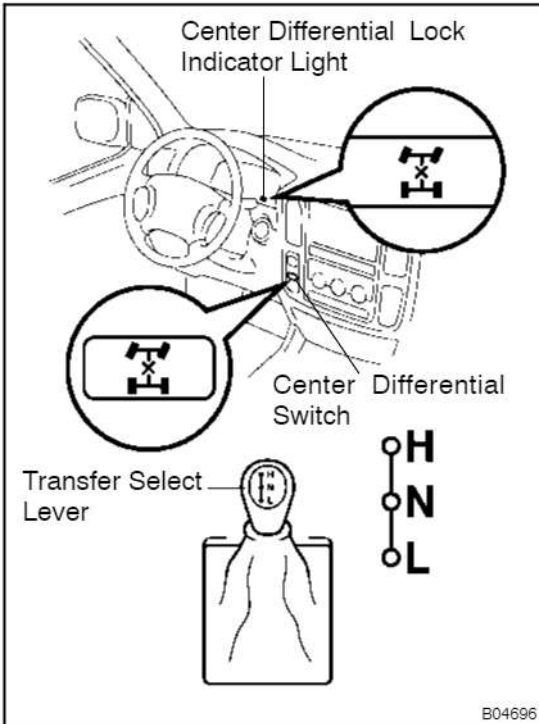

4. WHEN TESTING BRAKES, SPEEDOMETER, ETC.

- (a) When carrying out any kind of servicing or testing on a Full-time 4WD in which the front or rear wheels are to be rotated (braking test, speedometer test), be sure to observe the precautions given below. Incorrect preparations or test procedures may cause danger as well as unsuccessful test results. Before starting any such servicing or test, be sure to check the following items:

- Center differential mode position (FREE or LOCK)

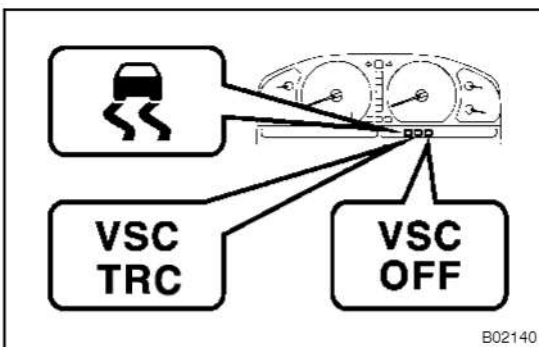

- Vehicle stability control (VSC) system (with or without):
If the vehicle is equipped with the system, the slip indicator light, the VSC/TRC indicator light and the VSC OFF indicator light come on with the ignition key turned to "ON". They will go off after about a few seconds.
- Whether wheels should be touching ground or jacked up
- Transmission gear position (N range)
- Transfer gear position (H or L position)
- Maximum testing vehicle speed
- Maximum testing time

HINT:

w/o Vehicle stability control (VSC) system:

When the transfer select lever is put in "L" position, the center differential is put in LOCK condition regardless of the position of the center differential lock switch.

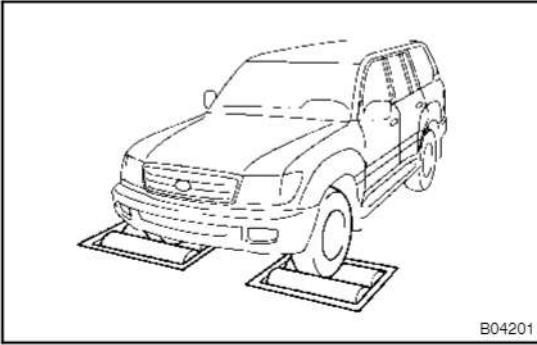

- (b) Using Braking Tester:
 Measure by low-speed type (Vehicle Speed: Below 0.5 km/h or 0.3 mph) brake tester and observe the following instructions before performing the test.
- (1) Position the wheels to be tested (front or rear) on the tester.
 - (2) Put the center differential in FREE position.
 - (3) If the vehicle is equipped with Vehicle Stability Control (VSC) system, prohibit the system from the activation (See step 2.).
 - (4) Shift the transmission shift lever to "N" range.

HINT:

Do not forget to change the Vehicle Stability Control (VSC) & Traction Control (TRC) system to operational condition after the test. Check that the VSC warning indicator light goes off when restarting the engine.

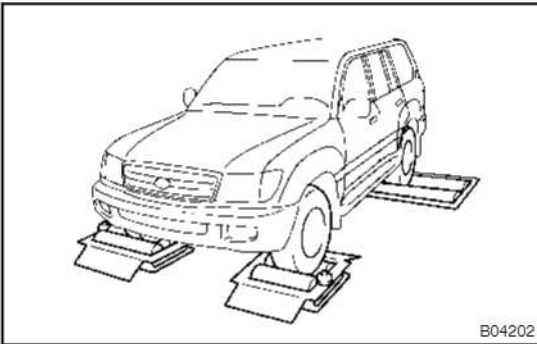

- (c) Using Speedometer Tester:
 Observe the following instructions and then measure with the rear wheels.
- (1) Position the rear wheels on the tester roller.
 - (2) Position the front wheels on the free roller or jack them up.
 - (3) Put the center differential in FREE position.
 - (4) If the vehicle is equipped with Vehicle Stability Control (VSC) & Traction Control (TRC) system, prohibit the system from the activation (See step 2.).
 - (5) Ensure that the vehicle does not move using wires.

CAUTION:

The maximum speed should be less than 60 km/h (37 mph) and maximum driving time should be 1 minute.

HINT:

- Sudden shifting, braking, acceleration or deceleration is not allowed.
- Do not forget to change the Vehicle Stability Control (VSC) & Traction Control (TRC) system to operational condition after the test. Check that the VSC warning indicator light goes off when restarting the engine.

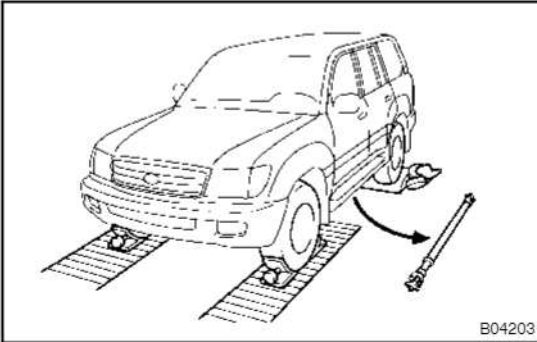

- (d) Using Chassis Dynamometer:
Observe the following instructions and then measure with the rear wheels.
- (1) Remove the front propeller shaft.
 - (2) Put the center differential in LOCK position.
 - (3) If the vehicle is equipped with Vehicle Stability Control (VSC) & Traction Control (TRC) system, prohibit the system from the activation (See step 2.).
 - (4) Ensure that the vehicle is securely fixed.

HINT:

- Sudden shifting, braking, acceleration or deceleration is not allowed.
- Do not forget to change the Vehicle Stability Control (VSC) & Traction Control (TRC) system to operational condition after the test. Check that the VSC warning indicator light goes off when restarting the engine.

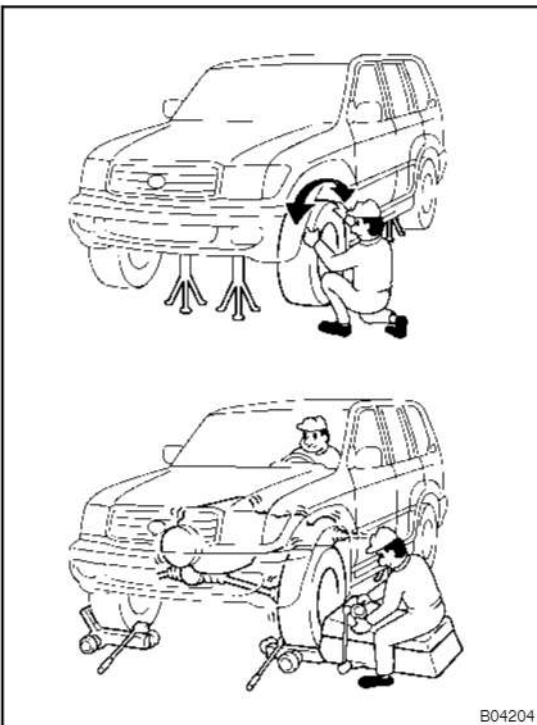

- (e) On-Vehicle Wheel Balancing:
When doing on-vehicle wheel balancing on a full-time 4WD vehicle, to prevent each wheel from being rotated at different speed in different directions (which could damage the center differential), always be sure to observe the following precautions.
- (1) All of 4 wheels should be jacked up, being apart from the ground completely.
 - (2) Put the center differential in LOCK position.
 - (3) If the vehicle is equipped with Vehicle Stability Control (VSC) & Traction Control (TRC) system, prohibit the system from the activation (See step 2.).
 - (4) The parking brake lever should be fully released.
 - (5) None of the brakes should be applied.
 - (6) The wheels should be driven on the wheel balancer with the engine running.
 - (7) Carry out the wheel balancing with the transmission position in D range.

HINT:

- When doing this balancing, pay attention to the other wheels rotating at the same time.
- Sudden acceleration, deceleration or braking is not allowed.
- Do not forget to change the Vehicle Stability Control (VSC) & Traction Control (TRC) system to operational condition after the test. Check that the VSC warning indicator light goes off when restarting the engine.

5. WHEN TOWING FULL-TIME 4WD VEHICLES

- Use one of the methods shown below to tow the vehicle.
- If the vehicle has trouble in the chassis and drive train, use method 1 (flat bed truck).

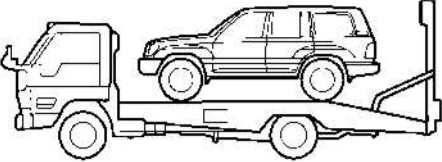
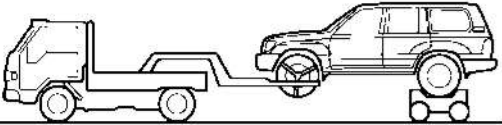
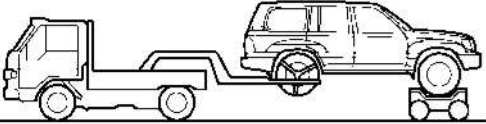
Towing Method	Conditions	Parking Brake	Transmission Shift Lever Position
<p>1. Flat Bed Truck</p> 		Applied	Any Position
<p>2. Wheel Lift Type Truck</p> <p>From Front</p>  <p>From Rear</p> 		Applied	Any Position

B04205

NOTICE:

Do not use any towing method other than those shown above.

- For example, the towing methods shown below are dangerous or damage the vehicle, so do not use them.

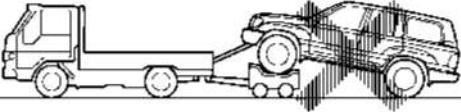
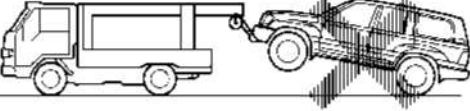
<p style="text-align: center;">NO</p> 	<ul style="list-style-type: none"> • Never tow the vehicle using a method where the lifted-up wheel cannot rotate. • If this towing method is used, either from the front or rear: <ol style="list-style-type: none"> (a) There is a danger of the drive train heating up and causing breakdown, or of the wheels flying off the dolly. (b) In addition, if the vehicle is equipped with the Vehicle Stability Control (VSC) & Traction Control (TRC) system, the system will apply the rotating wheels brake unless the engine isn't shut off.
<p style="text-align: center;">NO</p> 	<p>Do not use the sling type towing method, either from the front or rear, as this method causes damage to the body.</p>

B04206

6. FOR VEHICLES EQUIPPED WITH A CATALYTIC CONVERTER

CAUTION:

If large amount of unburned gasoline flows into the converter, it may overheat and create a fire hazard. To prevent this, observe the following precautions and explain them to your customer.

- (a) Use only unleaded gasoline.
- (b) Avoid prolonged idling.
Avoid running the engine at idle speed for more than 20 minutes.
- (c) Avoid spark jump test.
 - (1) Perform spark jump test only when absolutely necessary. Perform this test as rapidly as possible.
 - (2) While testing, never race the engine.
- (d) Avoid prolonged engine compression measurement.
Engine compression tests must be done as rapidly as possible.
- (e) Do not run engine when fuel tank is nearly empty.
This may cause the engine to misfire and create an extra load on the converter.
- (f) Avoid coasting with ignition turned off and prolonged braking.
- (g) Do not dispose of used catalyst along with parts contaminated with gasoline or oil.

7. IF VEHICLE IS EQUIPPED WITH MOBILE COMMUNICATION SYSTEM

For vehicles with mobile communication systems such as two-way radios and cellular telephones, observe the following precautions.

- (1) Install the antenna as far as possible away from the ECU and sensors of the vehicle's electronic system.
- (2) Install the antenna feeder at least 20 cm (7.87 in.) away from the ECU and sensors of the vehicle's electronic systems. For details about ECU and sensors locations, refer to the section on the applicable component.
- (3) Do not wind the antenna feeder together with the other wiring as much as possible, also avoid running the antenna feeder parallel with other wire harnesses.
- (4) Check that the antenna and feeder are correctly adjusted.
- (5) Do not install powerful mobile communications system.

8. FOR USING HAND-HELD TESTER

CAUTION:

Observe the following items for safety reasons:

- **Before using the hand-held tester, the hand-held tester's operator manual should be read thoroughly.**
- **Be sure to route all cables securely when driving with the hand-held tester connected to the vehicle. (i.e. Keep cables away from feet, pedals, steering wheel and shift lever.)**
- **Two persons are required when test driving with the hand-held tester, one person to drive the vehicle and the other person to operate the hand-held tester.**

HOW TO TROUBLESHOOT ECU CONTROLLED SYSTEMS

IN002-30

GENERAL INFORMATION

A large number of ECU controlled systems are used in the LAND CRUISER. In general, the ECU controlled system is considered to be a very intricate system requiring a high level of technical knowledge and expert skill to troubleshoot. However, the fact is that if you proceed to inspect the circuits one by one, troubleshooting of these systems is not complex. If you have adequate understanding of the system and a basic knowledge of electricity, accurate diagnosis and necessary repair can be performed to locate and fix the problem. This manual is designed through emphasis of the above standpoint to help service technicians perform accurate and effective troubleshooting, and is compiled for the following major ECU controlled systems: The troubleshooting procedure and how to make use of it are described on the following pages.

System	Page
1. ABS & Vehicle Stability Control (VSC) & Brake Assist (BA) System	DI-1

FOR USING HAND-HELD TESTER

- Before using the tester, the tester's operator manual should be read thoroughly.
- If the tester cannot communicate with ECU controlled systems when you have connected the cable of the tester to DLC3, turned the ignition switch ON and operated the tester, there is a problem on the vehicle side or tester side.
 - (1) If communication is normal when the tester is connected to another vehicle, inspect the diagnosis data link line (Bus \oplus line) or ECU power circuit of the vehicle.
 - (2) If communication is still not possible when the tester is connected to another vehicle, the problem is probably in the tester itself, so perform the Self Test procedures outline in the Tester Operator's Manual.

HOW TO PROCEED WITH TROUBLESHOOTING

Carry out troubleshooting in accordance with the procedure on the following page. Here, only the basic procedure is shown. Details are provided in Diagnostics section, showing the most effective methods for each circuit. Confirm the troubleshooting procedures first for the relevant circuit before beginning troubleshooting of that circuit.

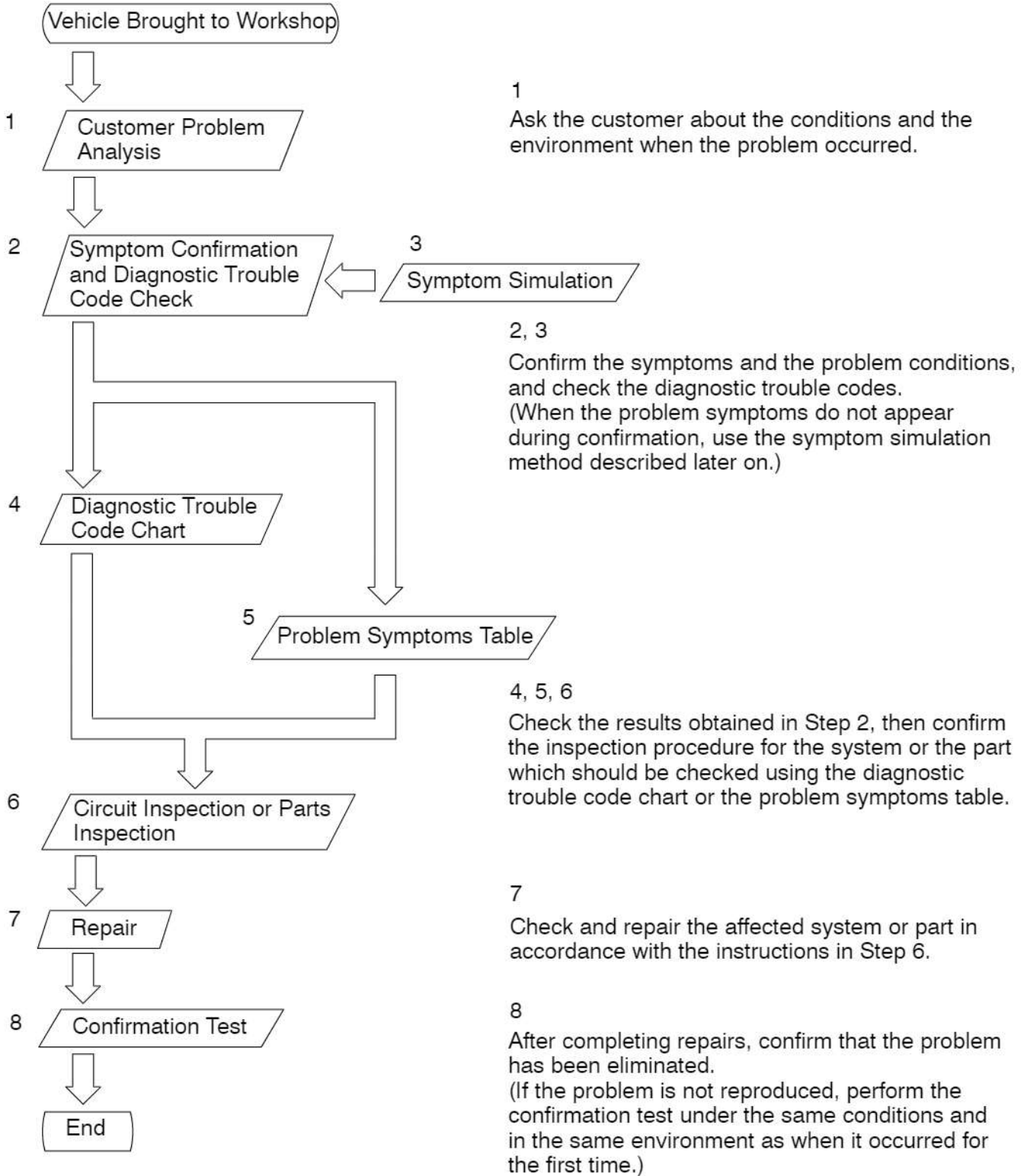

1. CUSTOMER PROBLEM ANALYSIS

In troubleshooting, the problem symptoms must be confirmed accurately and all preconceptions must be cleared away in order to give an accurate judgement. To ascertain just what the problem symptoms are, it is extremely important to ask the customer about the problem and the conditions at the time it occurred.

Important Point in the Problem Analysis:

The following 5 items are important points in the problem analysis. Past problems which are thought to be unrelated and the repair history, etc. may also help in some cases, so as much information as possible should be gathered and its relationship with the problem symptoms should be correctly ascertained for reference in troubleshooting. A customer problem analysis table is provided in Diagnostics section for each system for your use.

Important Points in the Customer Problem Analysis

- What ----- Vehicle model, system name
- When ----- Date, time, occurrence frequency
- Where ----- Road conditions
- Under what conditions? ----- Running conditions, driving conditions, weather conditions
- How did it happen? ----- Problem symptoms

(Sample) Supplemental restraint system check sheet.

CUSTOMER PROBLEM ANALYSIS CHECK			
Supplemental Restraint System Check Sheet		Inspector's Name	
Customer's Name		Registration No.	
		Registration Year	/ /
		Frame No.	
Date Vehicle Brought In	/ /	Odometer Reading	km miles
Date Problem First Occurred	/ /		
Weather	<input type="checkbox"/> Fine <input type="checkbox"/> Cloudy <input type="checkbox"/> Rainy <input type="checkbox"/> Snowy <input type="checkbox"/> Other		
Temperature	Approx.		
Vehicle Operation	<input type="checkbox"/> Starting <input type="checkbox"/> Idling <input type="checkbox"/> Driving [<input type="checkbox"/> Constant speed <input type="checkbox"/> Acceleration <input type="checkbox"/> Deceleration] <input type="checkbox"/> Other		

2. SYMPTOM CONFIRMATION AND DIAGNOSTIC TROUBLE CODE CHECK

The diagnostic system in the LAND CRUISER fulfills various functions. The first function is the Diagnostic Trouble Code Check in which a malfunction in the signal circuits to the ECU is stored in code in the ECU memory at the time of occurrence, to be output by the technician during troubleshooting. Another function is the Input Signal Check which checks if the signals from various switches are sent to the ECU correctly. By using these check functions, the problem areas can be narrowed down quickly and troubleshooting can be performed effectively. Diagnostic functions are incorporated in the following systems in the LAND CRUISER.

System	Diagnostic Trouble Code Check	Input Signal Check (Sensor Check)	Diagnostic Test Mode (Active Test)
ABS & Vehicle Stability Control (VSC) & Brake Assist (BA) System	○	○	○

In diagnostic trouble code check, it is very important to determine whether the problem indicated by the diagnostic trouble code is still occurring or occurred in the past but returned to normal at present. In addition, it must be checked in the problem symptom check whether the malfunction indicated by the diagnostic trouble code is directly related to the problem symptom or not. For this reason, the diagnostic trouble codes should be checked before and after the symptom confirmation to determine the current conditions, as shown in the table below. If this is not done, it may, depending on the case, result in unnecessary troubleshooting for normally operating systems, thus making it more difficult to locate the problem, or in repairs not pertinent to the problem. Therefore, always follow the procedure in correct order and perform the diagnostic trouble code check.

DIAGNOSTIC TROUBLE CODE CHECK PROCEDURE

Diagnostic Trouble Code Check (Make a note of and then clear)	Confirmation of Symptoms	Diagnostic Trouble Code Check	Problem Condition
Diagnostic Trouble Code Display	Problem symptoms exist	Same diagnostic trouble code is displayed	Problem is still occurring in the diagnostic circuit
	No problem symptoms exist	Normal code is displayed	The problem is still occurring in a place other than in the diagnostic circuit (The diagnostic trouble code displayed first is either for a past problem or it is a secondary problem)
Normal Code Display	Problem symptoms exist	Normal code is displayed	The problem is still occurring in a place other than in the diagnostic circuit
	No problem symptoms exist	Normal code is displayed	The problem occurred in a place other than in the diagnostic circuit in the past

Taking into account the points on the previous page, a flow chart showing how to proceed with troubleshooting using the diagnostic trouble code check is shown below. This flow chart shows how to utilize the diagnostic trouble code check effectively, then by carefully checking the results, indicates how to proceed either to diagnostic trouble code troubleshooting or to troubleshooting of problem symptoms table.

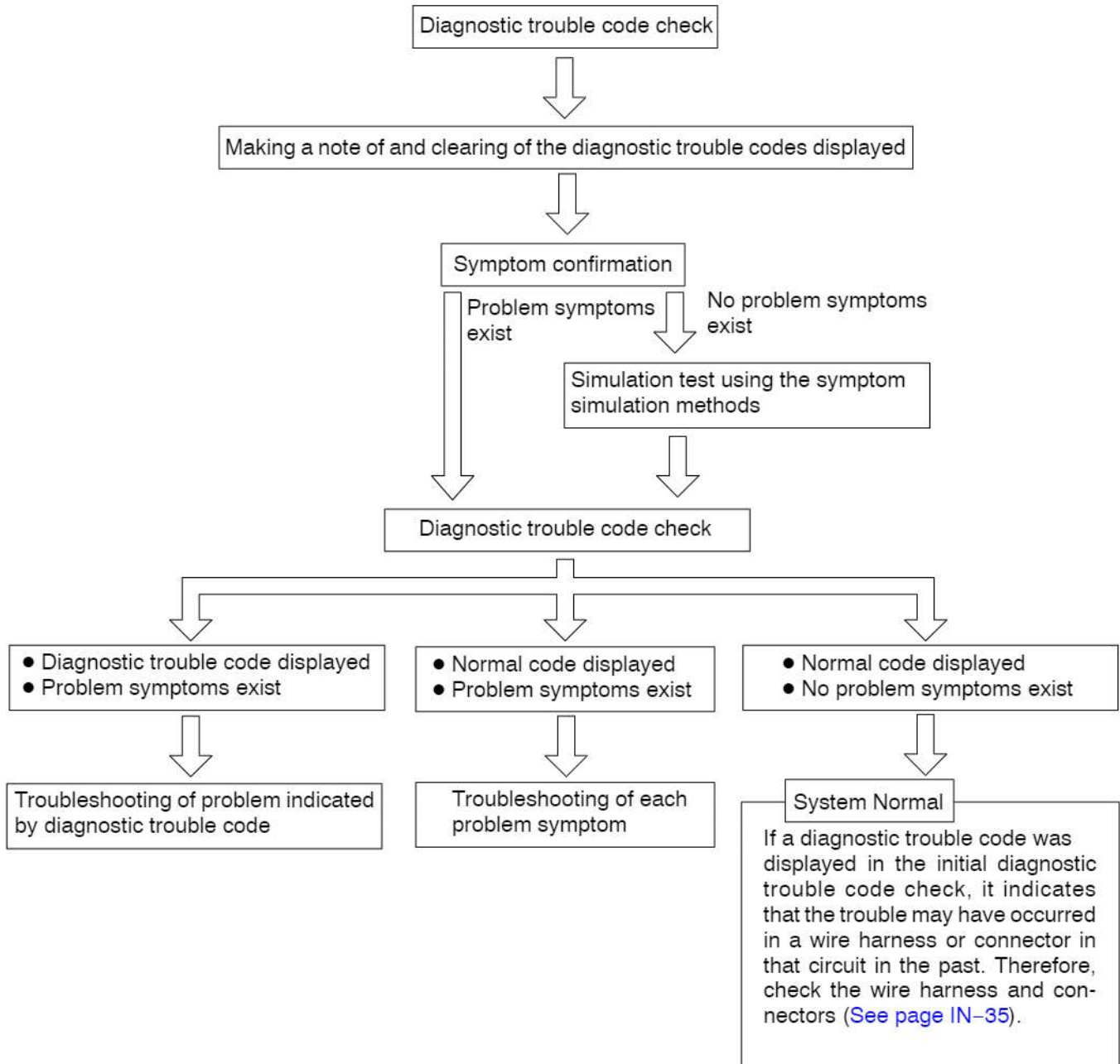

3. SYMPTOM SIMULATION



The most difficult case in troubleshooting is when there are no problem symptoms occurring. In such cases, a thorough customer problem analysis must be carried out, then simulate the same or similar conditions and environment in which the problem occurred in the customer's vehicle. No matter how much experience a technician has, or how skilled he or she may be, if he or she proceeds to troubleshoot without confirming the problem symptoms he or she will tend to overlook something important in the repair operation and make a wrong guess somewhere, which will only lead to a standstill. For example, for a problem which only occurs when the engine is cold, or for a problem which occurs due to vibration caused by the road during driving, etc., the problem can never be determined so long as the symptoms are confirmed with the engine hot condition or the vehicle at a standstill. Since vibration, heat or water penetration (moisture) is likely cause for problem which is difficult to reproduce, the symptom simulation tests introduced here are effective measures in that the external causes are applied to the vehicle in a stopped condition.

Important Points in the Symptom Simulation Test:

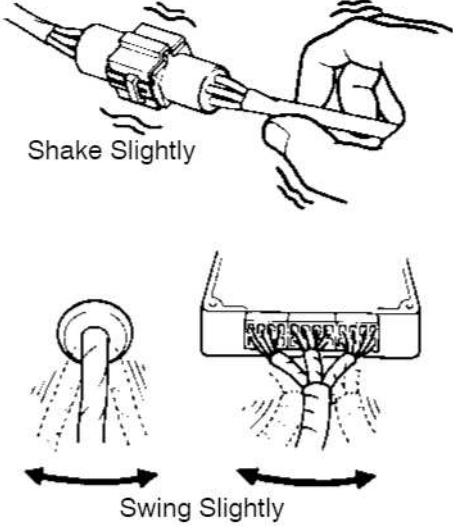
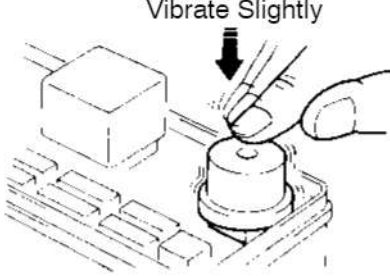
In the symptom simulation test, the problem symptoms should of course be confirmed, but the problem area or parts must also be found out. To do this, narrow down the possible problem circuits according to the symptoms before starting this test and connect a tester beforehand. After that, carry out the symptom simulation test, judging whether the circuit being tested is defective or normal and also confirming the problem symptoms at the same time. Refer to the problem symptoms table for each system to narrow down the possible causes of the symptom.

<p>1</p>	<p>VIBRATION METHOD: When vibration seems to be the major cause.</p>
<p>CONNECTORS Slightly shake the connector vertically and horizontally.</p> <p>WIRE HARNESS Slightly shake the wire harness vertically and horizontally. The connector joint, fulcrum of the vibration, and body through portion are the major areas to be checked thoroughly.</p>	 <p>The diagrams illustrate two vibration methods. The top diagram shows a hand holding a connector and shaking it slightly, labeled 'Shake Slightly'. The bottom diagram shows a hand holding a wire harness and swinging it slightly, labeled 'Swing Slightly'.</p>
<p>PARTS AND SENSOR Apply slight vibration with a finger to the part of the sensor considered to be the problem cause and check that the malfunction occurs.</p> <p>HINT: Applying strong vibration to relays may result in open relays.</p>	 <p>The diagram shows a hand applying slight vibration to a sensor part on a circuit board, labeled 'Vibrate Slightly'.</p>

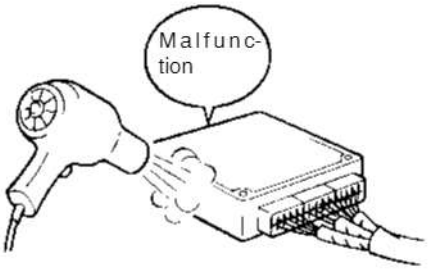
V07268

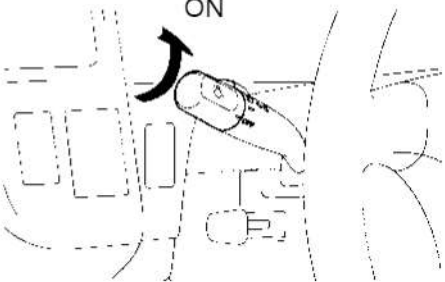
<p>2</p>	<p>HEAT METHOD: When the problem seems to occur when the suspect area is heated.</p>
<p>Heat the component that is the likely cause of the malfunction with a hair dryer or similar object. Check to see if the malfunction occurs.</p> <p>NOTICE:</p> <p>(1) Do not heat to more than 60 °C (140 °F). (Temperature is limited not to damage the components.)</p> <p>(2) Do not apply heat directly to parts in the ECU.</p>	 <p>F12334</p>
<p>3</p>	<p>WATER SPRINKLING METHOD: When the malfunction seems to occur on a rainy day or in a high-humidity condition.</p>
<p>Sprinkle water onto the vehicle and check to see if the malfunction occurs.</p> <p>NOTICE:</p> <p>(1) Never sprinkle water directly into the engine compartment, but indirectly change the temperature and humidity by applying water spray onto the radiator front surface.</p> <p>(2) Never apply water directly onto the electronic components.</p> <p>HINT: If a vehicle is subject to water leakage, the leaked water may contaminate the ECU. When testing a vehicle with a water leakage problem, special caution must be taken.</p>	 <p>F16649</p>
<p>4</p>	<p>OTHER: When a malfunction seems to occur when electrical load is excessive.</p>
<p>Turn on all electrical loads including the heater blower, head lights, rear window defogger, etc. and check to see if the malfunction occurs.</p>	 <p>B02389</p>

cardiagn.com

4. DIAGNOSTIC TROUBLE CODE CHART

The inspection procedure is shown in the table below. This table permits efficient and accurate troubleshooting using the diagnostic trouble codes displayed in the diagnostic trouble code check. Proceed with troubleshooting in accordance with the inspection procedure given in the diagnostic chart corresponding to the diagnostic trouble codes displayed. The Supplemental Restraint System diagnostic trouble code chart is shown below as an example.

● **DTC No.**
Indicates the diagnostic trouble code.

● **Page or Instructions**
Indicates the page where the inspection procedure for each circuit is to be found, or gives instructions for checking and repairs.

● **Trouble Area**
Indicates the suspect area of the problem.

● **Detection Item**
Indicates the system of the problem or contents of the problem.

DIAGNOSTIC TROUBLE CODE CHART
If a malfunction code is displayed during the DTC check, check the circuit for that code listed in the table below. (Proceed to the page given for that circuit).

DTC No. (See page)	Detection Item	Trouble Area	SRS Warning Light
B0100/13 (DI-119)	● Short in D squib circuit	<ul style="list-style-type: none"> ● Steering wheel pad (squib) ● Spiral cable ● Airbag sensor assembly ● Wire harness 	ON
B0101/14 (DI-124)	● Open in D squib circuit	<ul style="list-style-type: none"> ● Steering wheel pad (squib) ● Spiral cable ● Airbag sensor assembly ● Wire harness 	ON
B0102/11 (DI-128)	● Short in D squib circuit (to ground)	<ul style="list-style-type: none"> ● Steering wheel pad (squib) ● Spiral cable ● Airbag sensor assembly ● Wire harness 	ON
B0103/12 (DI-132)	● Short in D squib circuit (to B+)	<ul style="list-style-type: none"> ● Steering wheel pad (squib) ● Spiral cable ● Airbag sensor assembly ● Wire harness 	ON
B0105/53 (DI-136)	● Short in P squib circuit	<ul style="list-style-type: none"> ● Front Passenger airbag assembly (squib) ● Airbag sensor assembly ● Wire harness 	ON
B0106/54	● Open in P squib circuit	<ul style="list-style-type: none"> ● Front Passenger airbag assembly (squib) ● Airbag sensor assembly ● Wire harness 	
	● Short in P squib circuit (to Ground)	<ul style="list-style-type: none"> ● Front Passenger airbag assembly (squib) ● Airbag sensor assembly ● Wire harness 	

5. PROBLEM SYMPTOMS TABLE

The suspected circuits or parts for each problem symptom are shown in the table below. Use this table to troubleshoot the problem when a "Normal" code is displayed in the diagnostic trouble code check but the problem is still occurring. Numbers in the table indicate the inspection order in which the circuits or parts should be checked.

HINT:

When the problem is not detected by the diagnostic system even though the problem symptom is present, it is considered that the problem is occurring outside the detection range of the diagnostic system, or that the problem is occurring in a system other than the diagnostic system.

● Page
Indicates the page where the flow chart for each circuit is located.

● Circuit Inspection, Inspection Order
Indicates the circuit which needs to be checked for each problem symptom. Check in the order indicated by the numbers.

● Problem Symptom

● Circuit or Part Name
Indicates the circuit or part which needs to be checked.

PROBLEM SYMPTOMS TABLE
Proceed with troubleshooting of each circuit in the table below.

Symptom	Suspect Area	See page
<ul style="list-style-type: none"> With the ignition switch in the ACC or ON position, the SRS warning light sometimes lights up after approx. 6 seconds have elapsed. SRS warning light is always lit up even when ignition switch is in the LOCK position 	<ul style="list-style-type: none"> SRS warning light circuit (Always lights up when ignition switch is in LOCK position.) 	DI-180
<ul style="list-style-type: none"> With the ignition switch in the ACC or ON position, the SRS warning light does not light up. 	<ul style="list-style-type: none"> SRS warning light circuit (Does not light up when ignition switch is turned to ACC or ON.) 	DI-183
<ul style="list-style-type: none"> DTC is not displayed. SRS warning light is always lit up at the time of DTC check procedure. DTC is displayed without Tc and E1 terminal connection. 	<ul style="list-style-type: none"> Tc terminal circuit 	DI-187

cardiagn.com

6. CIRCUIT INSPECTION

How to read and use each page is shown below.

● Diagnostic Trouble Code No. and Detection Item

● Circuit Description
The major role and operation, etc. of the circuit and its component parts are explained.

DTC	B0100/13	Short in D Squib Circuit
------------	-----------------	---------------------------------

CIRCUIT DESCRIPTION

The D squib circuit consists of the airbag sensor assembly, spiral cable and steering wheel pad.

It causes the airbag to deploy when the airbag deployment conditions are satisfied.

For details of the function of each components, see OPERATION on page RS-2.

DTC B0100/13 is recorded when a short is detected in the D squib circuit.

DTC No.	DTC Detecting Condition	Trouble Area
B010013	<ul style="list-style-type: none"> • Short circuit between D+ wire harness and D- wire harness of squib • D squib malfunction • Spiral cable malfunction • Airbag sensor assembly malfunction 	<ul style="list-style-type: none"> • Steering wheel pad (D squib) • Spiral cable • Airbag sensor assembly • Wire harness

● Indicates the diagnostic trouble code, diagnostic trouble code set parameter and suspect area of the problem.

WIRING DIAGRAM

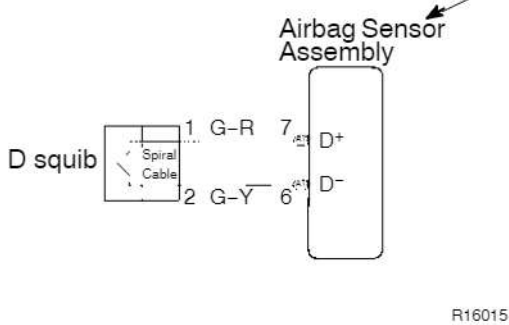

● Wiring Diagram

This shows a wiring diagram of the circuit. Use this diagram together with ELECTRICAL WIRING DIAGRAM to thoroughly understand the circuit.

Wire colors are indicated by an alphabetical code. B = Black, L = Blue, R = Red, BR = Brown, LG = Light Green, V = Violet, G = Green, O = Orange, W = White, GR = Gray, P = Pink, Y = Yellow, SB = Sky Blue

The first letter indicates the basic wire color and the second letter indicates the color of the stripe.

cardiagn.com

- Indicates the position of the ignition switch during the check.

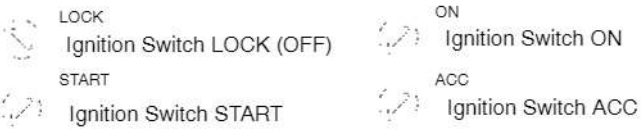

- Inspection Procedure
Use the inspection procedure to determine if the circuit is normal or abnormal, and if it is abnormal, use it to determine whether the problem is located in the sensors, actuators, wire harness or ECU.

INSPECTION PROCEDURE

2 Check voltage at IG2 and ACC of airbag sensor assembly.

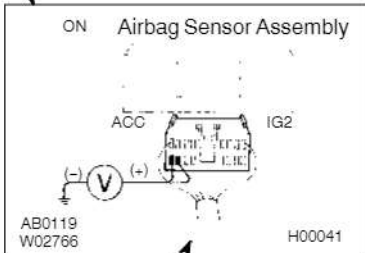

PREPARATION:

Turn ignition switch ON.

CHECK:

Measure voltage between terminals IG2 and ACC of airbag sensor assembly and body ground.

OK:

Voltage: Below 16 V

OK

NG

**Check battery and charging system.
(See charging system section)**

- Indicates the place to check the voltage or resistance.
- Indicates the connector position to be checked, from the front or back side.

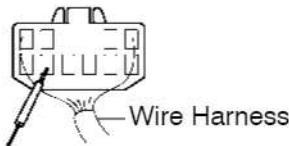

Check from the connector back side.
(with harness)



Check from the connector front side. (without harness)
In this case, care must be taken not to bend the terminals.

- Indicates the condition of the connector of ECU during the check.

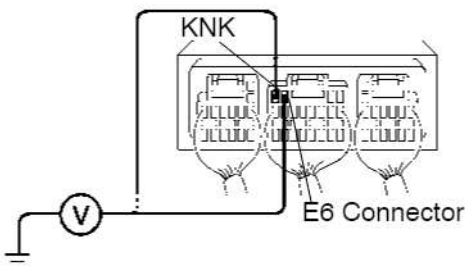

Connector being checked is connected.

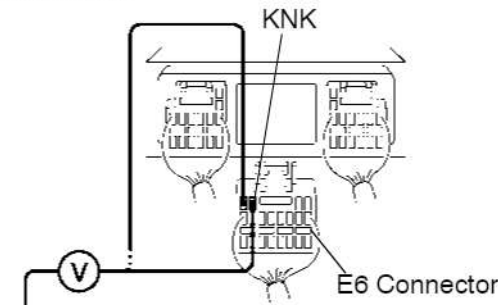

Connector being checked is disconnected.

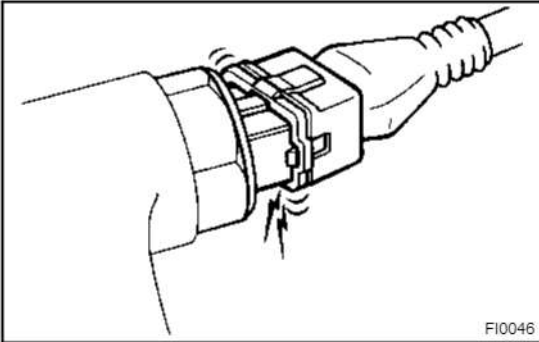

F10046

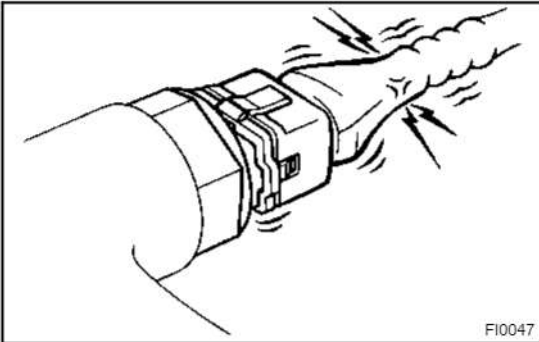

F10047

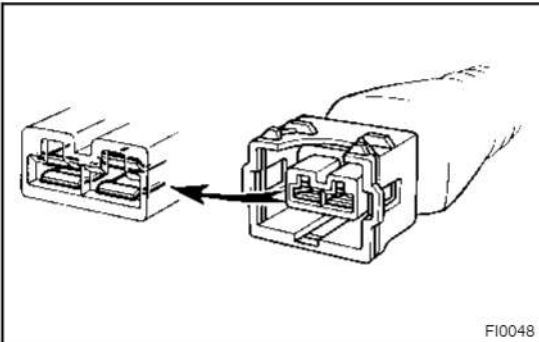

F10048

HOW TO USE THE DIAGNOSTIC CHART AND INSPECTION PROCEDURE

1. CONNECTOR CONNECTION AND TERMINAL INSPECTION

- For troubleshooting, diagnostic trouble code charts or problem symptom table are provided for each circuit with detailed inspection procedures on the following pages.
- When all the component parts, wire harnesses and connectors of each circuit except the ECU are found to be normal in troubleshooting, then it is determined that the problem is in the ECU. Accordingly, if diagnosis is performed without the problem symptoms occurring, refer to Step 8 to replace the ECU. So always confirm that the problem symptoms are occurring, or proceed with inspection while using the symptom simulation method.
- The instructions "Check wire harness and connector" and "Check and replace ECU" which appear in the inspection procedure, are common and applicable to all diagnostic trouble codes. Follow the procedure outlined below whenever these instructions appear.

OPEN CIRCUIT:

This could be due to a disconnected wire harness, faulty contact in the connector, and a connector terminal pulled out, etc.

HINT:

- It is rarely the case that a wire is broken in the middle of it. Most cases occur at the connector. In particular, carefully check the connectors of sensors and actuators.
- Faulty contact could be due to rusting of the connector terminals, to foreign materials entering terminals or a deformation of connector terminals. Simply disconnecting and reconnecting the connectors once changes the condition of the connection and may result in a return to normal operation. Therefore, in troubleshooting, if no abnormality is found in the wire harness and connector check, but the problem disappears after the check, then the cause is considered to be in the wire harness or connectors.

SHORT CIRCUIT:

This could be due to a contact between wire harness and the body ground or to a short circuit occurred inside the switch, etc.

HINT:

When there is a short circuit between the wire harness and body ground, check thoroughly whether the wire harness is caught in the body or is clamped properly.

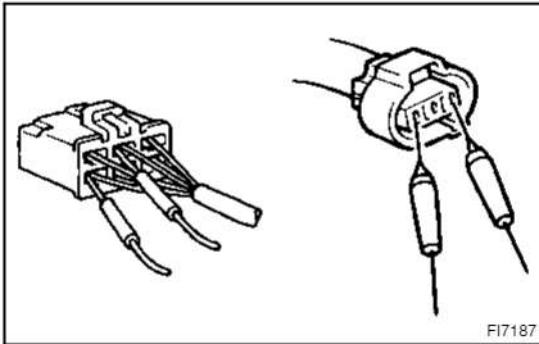

2. CONNECTOR HANDLING

When inserting tester probes into a connector, insert them from the rear of the connector. When necessary, use mini test leads. For water resistant connectors which cannot be accessed from behind, take good care not to deform the connector terminals.

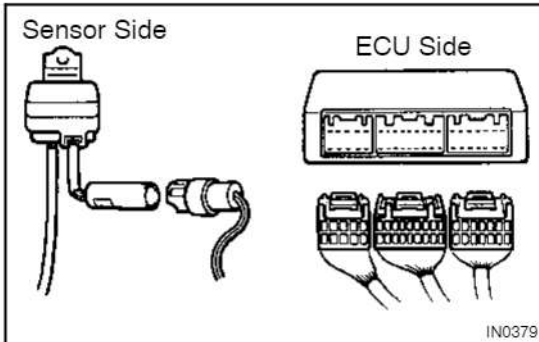

3. CONTINUITY CHECK (OPEN CIRCUIT CHECK)

- Disconnect the connectors at both ECU and sensor sides.
- Measure the resistance between the applicable terminals of the connectors.

Resistance: 1 Ω or less

HINT:

Measure the resistance while lightly shaking the wire harness vertically and horizontally.

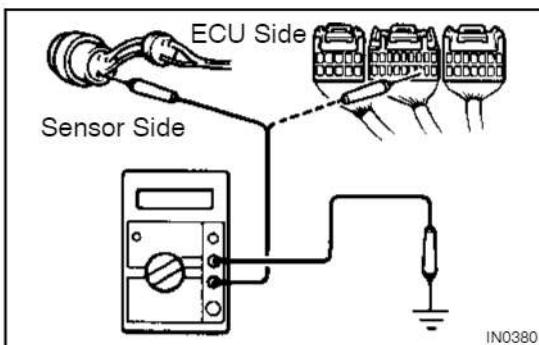
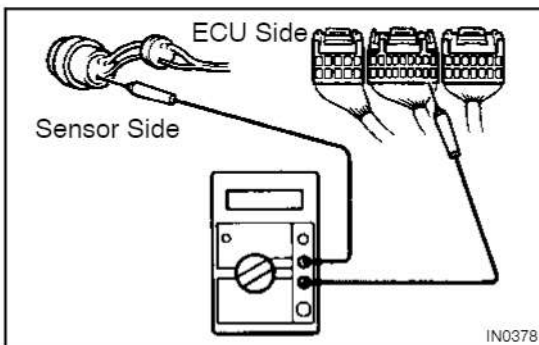

4. RESISTANCE CHECK (SHORT CIRCUIT CHECK)

- Disconnect the connectors on both ends.
- Measure the resistance between the applicable terminals of the connectors and body ground. Be sure to carry out this check on the connectors on both ends.

Resistance: 1 M Ω or higher

HINT:

Measure the resistance while lightly shaking the wire harness vertically and horizontally.

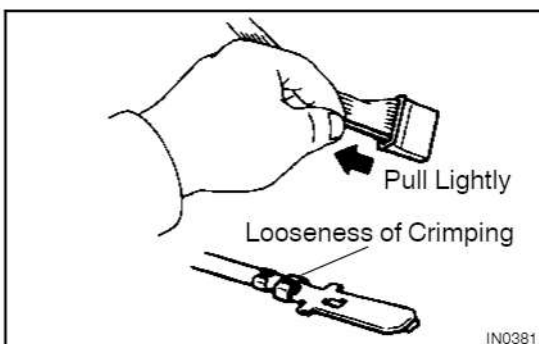

5. VISUAL CHECK AND CONTACT PRESSURE CHECK

- Disconnect the connectors at both ends.
- Check for rust or foreign material, etc. in the terminals of the connectors.
- Check crimped portions for looseness or damage and check that the terminals are secured in lock portion.

HINT:

The terminals should not come out when pulled lightly from the back.

- (d) Prepare a test male terminal and insert it in the female terminal, then pull it out.

NOTICE:

When testing a gold-plated female terminal, always use a gold-plated male terminal.

HINT:

When the test terminal is pulled out more easily than others, there may be poor contact in that section.

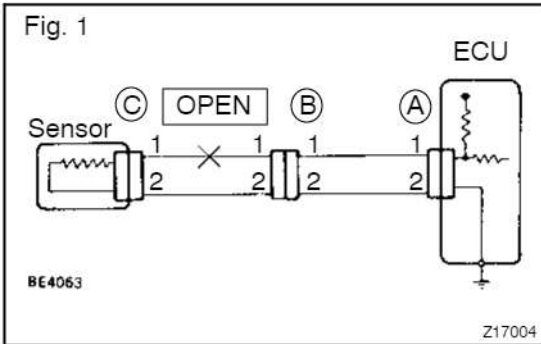

6. CHECK OPEN CIRCUIT

For the open circuit in the wire harness in Fig. 1, perform "(a) Continuity Check" or "(b) Voltage Check" to locate the section.

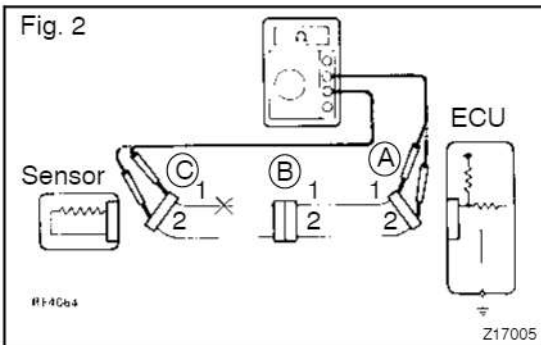

- (a) Check the continuity.

- (1) Disconnect connectors "A" and "C" and measure the resistance between them.

In the case of Fig. 2:

Between terminal 1 of connector "A" and terminal 1 of connector "C" → No continuity (open)

Between terminal 2 of connector "A" and terminal 2 of connector "C" → Continuity

Therefore, it is found out that there is an open circuit between terminal 1 of connector "A" and terminal 1 of connector "C".

- (2) Disconnect connector "B" and measure the resistance between the connectors.

In the case of Fig. 3:

Between terminal 1 of connector "A" and terminal 1 of connector "B1" → Continuity

Between terminal 1 of connector "B2" and terminal 1 of connector "C" → No continuity (open)

Therefore, it is found out that there is an open circuit between terminal 1 of connector "B2" and terminal 1 of connector "C".

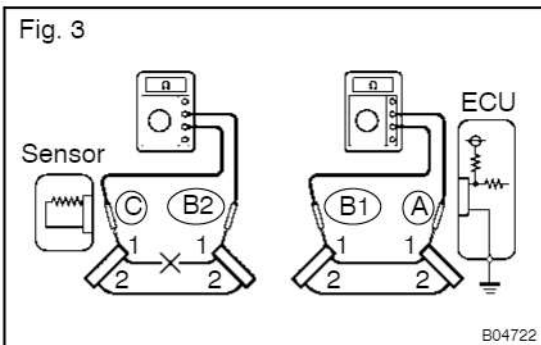

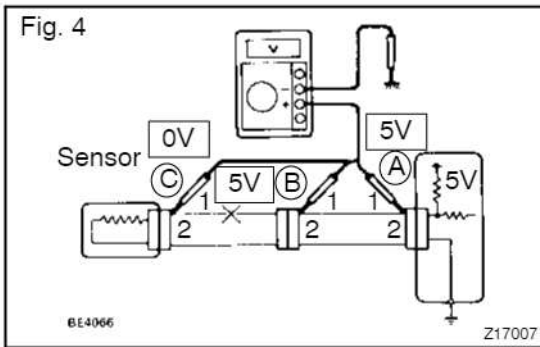

(b) Check the voltage.

In a circuit in which voltage is applied (to the ECU connector terminal), an open circuit can be checked for by conducting a voltage check.

As shown in Fig. 4, with each connector still connected, measure the voltage between body ground and terminal 1 of connector "A" at the ECU 5V output terminal, terminal 1 of connector "B", and terminal 1 of connector "C", in that order.

If the results are:

5V: Between Terminal 1 of connector "A" and Body Ground
 5V: Between Terminal 1 of connector "B" and Body Ground
 0V: Between Terminal 1 of connector "C" and Body Ground
 Then it is found out that there is an open circuit in the wire harness between terminal 1 of "B" and terminal 1 of "C".

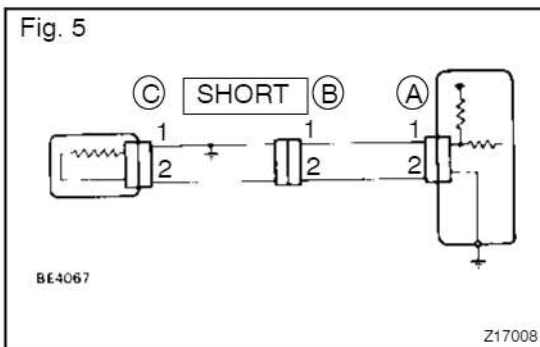
**7. CHECK SHORT CIRCUIT**

If the wire harness is ground shorted as in Fig. 5, locate the section by conducting a "continuity check with ground".

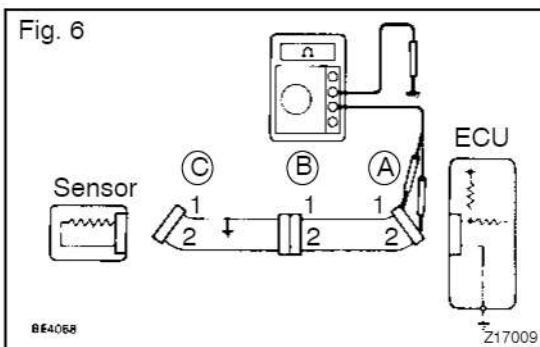

Check the continuity with ground.

- (1) Disconnect connectors "A" and "C" and measure the resistance between terminal 1 and 2 of connector "A" and body ground.

In the case of Fig. 6:

Between terminal 1 of connector "A" and body ground → Continuity (short)

Between terminal 2 of connector "A" and body ground → No continuity

Therefore, it is found out that there is a short circuit between terminal 1 of connector "A" and terminal 1 of connector "C".

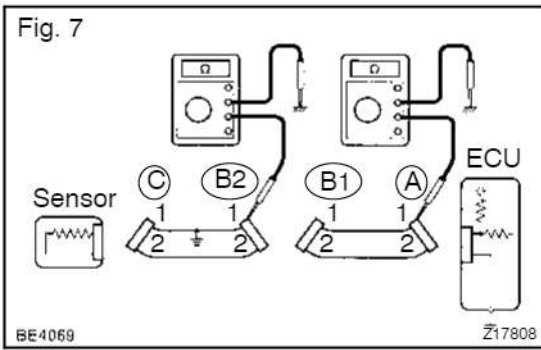

- (2) Disconnect connector "B" and measure the resistance between terminal 1 of connector "A" and body ground, and terminal 1 of connector "B2" and body ground.

In the case of Fig. 7:

Between terminal 1 of connector "A" and body ground → No continuity

Between terminal 1 of connector "B2" and body ground → Continuity (short)

Therefore, it is found out that there is a short circuit between terminal 1 of connector "B2" and terminal 1 of connector "C".

8. CHECK AND REPLACE ECU

First check the ECU ground circuit. If it is faulty, repair it. If it is normal, the ECU could be faulty, so replace the ECU with a normal functioning one and check that the symptoms appear.

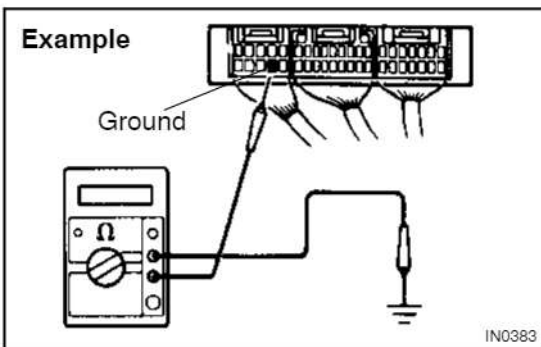

- (1) Measure the resistance between the ECU ground terminal and the body ground.

Resistance: 1 Ω or less

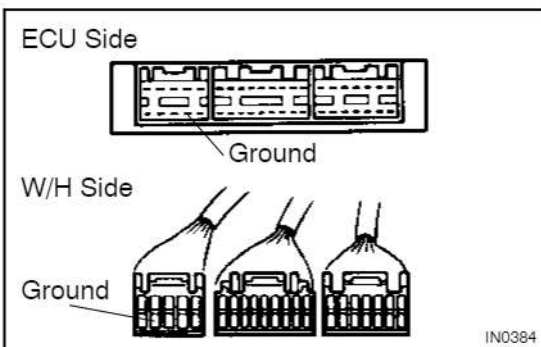

- (2) Disconnect the ECU connector, check the ground terminals on the ECU side and the wire harness side for bend and check the contact pressure.

TERMS**ABBREVIATIONS USED IN THIS MANUAL**

IN012-16

Abbreviations	Meaning
ABS	Anti-Lock Brake System
A/C	Air Conditioner
AC	Alternating Current
ACC	Accessory
ACIS	Acoustic Control Induction System
ACSD	Automatic Cold Start Device
A.D.D.	Automatic Disconnecting Differential
AHC	Active Height Control Suspension
ALR	Automatic Locking Retractor
ALT	Alternator
AMP	Amplifier
ANT	Antenna
APPROX.	Approximately
A/T	Automatic Transmission (Transaxle)
ATF	Automatic Transmission Fluid
AUTO	Automatic
BA	Brake Assist
BACS	Boost Altitude Compensation System
BAT	Battery
B/L	Bi-Level
BVSV	Bimetallic Vacuum Switching Valve
CB	Circuit Breaker
CD	Compact Disc
CH	Channel
CKD	Complete Knock Down
COMB.	Combination
CPE	Coupe
CRS	Child Restraint System
CTR	Center
DC	Direct Current
DIFF.	Differential
DIFF. LOCK	Differential Lock
DLC	Data Link Connector
DSP	Digital Signal Processor
DTC	Diagnostic Trouble Code
EBD	Electronic Brake Force Distribution
ECT	Electronic Control Transmission
ECU	Electronic Control Unit
EDU	Electronic Driving Unit
EFI	Electronic Fuel Injection
E/G	Engine
ELR	Emergency Locking Retractor

INTRODUCTION - TERMS

FF	Front-Engine Front-Wheel-Drive
FIPG	Formed In Place Gasket
FL	Fusible Link
Fr	Front
FR	Front-Engine Rear-Wheel-Drive
FWD	Front-Wheel-Drive
GND	Ground
H/B	Hatchback
HI	High
HID	High Intensity Discharge (Head Lamp)
HT	Hard Top
HWS	Heated Windshield System
IAC	Idle Air Control
IFS	Independent Front Suspension
IG	Ignition
INT	Intermittent
I/P	Instrument Panel
IRS	Independent Rear Suspension
J/B	Junction Block
J/C	Junction Connector
LAN	Local Area Network
LB	Liftback
LCD	Liquid Crystal Display
LED	Light Emitting Diode
LH	Left-Hand
LHD	Left-Hand Drive
LO	Low
LSD	Limited Slip Differential
LSP & PV	Load Sensing Proportioning And Bypass Valve
LSPV	Load Sensing Proportioning Valve
MAP	Manifold Absolute Pressure
MAX.	Maximum
MIC	Microphone
MIL	Malfunction Indicator Lamp
MIN.	Minimum
MP	Multipurpose
MPI	Multipoint Electronic Fuel Injection
MPX	Multiplex Communication System
M/T	Manual Transmission
N	Neutral
No.	Number
O2S	Oxygen Sensor
O/D	Overdrive
OPT	Option
P & BV	Proportioning And Bypass Valve
PCS	Power Control System

PKB	Parking Brake
PPS	Progressive Power Steering
PS	Power Steering
PTO	Power Take-Off
RAM	Random Access Memory
R/B	Relay Block
RBS	Recirculating Ball Type Steering
R/F	Reinforcement
RFS	Rigid Front Suspension
RH	Right-Hand
RHD	Right-Hand Drive
RLY	Relay
ROM	Read Only Memory
Rr	Rear
RR	Rear-Engine Rear-Wheel Drive
RRS	Rigid Rear Suspension
RWD	Rear-Wheel Drive
SDN	Sedan
SEN	Sensor
SICS	Starting Injection Control System
SPEC	Specification
SRS	Supplemental Restraint System
SSM	Special Service Materials
SST	Special Service Tools
STD	Standard
SW	Switch
SYS	System
T/A	Transaxle
TACH	Tachometer
TDC	Top Dead Center
TEMP.	Temperature
TEMS	TOYOTA Electronic Modulated Suspension
TFT	Toyota Free-Tronic
T/M	Transmission
TMC	TOYOTA Motor Corporation
TRC	Traction Control System
U/D	Underdrive
VENT	Ventilator
VIN	Vehicle Identification Number
VSC	Vehicle Stability Control
w/	With
WGN	Wagon
W/H	Wire Harness
w/o	Without
1st	First
2nd	Second











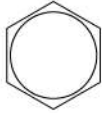

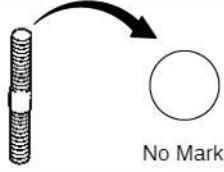
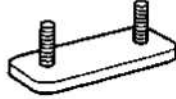



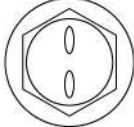
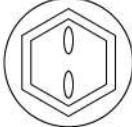







INTRODUCTION - TERMS

2WD	Two Wheel Drive Vehicle (4x2)
4WD	Four Wheel Drive Vehicle (4x4)

STANDARD BOLT

HOW TO DETERMINE BOLT STRENGTH

SS028-01

Bolt Type				Class
Hexagon Head Bolt		Stud Bolt	Weld Bolt	
Normal Recess Bolt	Deep Recess Bolt			
  No Mark	 No Mark	 No Mark		4T
 				5T
  w/ Washer	 w/ Washer			6T
 	 			7T
		 		8T
				9T
	 			10T
	 			11T

cardiagn.com











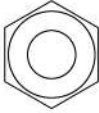
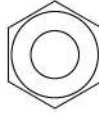
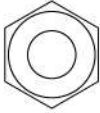



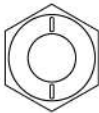

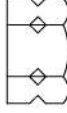

B06431

SPECIFIED TORQUE FOR STANDARD BOLTS

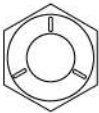
Class	Diameter mm	Pitch mm	Specified torque					
			Hexagon head bolt			Hexagon flange bolt		
			N·m	kgf·cm	ft·lbf	N·m	kgf·cm	ft·lbf
4T	6	1	5	55	48 in.·lbf	6	60	52 in.·lbf
	8	1.25	12.5	130	9	14	145	10
	10	1.25	26	260	19	29	290	21
	12	1.25	47	480	35	53	540	39
	14	1.5	74	760	55	84	850	61
	16	1.5	115	1,150	83	–	–	–
5T	6	1	6.5	65	56 in.·lbf	7.5	75	65 in.·lbf
	8	1.25	15.5	160	12	17.5	175	13
	10	1.25	32	330	24	36	360	26
	12	1.25	59	600	43	65	670	48
	14	1.5	91	930	67	100	1,050	76
	16	1.5	140	1,400	101	–	–	–
6T	6	1	8	80	69 in.·lbf	9	90	78 in.·lbf
	8	1.25	19	195	14	21	210	15
	10	1.25	39	400	29	44	440	32
	12	1.25	71	730	53	80	810	59
	14	1.5	110	1,100	80	125	1,250	90
	16	1.5	170	1,750	127	–	–	–
7T	6	1	10.5	110	8	12	120	9
	8	1.25	25	260	19	28	290	21
	10	1.25	52	530	38	58	590	43
	12	1.25	95	970	70	105	1,050	76
	14	1.5	145	1,500	108	165	1,700	123
	16	1.5	230	2,300	166	–	–	–
8T	8	1.25	29	300	22	33	330	24
	10	1.25	61	620	45	68	690	50
	12	1.25	110	1,100	80	120	1,250	90
9T	8	1.25	34	340	25	37	380	27
	10	1.25	70	710	51	78	790	57
	12	1.25	125	1,300	94	140	1,450	105
10T	8	1.25	38	390	28	42	430	31
	10	1.25	78	800	58	88	890	64
	12	1.25	140	1,450	105	155	1,600	116
11T	8	1.25	42	430	31	47	480	35
	10	1.25	87	890	64	97	990	72
	12	1.25	155	1,600	116	175	1,800	130

cardiagn.com

HOW TO DETERMINE NUT STRENGTH

Present Standard Hexagon Nut	Nut Type		Class
	Old Standard Hexagon Nut		
	Cold Forging Nut	Cutting Processed Nut	
 No Mark			4N
 No Mark (w/ Washer)	 No Mark (w/ Washer)	 No Mark	5N (4T)
  			6N
	 	  *	7N (5T)
 			8N
 	 	 No Mark	10N (7T)
 			11N
 			12N

*: Nut with 1 or more marks on one side surface of the nut.

HINT:

Use the nut with the same number of the nut strength classification or the greater than the bolt strength classification number when tightening parts with a bolt and nut.

Example: Bolt = 4T

Nut = 4N or more

LAND CRUISER (W/G) SUP (RM731E)

SUSPENSION AND AXLE

SS00J-09

SERVICE DATA

Front differential	Companion flange vertical runout	Max.	0.09 mm (0.0035 in.)	
	Companion flange lateral runout	Max.	0.09 mm (0.0035 in.)	
	Drive pinion preload (at starting)	New bearing	1.0 – 1.6 N·m (10 – 16 kgf·cm, 8.7 – 13.9 in.·lbf)	
		Reused bearing	0.5 – 0.8 N·m (5 – 8 kgf·cm, 4.3 – 6.9 in.·lbf)	
	Total preload (at starting)	Drive pinion preload plus 0.4 – 0.6 N·m (4 – 6 kgf·cm, 3.5 – 5.2 in.·lbf)		
	Ring gear runout	0.07 mm (0.0028 in.)		
	Ring gear backlash	0.13 – 0.18 mm (0.0051 – 0.0071 in.)		
	Side gear backlash	0.05 – 0.20 mm (0.0020 – 0.0079 in.)		
Side gear thrust washer thickness	0.9 mm (0.035 in.) 1.0 mm (0.039 in.) 1.1 mm (0.043 in.) 1.2 mm (0.047 in.) 1.3 mm (0.051 in.)			

SERVICE SPECIFICATIONS - SUSPENSION AND AXLE

<p>Front differential</p>	<p>Side bearing adjusting washer thickness</p>	<p>2.58 mm (0.1016 in.) 2.60 mm (0.1024 in.) 2.62 mm (0.1031 in.) 2.64 mm (0.1039 in.) 2.66 mm (0.1047 in.) 2.68 mm (0.1055 in.) 2.70 mm (0.1063 in.) 2.72 mm (0.1071 in.) 2.74 mm (0.1079 in.) 2.76 mm (0.1087 in.) 2.78 mm (0.1094 in.) 2.80 mm (0.1102 in.) 2.82 mm (0.1110 in.) 2.84 mm (0.1118 in.) 2.86 mm (0.1126 in.) 2.88 mm (0.1134 in.) 2.90 mm (0.1142 in.) 2.92 mm (0.1150 in.) 2.94 mm (0.1157 in.) 2.96 mm (0.1165 in.) 2.98 mm (0.1173 in.) 3.00 mm (0.1181 in.) 3.02 mm (0.1189 in.) 3.04 mm (0.1197 in.) 3.06 mm (0.1205 in.) 3.08 mm (0.1213 in.) 3.10 mm (0.1220 in.) 3.12 mm (0.1228 in.) 3.14 mm (0.1236 in.) 3.16 mm (0.1244 in.) 3.18 mm (0.1252 in.) 3.20 mm (0.1260 in.) 3.22 mm (0.1268 in.) 3.24 mm (0.1276 in.) 3.26 mm (0.1283 in.) 3.28 mm (0.1291 in.) 3.30 mm (0.1299 in.) 3.32 mm (0.1307 in.) 3.34 mm (0.1315 in.) 3.36 mm (0.1323 in.) 3.38 mm (0.1331 in.) 3.40 mm (0.1339 in.) 3.42 mm (0.1346 in.) 3.44 mm (0.1354 in.) 3.46 mm (0.1362 in.) 3.48 mm (0.1370 in.)</p>
---------------------------	--	---



cardiagn.com

Front differential	Drive pinion bearing adjusting washer thickness	1.70 mm (0.0669 in.) 1.73 mm (0.0681 in.) 1.76 mm (0.0693 in.) 1.79 mm (0.0704 in.) 1.82 mm (0.0717 in.) 1.85 mm (0.0729 in.) 1.88 mm (0.0740 in.) 1.91 mm (0.0752 in.) 1.94 mm (0.0764 in.) 1.97 mm (0.0776 in.) 2.00 mm (0.0787 in.) 2.03 mm (0.0799 in.) 2.06 mm (0.0811 in.) 2.09 mm (0.0822 in.) 2.12 mm (0.0835 in.) 2.15 mm (0.0847 in.) 2.18 mm (0.0858 in.) 2.21 mm (0.0870 in.) 2.24 mm (0.0882 in.) 2.27 mm (0.0894 in.) 2.30 mm (0.0906 in.) 2.33 mm (0.0918 in.)
--------------------	---	--

TORQUE SPECIFICATION

FRONT DIFFERENTIAL CARRIER (IFS)			
Filler plug	49	500	36
Drain plug	49	500	36
Bearing cap x Differential carrier	85	870	63
Oil deflector x Differential carrier cover	7.3	74	64 in.·lbf
Differential carrier cover x Differential carrier	47	475	34
Differential case x Ring gear	97	985	71
Companion flange x Drive pinion	See page SA-8		



BRAKE**SERVICE DATA**

SS062-11

Brake pedal height (from asphalt sheet)	w/ ABS LHD	183.7 – 193.7 mm (7.232 – 7.626 in.)
	w/ ABS RHD	190.2 – 200.2 mm (7.488 – 7.882 in.)
Brake pedal free play		1.0 – 6.0 mm (0.039 – 0.236 in.)
Brake pedal reserve distance at 490 N (50 kgf, 110.1 lbf)	LHD	More than 116 mm (4.57 in.)
	RHD	More than 121 mm (4.76 in.)

TORQUE SPECIFICATION

Part tightened	N·m	kgf·cm	ft·lbf
Brake line union nut	15	155	11
Hydraulic brake booster clevis lock nut	25	260	19
Hydraulic brake booster x Pedal bracket	15	155	11
Bleeder plug	11	110	8
Reservoir set screw	1.7	17.5	15.2 in.·lbf
Master cylinder pressure sensor	81	830	60
Accumulator x Booster pump motor	54	550	36
ABS ECU or ABS & BA & TRC & VSC ECU set nut	5.0	51	44 in.·lbf



BODY

SS00L-05











TORQUE SPECIFICATION

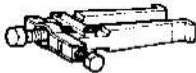
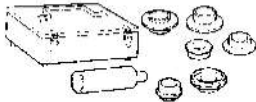



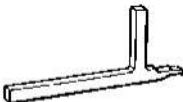

Part tightened	N·m	kgf·cm	ft·lbf
FRONT WIPER AND WASHER	-	-	-
Wiper arm x Wiper link	20	204	15
Wiper link x Body	5.4	55	48 in.·lbf

SUSPENSION AND AXLE

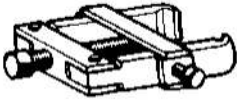
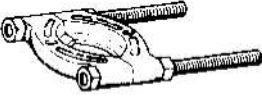
SST (Special Service Tools)



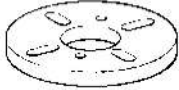

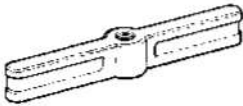
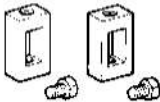
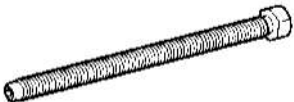

PP20H-01

	09223-15020	Oil Seal & Bearing Replacer	Front differential (RFS) Rear axle (RFS)
	09308-00010	Oil Seal Puller	Front axle (RFS) Front differential (IFS) Rear axle Rear differential
	09308-10010	Oil Seal Puller	Front and rear differential
	09316-60011	Transmission & Transfer Bearing Replacer	Front and rear differential
	(09316-00011)	Replacer Pipe	
	09330-00021	Companion Flange Holding Tool	Front and rear differential
	09350-30020	TOYOTA Automatic Transmission Tool Set	Front differential (IFS)
	(09350-07060)	No.1 Snap Ring Expander	
	09502-12010	Differential Bearing Replacer	Front differential (IFS)
	09504-22011	Differential Side Bearing Replacer	Front differential (IFS) Rear differential (w/ Diff. lock)
	09506-30012	Differential Drive Pinion Rear Bearing Cone Replacer	Front differential
	09506-35010	Differential Drive Pinion Rear Bearing Replacer	Front and rear differential Rear suspension (RFS)

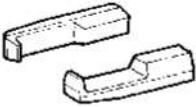
	09550-00032	Replacer	Front differential (IFS)
	09556-22010	Drive Pinion Front Bearing Remover	Front and rear differential
	09950-00020	Bearing Remover	Front drive shaft (IFS) Front and rear differential
	09950-30011	Puller A Set	Front and rear differential
	(09951-03010)	Upper Plate	
	(09953-03010)	Center Bolt	
	(09954-03010)	Arm	
	(09955-03030)	Lower Plate 130	
	(09956-03020)	Adapter 18	
	09950-40011	Puller B Set	Front suspension Front and rear differential
	(09951-04020)	Hanger 200	
	(09952-04010)	Slide Arm	
	(09953-04030)	Center Bolt 200	

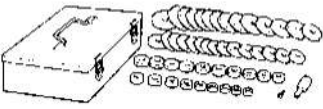
cardiagn.com

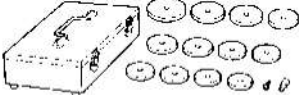
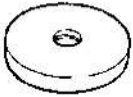
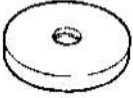
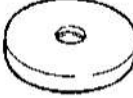
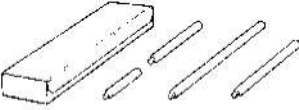
PREPARATION - SUSPENSION AND AXLE

	<p>(09954-04010) Arm 25</p>	
	<p>(09955-04061) Claw No.6</p>	
	<p>(09957-04010) Attachment</p>	
	<p>(09958-04011) Holder</p>	
	<p>09950-60010 Replacer Set</p>	<p>Front suspension (IFS) Front differential (RFS) Rear suspension (RFS) Rear differential AHC pump & motor (IFS)</p>
	<p>(09951-00410) Replacer 41</p>	
	<p>(09951-00480) Replacer 48</p>	
	<p>09950-60020 Replacer Set No.2</p>	<p>Front and rear axle Front differential (IFS) Rear axle Rear differential</p>
	<p>(09951-00710) Replacer 71</p>	
	<p>(09951-00730) Replacer 73</p>	
	<p>(09951-00780) Replacer 78</p>	
	<p>09950-70010 Handle Set</p>	<p>Front and rear axle Front suspension Rear differential AHC pump & motor (IFS)</p>
	<p>(09951-07100) Handle 100</p>	



cardiagn.com

	(09951-07150) Handle 150	
---	--------------------------	--

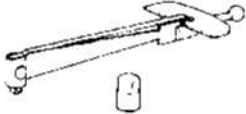
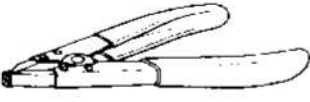

RECOMMENDED TOOLS

	<p>09025-00010 Torque Wrench (30 kgf-cm)</p>	
	<p>09905-00012 Snap Ring No.1 Expander .</p>	

cardiagn.com

EQUIPMENT

Dial indicator with magnetic base	
Micrometer	
Torque wrench	

LUBRICANT







FRONT DIFFERENTIAL		
Item	Capacity	Classification
Hypoid gear oil	1.70 liters (1.80 US qts, 1.50 Imp.qts)	Hypoid gear oil API GL-5 Above -18 °C (0°F) SAE 90 Below -18 °C (0°F) SAE 80W-90 or 80W

SSM (Special Service Materials)

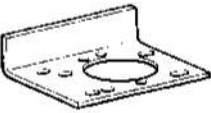

08826-00090 Seal Packing 1281, THREE BOND 1281 or equivalent (FIPG)	
---	--

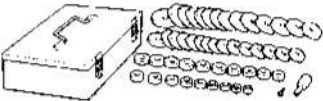
BRAKE**SST (Special Service Tools)**

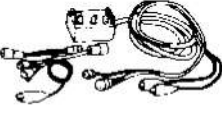
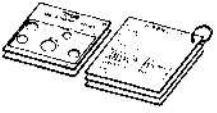
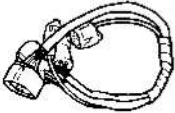
PP2FS-01

	09023-00100	Union Nut Wrench 10 mm	
	09318-12010	Transfer Bearing Adjusting Nut Wrench	
	09630-00014	Power Steering Gear Housing Overhaul Tool Set	
	(09631-00142)	Overhaul Stand	
	09709-29018	LSPV Gauge Set	
	09843-18020	Diagnosis Check Wire	
	09950-60010	Replacer Set	
	(09951-00180)	Replacer 18	
	(09951-00190)	Replacer 19	
	09990-00150	ABS Actuator Checker and Sub-harness	
	09990-00240	ABS Actuator Checker Sheet "G"	
	09990-00480	ABS Actuator Checker Sub-harness "S"	

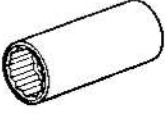
RECOMMENDED TOOLS

	09017-12301 Deep Socket Wrench 30 mm .	
	09082-00040 TOYOTA Electrical Tester.	

EQUIPMENT

PROCJ-08

Torque wrench	
Effort gauge	

LUBRICANT

Item	Capacity	Classification
Brake fluid	-	SAE J1703 or FMVSS No. 116 DOT3

ABS & VEHICLE STABILITY CONTROL (VSC) & BRAKE ASSIST (BA) SYSTEM

HOW TO PROCEED WITH TROUBLESHOOTING

DI8WY-01

Troubleshooting in accordance with the procedure on the following pages.

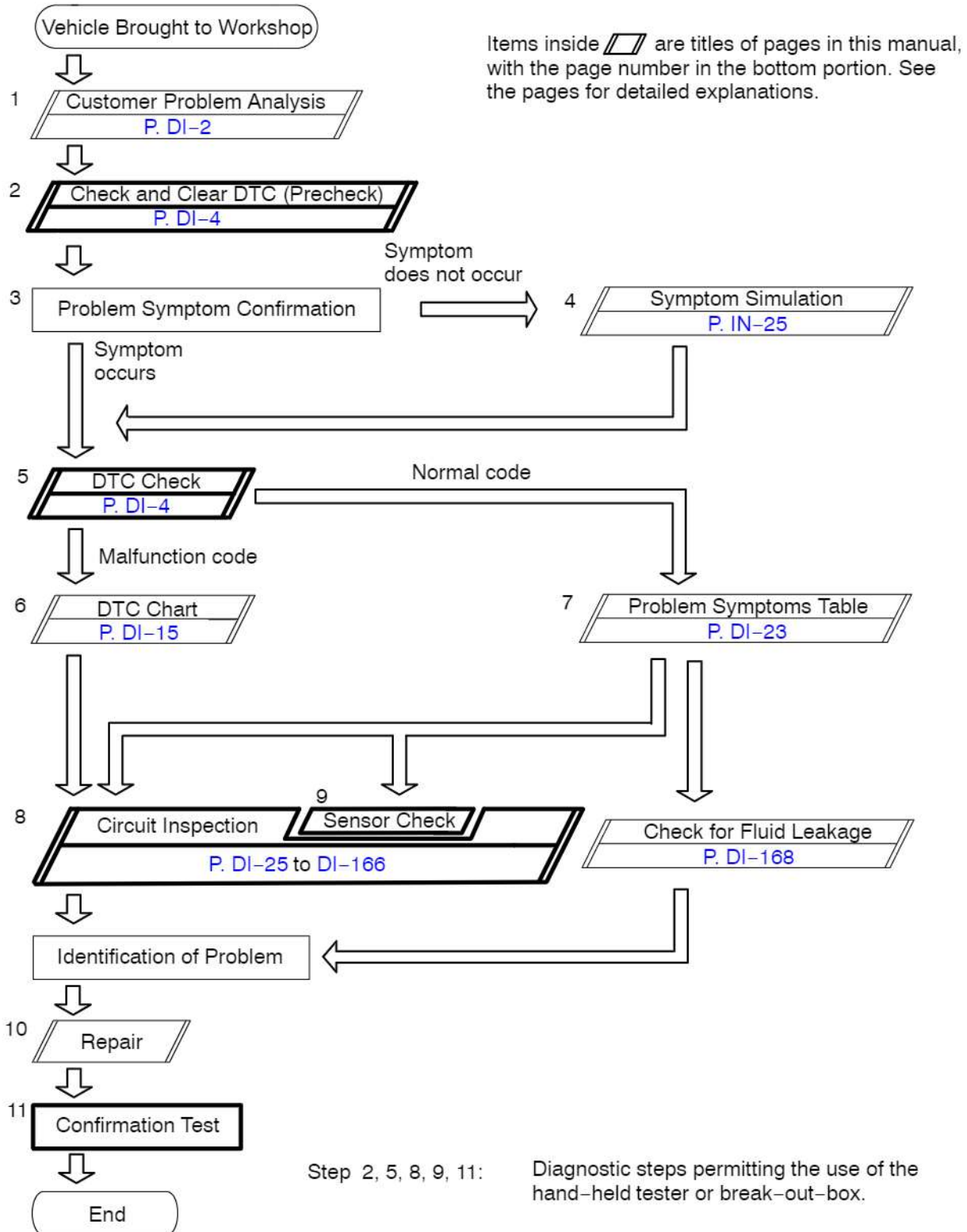

CUSTOMER PROBLEM ANALYSIS CHECK

ABS & BA Check Sheet

Inspector's
Name _____

Customer's Name		Registration No.	
		Registration Year	/ /
		Frame No.	
Date Vehicle Brought In	/ /	Odometer Reading	km miles

Date Problem First Occurred	/ /
Frequency Problem Occurs	<input type="checkbox"/> Continuous <input type="checkbox"/> Intermittent (times a day)

Symptoms	<input type="checkbox"/> ABS does not operate.	
	<input type="checkbox"/> ABS does not operate efficiently.	
	<input type="checkbox"/> BA does not operate.	
	ABS Warning Light Abnormal	<input type="checkbox"/> Remains ON <input type="checkbox"/> Does not Light Up
	BRAKE Warning Light Abnormal (PKB released)	<input type="checkbox"/> Remains ON <input type="checkbox"/> Does not Light Up
Brake Warning Buzzer Abnormal	<input type="checkbox"/> Sounds <input type="checkbox"/> Does not sounds	

DTC Check	1st Time	<input type="checkbox"/> Normal Code <input type="checkbox"/> Malfunction Code (Code)
	2nd Time	<input type="checkbox"/> Normal Code <input type="checkbox"/> Malfunction Code (Code)

TRC & VSC Check Sheet

Inspector's Name _____

Customer's Name		Registration No.	
		Registration Year	/ /
		Frame No.	
Date Vehicle Brought In	/ /	Odometer Reading	km miles

Date Problem First Occurred	/ /
Frequency Problem Occurs	<input type="checkbox"/> Continuous <input type="checkbox"/> Intermittent (times a day)

Symptoms	<input type="checkbox"/> TRC does not operate. (Wheels spin when starting rapidly.)	
	<input type="checkbox"/> VSC does not operate. (Wheels sideslip at the time of sharp turning.)	
	VSC OFF Indicator Light Abnormal	<input type="checkbox"/> Remains ON <input type="checkbox"/> Does not Light Up
	VSC TRC Warning Light Abnormal	<input type="checkbox"/> Remains ON <input type="checkbox"/> Does not Light Up
	SLIP Indicator Light Abnormal	<input type="checkbox"/> Remains ON <input type="checkbox"/> Does not Light Up
	ACTIVE TRC Indicator Light Abnormal	<input type="checkbox"/> Remains ON <input type="checkbox"/> Does not Light Up

Check Item	ABS Warning Light	<input type="checkbox"/> Normal <input type="checkbox"/> Malfunction Code (Code)
	Malfunction Indicator Lamp	<input type="checkbox"/> Normal <input type="checkbox"/> Malfunction Code (Code)
	BRAKE Warning Light Abnormal	<input type="checkbox"/> Remains ON <input type="checkbox"/> Does not Light Up
	Brake Warning Buzzer Abnormal	<input type="checkbox"/> Sounds <input type="checkbox"/> Does not Sounds

DTC Check	1st Time	<input type="checkbox"/> Normal Code <input type="checkbox"/> Malfunction Code (Code)
	2nd Time	<input type="checkbox"/> Normal Code <input type="checkbox"/> Malfunction Code (Code)

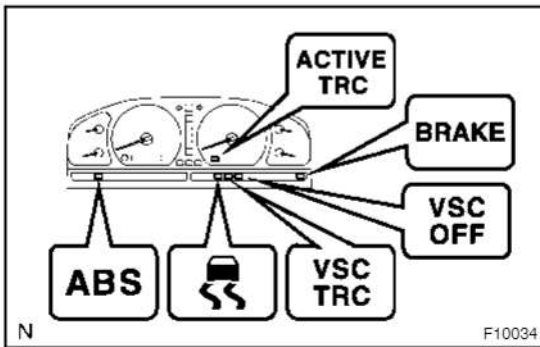

PRE-CHECK

1. DIAGNOSIS SYSTEM

- (a) Check the warning lights and buzzer.
 - (1) Release parking brake lever.
 - (2) When the ignition switch is turned ON, check that the ABS, VSC TRC and BRAKE warning lights, VSC OFF, SLIP and ACTIVE TRC indicator lights goes on for 3 sec.
 - (3) When depressing the brake pedal repeatedly it may turn on the warning lights and buzzer.

HINT:

- If the ECU stores DTC, VSC TRC warning light and VSC OFF indicator light is ON.
- If the indicator check result is not normal, proceed to troubleshooting for the ABS warning light circuit, VSC TRC warning light circuit, BRAKE warning light circuit, VSC OFF indicator light circuit, SLIP indicator light circuit and ACTIVE TRC indicator light circuit.

Trouble Area	See Page
ABS warning light circuit	DI-133
VSC TRC warning light circuit	DI-138
BRAKE warning light circuit	DI-144
VSC OFF indicator light circuit	DI-156
SLIP indicator light circuit	DI-149
ACTIVE TRC indicator light circuit	DI-153

- (b) In case of not using hand-held tester:
Check the DTC.

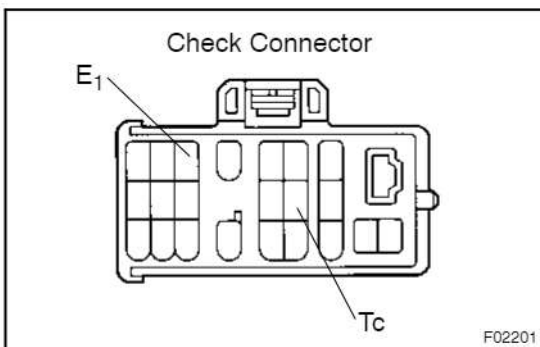

- (1) Using SST, connect terminals Tc and E₁ of check connector.
SST 09843-18020
- (2) Turn the ignition switch ON.
- (3) Read the DTC from the ABS or VSC TRC warning light on the combination meter.

HINT:

- If no code appears, inspect the Tc circuit, ABS or VSC TRC warning light circuit.

Trouble Area	See page
Tc circuit	DI-164
ABS warning light circuit	DI-133
VSC TRC warning light circuit	DI-138

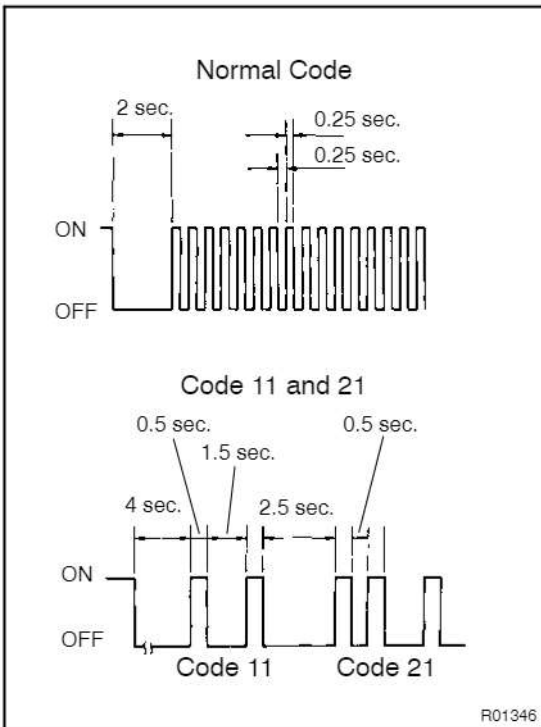

- As an example, the blinking patterns for normal code and codes 11 and 21 are shown on the left.
 - Codes are explained in the code table on [page DI-15](#).
 - After completing the check, disconnect terminals Tc and E₁ of check connector and turn off the display.
- If 2 or more malfunctions are indicated at the same time the lowest numbered DTC will be displayed 1st.

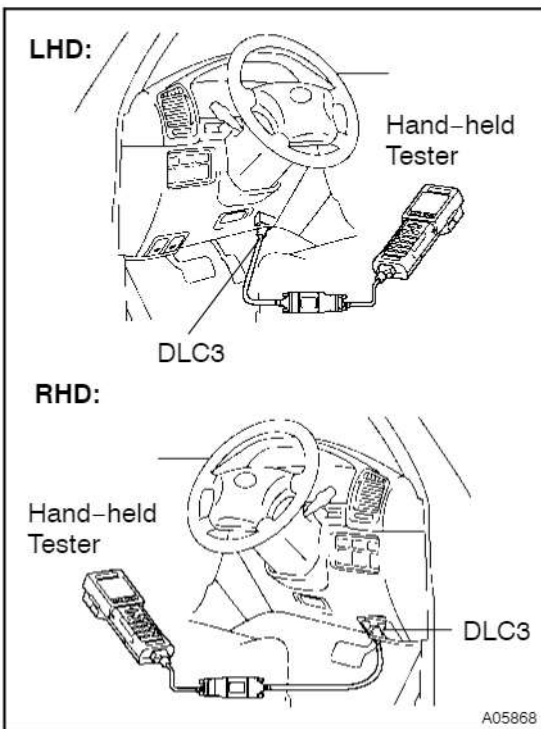

- (c) In case of using hand-held tester:
Check the DTC.
- Hook up the hand-held tester to the DLC3.
 - Turn the ignition switch ON.
 - Read the DTC by following the prompts on the tester screen.

HINT:

Please refer to the hand-held tester operator's manual for further details.

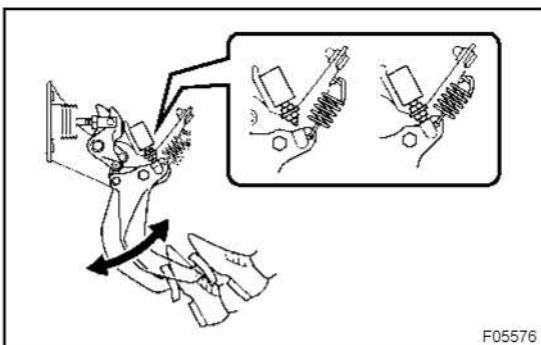

- (d) In case of not using hand-held tester:
Clear the DTC.
- Using SST, connect terminals Tc and E₁ of check connector.
- SST 09843-18020
- Turn the ignition switch ON.
 - Clear the DTC stored in ECU by depressing the brake pedal 8 or more times within 5 sec.

- (4) Check that the warning light shows the normal code.
- (5) Remove the SST from the terminals of check connector.

SST 09843-18020

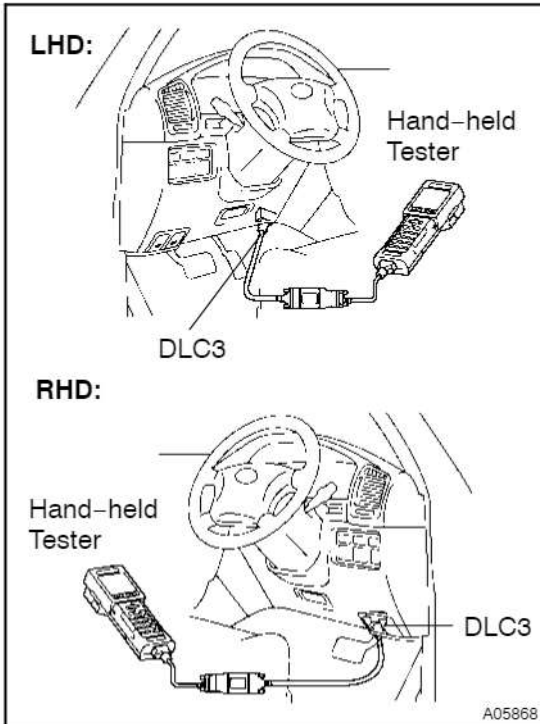

- (e) In case of using hand-held tester:
Clear the DTC.
- (1) Hook up the hand-held tester to the DLC3.
 - (2) Turn the ignition switch ON.
 - (3) Operate the hand-held tester to erase the codes.
(See hand-held tester operator's manual.)

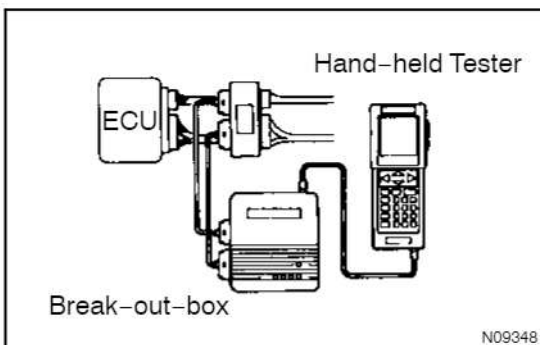

- (f) Reference:
Using break-out-box and hand-held tester, measure the ECU terminal values.
- (1) Turn the ignition switch OFF.
 - (2) Hook up the break-out-box and hand-held tester to the vehicle.
 - (3) Turn the ignition switch ON.
 - (4) Read the ECU input/output values by following the prompts on the tester screen.

HINT:

- Hand-held tester has a "Snapshot" function. This records the measured values and is effective in the diagnosis of intermittent problems.
- Please refer to the hand-held tester/break-out-box operator's manual for further details.

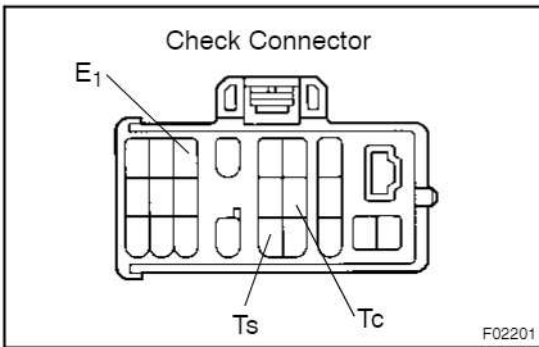

2. SPEED SENSOR SIGNAL CHECK (TEST MODE)

HINT:

If the ignition switch is turned from ON to ACC or LOCK during test mode, DTC will be erased.

- (a) In case of not using hand-held tester:
Check the speed sensor signal.
- (1) Turn the ignition switch OFF.
 - (2) Using SST, connect terminals Ts and E₁ of check connector.
- SST 09843-18020
- (3) Start the engine.

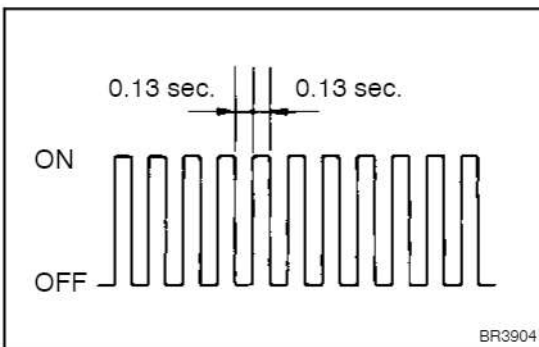

- (4) Check that the ABS warning light blinks.

HINT:

If the ABS warning light does not blink, inspect the ABS warning light circuit and Ts circuit (See page DI-133 and DI-166).

- (5) Keep the vehicle in the stationary condition on the flat place for 6 sec. or more.
- (6) Shift the transfer lever in L4 position and turn the center diff. lock switch ON.
- (7) Leaving the vehicle in the stationary condition and the brake pedal in free condition for 1 sec. or more, continue to depress the brake pedal with 98 N (10 kgf, 22 lbf) of force or more for 1 sec. or more.
- (8) Leaving the vehicle in the stationary condition, depress the brake pedal with 980 N (100 kgf, 221 lbf) of force or more quickly.

HINT:

At this time, the ABS warning light comes on for 3 sec.

- (9) Drive vehicle straight forward.
When driving the vehicle with the speed faster than 45 km/h (28 mph) for several seconds, check that the ABS warning light comes off.

HINT:

There is a case that the sensor check is not completed if the vehicle has its rear wheels spun or its steering wheel steered during this check.

- (10) Stop the vehicle.
 - (11) Using SST, connect terminals Tc and E₁ of check connector.
- SST 09843-18020
- (12) Read the number of blinks of the ABS warning light.

HINT:

- See the list of DTC shown on the next page.
 - If every sensor is normal, a normal code is output (A cycle of 0.25 sec. ON and 0.25 sec. OFF is repeated).
 - If 2 or more malfunctions are indicated at the same time, the lowest numbered code will be displayed 1st.
- (13) After doing the check, disconnect the SST from terminals Ts and E₁, Tc and E₁ of check connector and turn ignition switch OFF.

SST 09843-18020

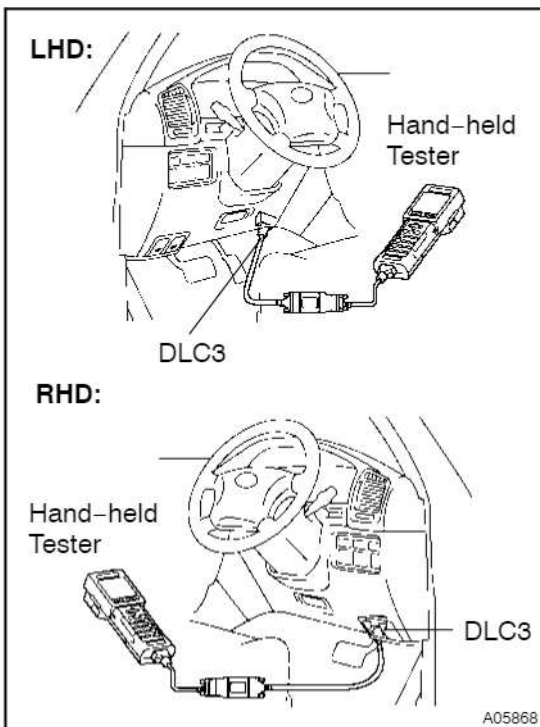
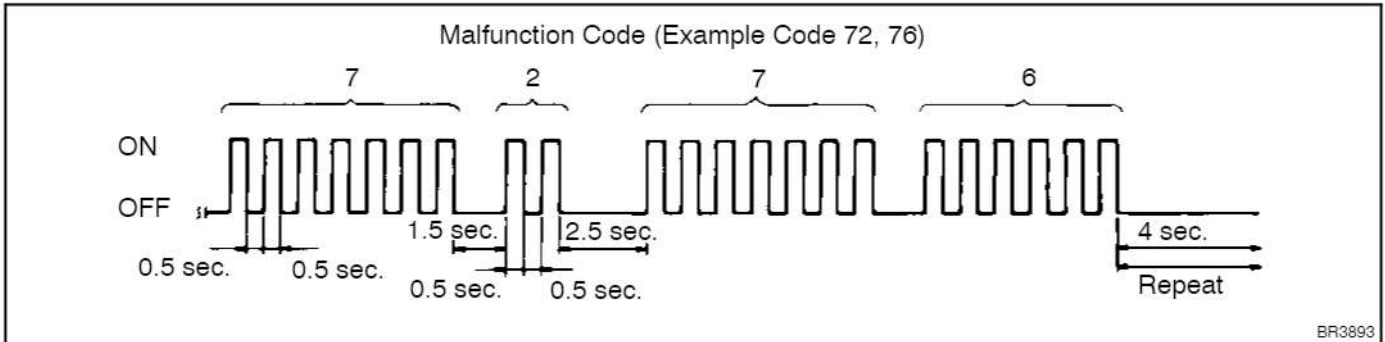

(b) In case of using hand-held tester:

Check the sensor signal.

- (1) Hook up the hand-held tester to the DLC3.
- (2) Do step (3) and (4) to (10) on the previous page.
- (3) Read the DTC by following the prompts on the tester screen.

HINT:

Please refer to the hand-held tester operator's manual for further details.

DTC of speed sensor check function:

Code No.	Diagnosis	Trouble Area
C1271 / 71	Low output voltage of right front speed sensor	<ul style="list-style-type: none"> • Right front speed sensor • Sensor installation • Sensor rotor
C1272 / 72	Low output voltage of left front speed sensor	<ul style="list-style-type: none"> • Left front speed sensor • Sensor installation • Sensor rotor
C1273 / 73	Low output voltage of right rear speed sensor	<ul style="list-style-type: none"> • Right rear speed sensor • Sensor installation • Sensor rotor
C1274 / 74	Low output voltage of left rear speed sensor	<ul style="list-style-type: none"> • Left rear speed sensor • Sensor installation • Sensor rotor
C1275 / 75	Abnormal change in output voltage of right front speed sensor	Right front speed sensor rotor
C1276 / 76	Abnormal change in output voltage of left front speed sensor	Left front speed sensor rotor
C1277 / 77	Abnormal change in output voltage of right rear speed sensor	Right rear speed sensor rotor
C1278 / 78	Abnormal change in output voltage of left rear speed sensor	Left rear speed sensor rotor
C1279 / 79	Deceleration sensor is faulty	<ul style="list-style-type: none"> • Deceleration sensor • Sensor installation
C1281 / 81	Master cylinder pressure sensor output signal is faulty	Master cylinder pressure sensor
C1282 / 82	Transfer indicator (center diff. lock) switch malfunction	Transfer indicator (center diff. lock) switch
C1283 / 83	Transfer L4 position switch malfunction	Transfer L4 position switch

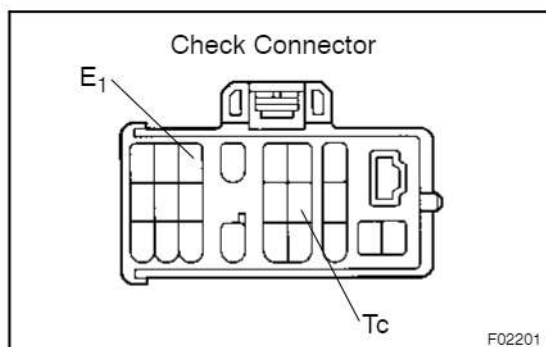

**3. In case of not using hand-held tester:
VSC SENSOR CHECK (TEST MODE)**

HINT:

If the ignition switch is turned from ON to ACC or LOCK during test mode, DTC will be erased.

(a) Procedures for test mode:

- (1) Turn the ignition switch OFF.
- (2) Check that the shift lever position is at P range, turn the steering wheel to the neutral range.
- (3) Using SST, connect terminals Ts and E₁ of check connector.

SST 09843-18020

- (4) Start the engine.

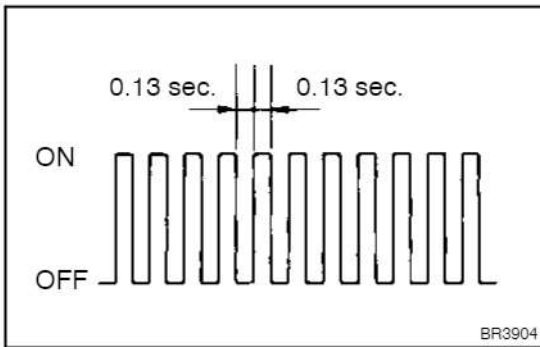

- (5) Check that the VSC TRC warning light blinks.

HINT:

If the VSC TRC warning light does not blink, inspect the VSC TRC warning light circuit and Ts terminal circuit (See page DI-138 and DI-166).

- (b) When replacing yaw rate sensor and/or ECU, the first time only:

Perform the yaw rate sensor zero point calibration.

HINT:

Before the yaw rate sensor zero point calibration, shift the shift lever to P range, turn the ignition switch ON, and repeat connecting and disconnecting between terminals Ts and E₁ of check connector 4 times or more for 8 sec. After this, leave the vehicle in stationary condition for 15 sec. and carry out the yaw rate sensor zero point calibration.

Place the vehicle on the horizontal surface and carry out the zero point calibration of the yaw rate sensor by turning the ignition switch ON.

HINT:

After turning the ignition switch ON, keep the vehicle stationary condition until the VSC TRC warning changes from lighting to light-out.

- (c) When replacing deceleration sensor and/or ECU, the first time only:

Perform the deceleration sensor zero point calibration.

HINT:

Before the deceleration sensor zero point calibration, shift the shift lever to P range, turn the ignition switch ON, and repeat connecting and disconnecting between terminals Ts and E₁ of check connector 4 times or more for 8 sec. Then, short circuit the check connector between Ts and E₁ again and turn the ignition switch ON. After this, leave the vehicle in stationary condition for 15 sec. and carry out the deceleration sensor zero point calibration.

Place the vehicle on the horizontal surface and carry out the zero point calibration of the deceleration sensor by turning the ignition switch ON.

HINT:

After turning the ignition switch ON, keep the vehicle stationary condition until the VSC TRC warning changes from lighting to blinking in about 2 seconds.

NOTICE:

Do not turn OFF the ignition switch within 2 seconds after VSC TRC warning starts blinking.

- (d) Check the steering angle sensor.

Turn the steering wheel either to left or right for 450° or more from the vehicle stationary condition, and turn back the steering wheel to the straight ahead position.

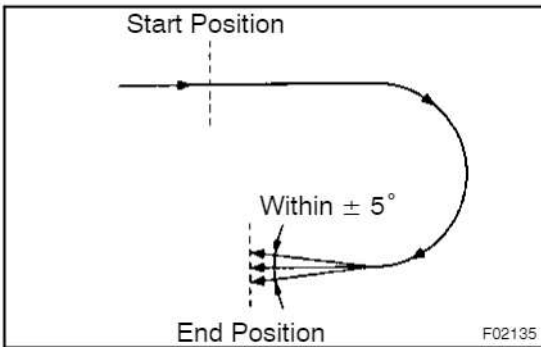

- (e) Check the yaw rate sensor.
Shift the shift lever to the D range and drive the vehicle at the vehicle speed of approx. 5 km/h (3 mph), turn the steering wheel either to left or right for 90° or more, and maintain 180° circular drive for the vehicle.

Stop the vehicle and shift the shift lever to the P range, check that the VSC buzzer sounds for 3 sec.

If the VSC buzzer sounded, the sensor check is in normal completion.

If the VSC buzzer does not sound, do the sensor check again. If the VSC buzzer still won't sound, there is malfunction in the VSC sensor, so check the DTC.

HINT:

- Drive the vehicle circularly by 180°. At the end of the turn, the direction of the vehicle should be within 180° ± 5° of its start position.
- Do not spin the rear wheels.
- Do not shift the shift lever to P range during the turn.
- Do not stop the vehicle during the turn.

- (f) Read the DTC.

(1) Using SST, connect terminals Tc and E₁ of check connector.

SST 09843-18020

(2) Read the number of blinks of the VSC TRC warning light.

HINT:

- See the list of DTC shown on the next page.
- If every sensor is normal, a normal code is output. (A cycle of 0.25 sec. ON and 0.25 sec. OFF is repeated.)
- If 2 or more malfunctions are indicated at the same time, the lowest numbered code will be displayed 1st.

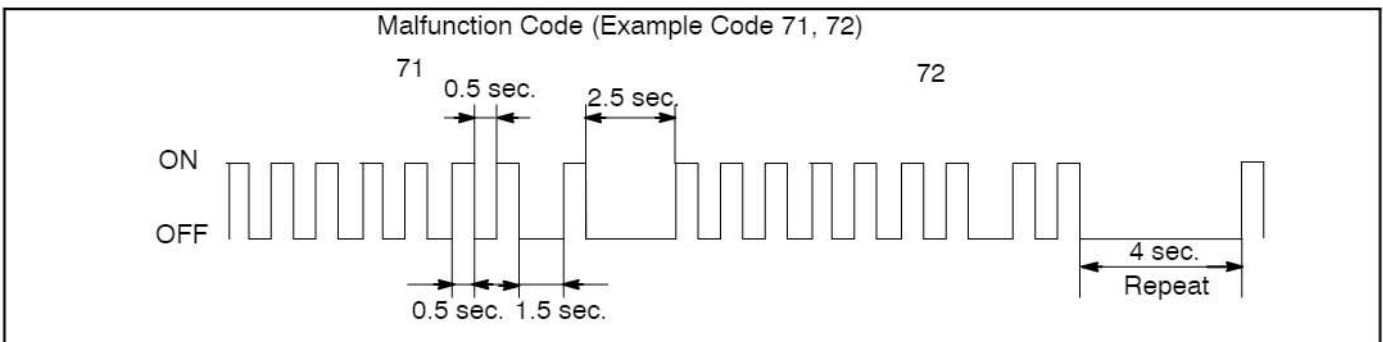

- (3) After doing the check, disconnect the SST from terminals Ts and E₁, Tc and E₁ of check connector and turn ignition switch OFF.

SST 09843-18020

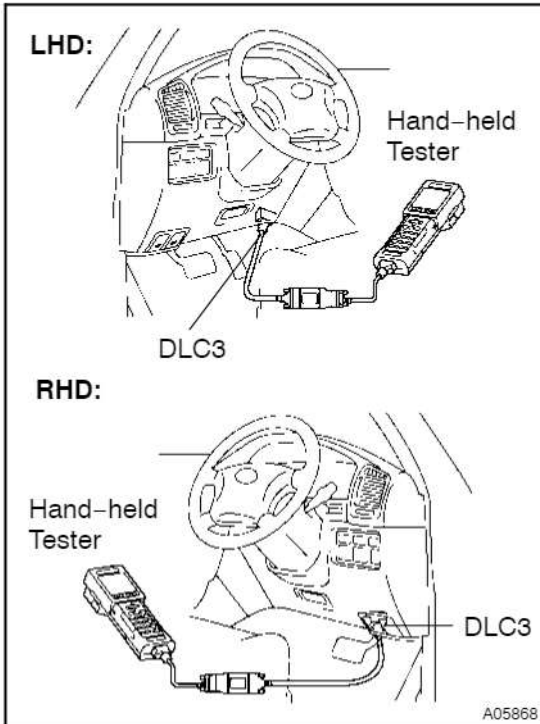

**4. In case of using hand-held tester:
CHECK VSC SENSOR SIGNAL**

- (a) Hook up the hand-held tester to the DLC3.
- (b) Do steps (a) - (2), (a) - (4) and (b) to (e) on the previous pages.
- (c) Read the DTC by following the prompts on the tester screen.

HINT:

Please refer to the hand-held tester operator's manual for further details.

DTC of the VSC sensor check function:

Code No.	Diagnosis	Trouble Area
C0371 / 71	Yaw rate sensor output signal malfunction	<ul style="list-style-type: none"> • Yaw rate sensor • Yaw rate sensor circuit
C1208 / 72	Steering position sensor output signal malfunction	<ul style="list-style-type: none"> • Steering position sensor • Steering position sensor circuit

5. DECELERATION SENSOR OPERATION DIAGNOSIS SYSTEM

CAUTION:

While checking the deceleration sensor operating diagnosis system, ABS does not work and brake system works as a conventional brake system.

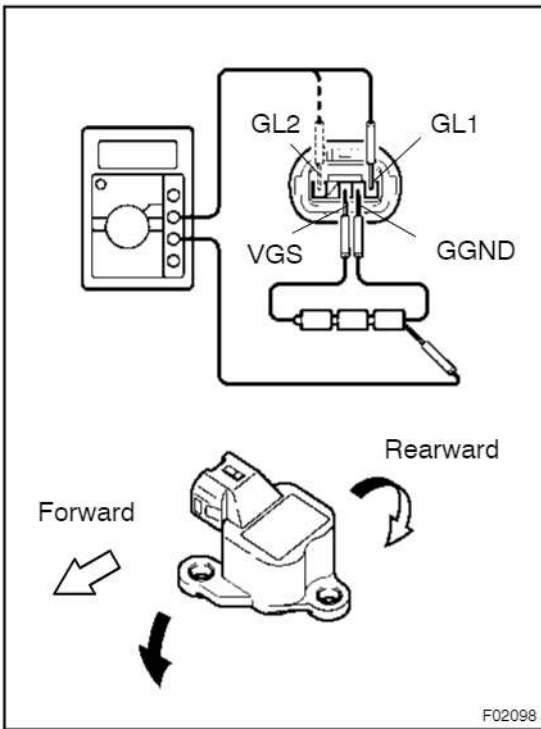

6. DECELERATION SENSOR CHECK

- (a) Connect 3 dry batteries of 1.5 V in series.
- (b) Connect VGS terminal to the batteries' positive (+) terminal, and GGND terminal to the batteries' negative (-) terminal, apply about 4.5 V between VGS and GGND terminals.

NOTICE:

Do not apply voltage of 6 V or more to terminals VGS and GGND.

- (c) Check the output voltage of GL1 and GL2 terminals.

Symbols	Condition	Standard Value
GL1	Horizontal	About 2.3 V
GL1	Lean forward	0.4 V - about 2.3 V
GL1	Lean rearward	About 2.3 V - 4.1 V
GL2	Horizontal	About 2.3 V
GL2	Lean forward	About 2.3 V - 4.1 V
GL2	Lean rearward	0.4 V - about 2.3 V

HINT:

- If the sensor is tilted too much it may show the wrong value.
- If dropped, the sensor should be replaced with a new one.
- The sensor removed from the vehicle should not be placed upside down.

- (d) When replacing the deceleration sensor:

Perform the deceleration sensor zero point calibration.

Shift the shift lever in P range and turn the ignition switch ON, repeat connecting and releasing Ts and E₁ terminals of check connector 4 times or more for 8 sec. After that do not move the vehicle for 15 sec. or more.

HINT:

Before the deceleration sensor zero point calibration, be sure to short circuit the check connector between Ts and E₁ and perform the calibration in test mode.

7. YAW RATE SENSOR ZERO POINT CALIBRATION

HINT:

When replacing the yaw rate sensor or ECU, make sure to perform yaw rate sensor zero point calibration.

- (a) When replacing the ECU:

After replacing ECU, shift the shift lever in P range and turn the ignition switch ON. Do not move the vehicle for 15 sec. or more.

HINT:

At this time, the VSC TRC warning light and VSC OFF indicator light goes on for 15 sec. and goes off. If the VSC TRC warning light and VSC OFF indicator light remains on, carry out yaw rate sensor and deceleration sensor zero point calibration in the test mode.

- (b) When replacing the yaw rate sensor:
Shift the shift lever in P range and turn the ignition switch ON, repeat connecting and releasing Ts and E₁ terminals of check connector 4 times or more for 8 sec. After that do not move the vehicle for 15 sec. or more.

HINT:

When the operation (b) is performed, DTC is deleted.

DIAGNOSTIC TROUBLE CODE CHART

NOTICE:

When removing the part, turn the ignition switch OFF.

HINT:

- Using SST 09843-18020, connect the terminals Tc and E₁ of check connector.
- If any abnormality is not found when inspecting parts, inspect the ECU.
- If a malfunction code is displayed during the DTC check, check the circuit listed that code. For details of each code, turn to the page referred to under the "See page" for respective "DTC No." in the DTC chart.

DTC chart of ABS:

DTC No. (See Page)	Detection Item	Trouble Area
C0278 / 11 (DI-35)	Open or short circuit in ABS solenoid relay circuit	<ul style="list-style-type: none"> • ABS solenoid relay • ABS solenoid relay circuit
C0279 / 12 (DI-35)	B+ short circuit in ABS solenoid relay circuit	
C0226 / 21 (DI-32)	Open or short circuit in hydraulic brake booster solenoid circuit (SFR circuit)	<ul style="list-style-type: none"> • Hydraulic brake booster • SFRR or SFRH circuit
C0236 / 22 (DI-32)	Open or short circuit in hydraulic brake booster solenoid circuit (SFL circuit)	<ul style="list-style-type: none"> • Hydraulic brake booster • SFLR or SFLH circuit
C0246 / 23 (DI-32)	Open or short circuit in hydraulic brake booster solenoid circuit (SRR circuit)	<ul style="list-style-type: none"> • Hydraulic brake booster • SRRR or SRRH circuit
C0256 / 24 (DI-32)	Open or short circuit in hydraulic brake booster solenoid circuit (SRL circuit)	<ul style="list-style-type: none"> • Hydraulic brake booster • SRLR or SRLH circuit
C1225 / 25 (DI-54)	Open or short circuit in hydraulic brake booster solenoid circuit (SA1 circuit)	<ul style="list-style-type: none"> • Hydraulic brake booster • SA1 circuit
C1226 / 26 (DI-54)	Open or short circuit in hydraulic brake booster solenoid circuit (SA2 circuit)	<ul style="list-style-type: none"> • Hydraulic brake booster • SA2 circuit
C1227 / 27 (DI-54)	Open or short circuit in hydraulic brake booster solenoid circuit (SA3 circuit)	<ul style="list-style-type: none"> • Hydraulic brake booster • SA3 circuit
C1228 / 28 (DI-54)	Open or short circuit in hydraulic brake booster solenoid circuit (STR circuit)	<ul style="list-style-type: none"> • Hydraulic brake booster • STR circuit
C0200 / 31*1 (DI-25)	Right front wheel speed sensor signal malfunction	<ul style="list-style-type: none"> • Right front, left front, right rear and left rear speed sensor • Each speed sensor circuit • Sensor rotor
C0205 / 32*1 (DI-25)	Left front wheel speed sensor signal malfunction	
C0210 / 33*1 (DI-25)	Right rear wheel speed sensor signal malfunction	
C0215 / 34*1 (DI-25)	Left rear wheel speed sensor signal malfunction	
C1237 / 37 (DI-66)	Some tire is different size from the other tires	Tire size
C1241 / 41 (DI-67)	Low battery voltage or abnormally high battery voltage	<ul style="list-style-type: none"> • Battery • IC regulator • Power source circuit
C1242 / 42*2 (DI-71)	Open circuit in IG2 circuit	<ul style="list-style-type: none"> • Battery • IC regulator • Power source circuit
C1243 / 43 (DI-75)	Malfunction in deceleration sensor (constant output)	<ul style="list-style-type: none"> • Deceleration sensor • Wire harness for deceleration sensor system

C1244 / 44 (DI-77)	Open or short circuit in deceleration sensor circuit	<ul style="list-style-type: none"> • Deceleration sensor • Deceleration sensor circuit
C1245 / 45 (DI-75)	Malfunction in deceleration sensor	<ul style="list-style-type: none"> • Deceleration sensor • Wire harness for deceleration sensor system
C1246 / 46 (DI-79)	Malfunction in master cylinder pressure sensor	<ul style="list-style-type: none"> • Master cylinder pressure sensor • Master cylinder pressure sensor circuit
C1249 / 49 (DI-82)	Open circuit in stop light switch circuit	Stop light switch circuit
C1251 / 51*2 (DI-87)	Pump motor is locked Open circuit in pump motor ground	Hydraulic brake booster pump motor
C1252 / 52*2 (DI-90)	Hydraulic brake booster pump motor malfunction	<ul style="list-style-type: none"> • Hydraulic brake booster pump motor • Hydraulic brake booster pump motor circuit • Pressure switch (PH or PL)
C1253 / 53*2 (DI-96)	Hydraulic brake booster pump motor relay malfunction	<ul style="list-style-type: none"> • ABS motor 1 or ABS motor 2 relay • ABS motor 1 or ABS motor 2 relay circuit • Hydraulic brake booster pump motor circuit
C1254 / 54*2 (DI-101)	Pressure switch malfunction	<ul style="list-style-type: none"> • Pressure switch (PH or PL) • Pressure switch circuit
C1256 / 56*2 (DI-104)	Accumulator low pressure malfunction	<ul style="list-style-type: none"> • Accumulator • Pressure switch (PH or PL) • Hydraulic brake booster pump motor
C1257 / 57*2 (DI-110)	Power supply drive circuit malfunction	<ul style="list-style-type: none"> • Battery • Power source circuit • ABS & BA & TRC & VSC ECU
C1268 / 68 (DI-114)	Transfer L4 position signal transmission failure	<ul style="list-style-type: none"> • Transfer L4 position switch • Transfer L4 position switch circuit
C1269 / 69 (DI-117)	Malfunction in neutral start switch circuit (R range)	<ul style="list-style-type: none"> • Neutral start switch • Neutral start switch circuit (R range)
Always ON (DI-126)	Malfunction in ABS & BA & TRC & VSC ECU	<ul style="list-style-type: none"> • Battery • IC regulator • Power source circuit • ABS & BA & TRC & VSC ECU

*1: As the DTC cannot be erased by replacing parts alone do either of the following operations.

- (1) Clear DTC ([See page DI-4](#)).
- (2) At the vehicle speed of 20 km/h (12 mph), drive the vehicle for 30 sec. or more.

*2: Using the following table, troubled parts can be specified.

DTC		42		51		52		53		54		56		57	
BRAKE warning light and buzzer		Light	Buzzer	Light	Buzzer	Light	Buzzer	Light	Buzzer	Light	Buzzer	Light	Buzzer	Light	Buzzer
Pressure switch	PH					○	○			○		○	○		
	PL					○	○			○		○	○		
Pump motor circuit	Pump motor			○	○	○	○					○	○		
	MTT wire harness					○	○	○							
	MT+ wire harness			○											
	MT- wire harness			○											
Accumulator malfunction												○	○		
Motor relay circuit	MR1 open circuit							○							
	MR2 open circuit							○							
	MR1 welded contact					○	○	○							
	MR2 welded contact					○	○	○							
Hydraulic brake booster	Pressure leaks					○	○					○	○		
Power source*	IG2 open circuit	○													
ECU	Power supply circuit													○	

*: When IG1 circuit is open, ABS warning light and BRAKE warning light come on.

DTC chart of VSC:

DTC No. (See Page)	Detection Item	Trouble Area
C1231 / 31 (DI-56)	Malfunction in steering angle sensor	<ul style="list-style-type: none"> Steering angle sensor Steering angle sensor circuit
C1232 / 32 (DI-60)	Malfunction in deceleration sensor	<ul style="list-style-type: none"> Deceleration sensor Deceleration sensor circuit
C1233 / 33 (DI-62)	Open or short circuit in yaw rate sensor circuit	<ul style="list-style-type: none"> Yaw rate sensor Yaw rate sensor circuit
C1234 / 34 (DI-62)	Malfunction in yaw rate sensor	<ul style="list-style-type: none"> Yaw rate sensor Yaw rate sensor circuit
C1210 / 36 (DI-120)	Zero point calibration of yaw rate sensor undone	<ul style="list-style-type: none"> Yaw rate sensor Yaw rate sensor circuit Neutral start switch circuit (P range)
C1207 / 37 (DI-44)	Malfunction in neutral start switch (P/R range)	<ul style="list-style-type: none"> Neutral start switch Neutral start switch circuit (P/R range)
C1336 / 39 (DI-120)	Zero point calibration of deceleration sensor	<ul style="list-style-type: none"> Deceleration sensor Deceleration sensor circuit Neutral start switch (P range) circuit
C1223 / 43 (DI-50)	Malfunction in ABS control system	ABS control system
C1224 / 44 (DI-51)	Open or short circuit in NE signal circuit	<ul style="list-style-type: none"> NEO circuit Engine and ECT ECU ABS & BA & TRC & VSC ECU
C1340 / 47 (DI-123)	Open circuit in center differential lock signal	<ul style="list-style-type: none"> Center differential lock system Center differential lock circuit
C1201 / 51 (DI-41)	Engine and ECT ECU system malfunction	Engine control system
C1203 / 53 (DI-42)	Engine and ECT ECU communication circuit malfunction	<ul style="list-style-type: none"> TRC+ or TRC- circuit ENG+ or ENG- circuit Engine and ECT ECU
Always ON (DI-130)	Malfunction in ABS & BA & TRC & VSC ECU Open circuit in VSC TRC warning light circuit	<ul style="list-style-type: none"> Power source circuit VSC TRC warning light circuit

HINT:

There is a case that hand-held tester cannot be used when VSC TRC warning light is always on.

PARTS LOCATION

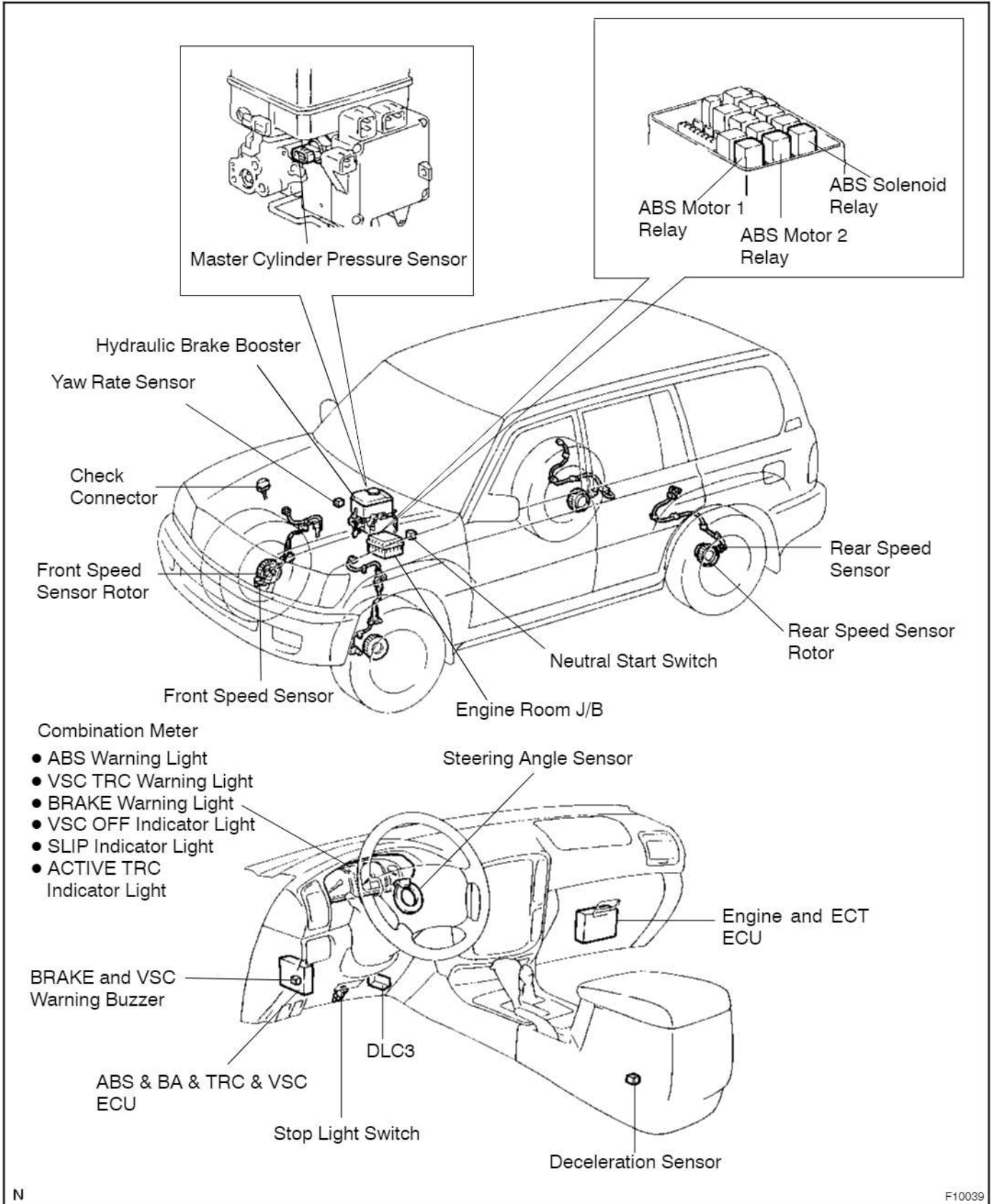

TERMINALS OF ECU

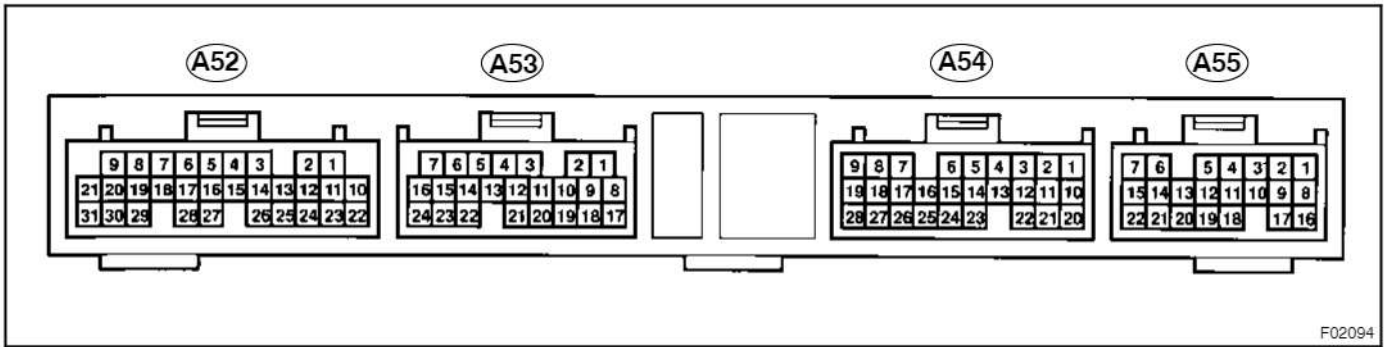

F02094

Symbols (Terminals No.)	Wiring Color	Condition	STD Voltage (V)
SA1 (A52 - 2) - GND (A52 - 6, 31, A53 - 8, 17)	G ↔ W-B	IG switch ON, ABS warning light OFF	10 - 14
SA2 (A52 - 3) - GND (A52 - 6, 31, A53 - 8, 17)	B ↔ W-B	IG switch ON, ABS warning light OFF	10 - 14
SA3 (A52 - 4) - GND (A52 - 6, 31, A53 - 8, 17)	G-W ↔ W-B	IG switch ON, ABS warning light OFF	10 - 14
STR (A52 - 5) - GND (A52 - 6, 31, A53 - 8, 17)	G-Y ↔ W-B	IG switch ON, ABS warning light OFF	10 - 14
SFLR (A52 - 7) - GND (A52 - 6, 31, A53 - 8, 17)	B-Y ↔ W-B	IG switch ON, ABS warning light OFF	10 - 14
SRRH (A52 - 8) - GND (A52 - 6, 31, A53 - 8, 17)	W ↔ W-B	IG switch ON, ABS warning light OFF	10 - 14
SRRR (A52 - 9) - GND (A52 - 6, 31, A53 - 8, 17)	B-O ↔ W-B	IG switch ON, ABS warning light OFF	10 - 14
VCM (A52 - 10) - GND (A52 - 6, 31, A53 - 8, 17)	B ↔ W-B	IG switch ON	4.5 - 5.5
PH (A52 - 11) - GND (A52 - 6, 31, A53 - 8, 17)	O ↔ W-B	IG switch ON, pressure switch (PH) ON	Below 0.9
		IG switch ON, pressure switch (PH) OFF	5 - 8
FR+ (A52 - 14) - FR- (A52 - 13)	L ↔ P	IG switch ON, slowly turn right front wheel	AC generation
FL+ (A52 - 16) - FL- (A52 - 15)	R ↔ G	IG switch ON, slowly turn left front wheel	AC generation
SR (A52 - 19) - R1+ (A52 - 1)	G-Y ↔ P	IG switch ON, ABS warning light OFF	10 - 14
SFLH (A52 - 21) - GND (A52 - 6, 31, A53 - 8, 17)	Y ↔ W-B	IG switch ON, ABS warning light OFF	10 - 14
PMC (A52 - 22) - E2 (A52 - 23)	R ↔ W	IG switch ON, stop light switch OFF	0.3 - 0.7
E2 (A52 - 23) - GND (A52 - 6, 31, A53 - 8)	W ↔ W-B	IG switch OFF	Continuity
MTT (A52 - 27) - GND (A52 - 6, 31, A53 - 8, 17)	B-R ↔ W-B	IG switch ON (Motor relay is OFF)	Below 1.5
MT+ (A52 - 28) - MT- (A52 - 18)	L ↔ GR	IG switch ON	Pulse generation
MR1 (A52 - 29) - R1+ (A52 - 1)	R ↔ P	IG switch ON, hydraulic brake booster pump motor stops	Below 1.0
WA (A53 - 1) - GND (A52 - 6, 31, A53 - 8, 17)	P-L ↔ W-B	IG switch ON, ABS warning light OFF	10 - 14

BZ (A53 - 2) - GND (A52 - 6, 31, A53 - 8, 17)	L ↔ W-B	IG switch ON, VSC buzzer is not sounded	10 - 14
D/G (A53 - 3) - GND (A52 - 6, 31, A53 - 8, 17)	V-W ↔ W-B	IG switch ON	10 - 14
R (A53 - 4) - GND (A52 - 6, 31, A53 - 8, 17)	R-B ↔ W-B	IG switch ON, transmission shift lever is in R range	10 - 14
P (A53 - 5) - GND (A52 - 6, 31, A53 - 8, 17)	G-W ↔ W-B	IG switch ON, transmission shift lever is in P range	10 - 14
IG1 (A53 - 6) - GND (A52 - 6, 31, A53 - 8, 17)	B-W ↔ W-B	IG switch ON	10 - 14
NEO (A53 - 7) - GND (A52 - 6, 31, A53 - 8, 17)	W ↔ W-B	Engine idling	Pulse generation
STP (A53 - 10) - GND (A52 - 6, 31, A53 - 8)	G-W ↔ W-B	Stop light switch pushed in	Below 1.5
		Stop light switch released	2 - 5
Tc (A53 - 11) - GND (A52 - 6, 31, A53 - 8, 17)	P-B ↔ W-B	IG switch ON and terminals Tc-E ₁ of check connector connected	Below 1.0
		IG switch ON and terminals Tc-E ₁ of check connector not connected	10 - 14
Ts (A53 - 12) - GND (A52 - 6, 31, A53 - 8, 17)	W ↔ W-B	IG switch ON and terminals Ts-E ₁ of check connector connected	Below 1.0
		IG switch ON and terminals Ts-E ₁ of check connector not connected	10 - 14
PKB (A53 - 13) - GND (A52 - 6, 31, A53 - 8, 17)	R-W ↔ W-B	IG switch ON, parking brake switch ON	Below 1.5
		IG switch ON, parking brake switch OFF	10 - 14
ENG+ (A53 - 14) - ENG - (A53 - 22)	R ↔ G	IG switch ON	Pulse generation
RL+ (A53 - 18) - RL- (A53 - 19)	R ↔ G	IG switch ON, slowly turn left rear wheel	AC generation
RR+ (A53 - 20) - RR- (A53 - 21)	B ↔ W	IG switch ON, slowly turn right rear wheel	AC generation
TRC+ (A53 - 24) - TRC- (A53 - 16)	Y ↔ L	IG switch ON	Pulse generation
VGS (A54 - 1) - GGND (A53 - 21)	B ↔ P	IG switch ON	4.5 - 5.5
EXI (A54 - 3) - GND (A52 - 6, 31, A53 - 8, 17)	P-B ↔ W-B	IG switch ON, center diff. lock switch ON	Below 2.0
		IG switch ON, center diff. lock switch OFF	10 - 14
VSCW (A54 - 4) - GND (A52 - 6, 31, A53 - 8, 17)	L-W ↔ W-B	IG switch ON, VSC TRC warning light ON	Below 2.0
		IG switch ON, VSC TRC warning light OFF	10 - 14
BRL (A54 - 5) - GND (A52 - 6, 31, A53 - 8, 17)	Y-G ↔ W-B	IG switch ON, BRAKE warning light ON	Below 2.0
		IG switch ON, BRAKE warning light OFF	10 - 14
IND (A54 - 6) - GND (A52 - 6, 31, A53 - 8, 17)	L-B ↔ W-B	IG switch ON, SLIP indicator light ON	Below 2.0
		IG switch ON, SLIP indicator light OFF	10 - 14
WT (A54 - 7) - GND (A52 - 6, 31, A53 - 8, 17)	L-R ↔ W-B	IG switch ON, VSC OFF indicator light ON	Below 2.0
		IG switch ON, VSC OFF indicator light OFF	10 - 14
EXI3 (A54 - 8) - GND (A52 - 6, 31, A53 - 8, 17)	B-L ↔ W-B	IG switch ON, transfer in L4 position	8 - 14
		IG switch ON, transfer in any range except L4 position	Below 1.5
VYS (A54 - 9) - GYAW (A54 - 28)	W-L ↔ W-R	IG switch ON	4.5 - 5.5

GL2 (A54 -10) - GGND (A54 -21)	Y ↔ P	IG switch ON, vehicle is placed on the horizontal surface	2.0 - 3.0
SS1+ (A54 -14) - SS1- (A54 -23)	W ↔ G	Engine idling, slowly turn steering wheel	Pulse generation
INFR (A54 -15) - GND (A52 - 6, 31, A53 - 8, 17)	B-R ↔ W-B	IG switch ON, ACTIVE TRC indicator light ON	Below 1.5
		IG switch ON, ACTIVE TRC indicator light OFF	10 - 14
YD (A54 -19) - GND (A52 - 6, 31, A53 - 8, 17)	L ↔ W-B	Approx. 1 sec. after IG switch ON	4.5 - 5.3
GGND (A54 -21) - GND (A52 - 6, 31, A53 - 8)	P ↔ W-B	IG switch OFF	Below 0.3
GL1 (A54 -22) - GGND (A54 -21)	V ↔ P	IG switch ON, vehicle is placed on the horizontal surface	2.0 - 3.0
FLO (A54 -24) - GND (A52 - 6, 31, A53 - 8, 17)	R-Y ↔ W-B	Vehicle driving at about 20 km/h (12 mph)	Pulse generation
GYAW (A54 -27) - GND (A52 - 6, 31, A53 - 8, 17)	W-R ↔ W-B	IG switch OFF	Continuity
YAW (A54 -28) - GYAW (A54 -27)	W ↔ W-R	IG switch ON, vehicle is in stationary condition	2 - 3
SRLR (A55 - 1) - GND (A52 - 6, 31, A53 - 8, 17)	R-G ↔ W-B	IG switch ON, ABS warning light OFF	10 - 14
MR2 (A55 - 2) - R2+ (A55 - 3)	Y-B ↔ W-L	IG switch ON, hydraulic brake booster pump motor stops	Below 1.0
AST (A55 - 6) - GND (A52 - 6, 31, A53 - 8, 17)	R-Y ↔ W-B	IG switch ON, ABS warning light OFF	10 - 14
SRLH (A55 - 7) - GND (A52 - 6, 31, A53 - 8, 17)	R-W ↔ W-B	IG switch ON, ABS warning light OFF	10 - 14
SFRR (A55 - 8) - GND (A52 - 6, 31, A53 - 8, 17)	B-W ↔ W-B	IG switch ON, ABS warning light OFF	10 - 14
PL (A55 - 9) - GND (A52 - 6, 31, A53 - 8, 17)	W ↔ W-B	IG switch ON, pressure switch ON	3 - 5
		IG switch ON, pressure switch OFF	7 - 11
AHC0 (A55 - 13) - GND (A52 - 6, 31, A53 - 8, 17)	R ↔ W-B	IG switch ON	Pulse generation
AHC1 (A55 - 14) - GND (A52 - 6, 31, A53 - 8, 17)	R-W ↔ W-B	IG switch ON	Pulse generation
SFRH (A55 - 16) - GND (A52 - 6, 31, A53 - 8, 17)	LG ↔ W-B	IG switch ON, ABS warning light OFF	10 - 14
WAHC (A55 - 18) - GND (A52 - 6, 31, A53 - 8, 17)	B-R ↔ W-B	IG switch ON, AHC indicator ON	2 - 6
		IG switch ON, AHC indicator OFF	Below 2.0
IG2 (A55 - 22) - GND (A52 - 6, 31, A53 - 8, 17)	*1 B-W ↔ W-B *2 B-R ↔ W-B	IG switch ON	10 - 14

*1: LHD

*2: RHD

PROBLEM SYMPTOMS TABLE

If a normal code is displayed during the DTC check but the problem still occurs, check the circuits for each problem symptom in the order given in the table below and proceed to the relevant troubleshooting page.

NOTICE:

When replacing ABS & BA & TRC & VSC ECU, sensor or etc., turn the ignition switch OFF.

Symptom	Suspect Area	See page
ABS does not operate. BA does not operate.	Only when 1. to 4. are all normal and the problem is still occurring, replace the ABS & BA & TRC & VSC ECU. 1. Reconfirm the DTC and check that the normal code is output. 2. IG power source circuit 3. Speed sensor circuit 4. Check the hydraulic brake booster with a checker or hand-held tester. If abnormal, check the hydraulic circuit for leakage (See page DI-168).	DI-4 DI-67 DI-25 BR-8
ABS does not operate efficiently. BA does not operate.	Only when 1. to 4. are all normal and the problem is still occurring, replace the ABS & BA & TRC & VSC ECU. 1. Reconfirm the DTC and check that the normal code is output. 2. Speed sensor circuit 3. Stop light switch circuit 4. Check the hydraulic brake booster with a checker or hand-held tester. If abnormal, check the hydraulic circuit for leakage (See page DI-168).	DI-4 DI-25 DI-82 BR-8
ABS warning light abnormal.	1. ABS warning light circuit 2. ABS & BA & TRC & VSC ECU	DI-133 IN-35
DTC check cannot be done.	Only when 1. to 3. are all normal and the problem is still occurring, replace the ABS & BA & TRC & VSC ECU. 1. ABS warning light circuit 2. VSC OFF indicator light, center diff. lock indicator switch circuit 3. Tc terminal circuit	DI-133 DI-156 DI-164
Speed sensor signal check cannot be done.	1. Ts terminal circuit 2. ABS & BA & TRC & VSC ECU	DI-166 IN-35
TRC does not operate.	Only when 1. to 4. are all normal and the problem is still occurring, replace the ABS & BA & TRC & VSC ECU. 1. Check the DTC, reconfirming that the normal code is output. 2. IG power source circuit 3. Check the hydraulic circuit for leakage. 4. Speed sensor circuit	DI-4 DI-67 DI-168 DI-25
VSC does not operate.	Only when 1. to 7. are all normal and the problem is still occurring, replace the ABS & BA & TRC & VSC ECU. 1. Check the DTC, reconfirming that the normal code is output. 2. IG power source circuit 3. Check the hydraulic circuit for leakage. 4. Speed sensor circuit 5. Deceleration sensor circuit 6. Yaw rate sensor circuit 7. Steering angle sensor circuit	DI-4 DI-71 DI-168 DI-25 DI-77 DI-62 DI-117
VSC TRC warning light abnormal.	1. VSC TRC warning light circuit 2. ABS & BA & TRC & VSC ECU	DI-138 IN-35

BRAKE warning light abnormal	1. BRAKE warning light circuit 2. ABS & BA & TRC & VSC ECU	DI-144 IN-35
SLIP indicator light abnormal.	1. SLIP indicator light circuit 2. ABS & BA & TRC & VSC ECU	DI-149 IN-35
VSC OFF indicator abnormal.	1. VSC OFF indicator light, center diff. lock switch circuit 2. ABS & BA & TRC & VSC ECU	DI-156 IN-35
ACTIVE TRC indicator light abnormal.	1. ACTIVE TRC indicator light circuit 2. ABS & BA & TRC & VSC ECU	DI-153 IN-35

CIRCUIT INSPECTION

DTC	C0200 / 31 to C0215 / 34	Speed Sensor Circuit
------------	---------------------------------	-----------------------------

CIRCUIT DESCRIPTION

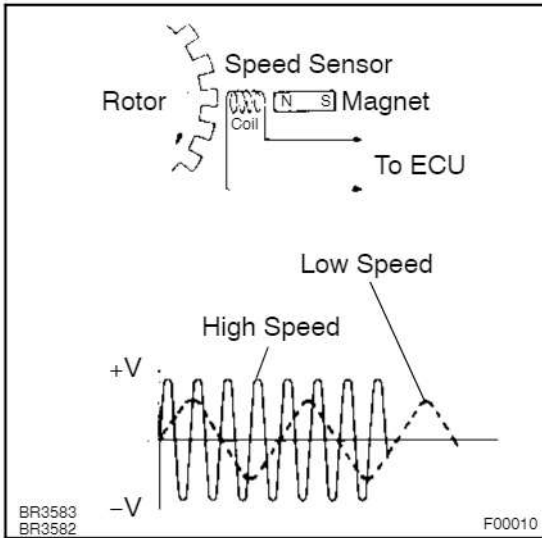

The speed sensor detects wheel speed and sends the appropriate signals to the ECU. These signals are used for control of both the ABS & BA & TRC & VSC control system. The front and rear rotors each have 48 serrations.

When the rotors rotate, the magnetic field emitted by the permanent magnet in the speed sensor generates an AC voltage. Since the frequency of this AC voltage changes in direct proportion to the speed of the rotor, the frequency is used by the ECU to detect the speed of each wheel.

DTC No.	DTC Detecting Condition	Trouble Area
C0200 / 31 C0205 / 32 C0210 / 33 C0215 / 34	Detection of any of conditions 1. through 4.: 1. At vehicle speed of 10 km/h (6 mph) or more, pulses are not input for 15 sec. 2. Momentary interruption of the speed sensor signal occurs at least 7 times in the time between switching the ignition switch ON and switching it OFF. 3. Continuous noise occurs into the speed sensor signals with the vehicle speed at 20 km/h (12 mph) or more. 4. The condition that the speed sensor signal circuit is open continues for 0.12 sec. or more.	<ul style="list-style-type: none"> • Right front, left front, right rear and left rear speed sensor • Each speed sensor circuit • Sensor rotor

HINT:

DTC No. C0200 / 31 is for the right front speed sensor.

DTC No. C0205 / 32 is for the left front speed sensor.

DTC No. C0210 / 33 is for the right rear speed sensor.

DTC No. C0215 / 34 is for the left rear speed sensor.

Fail safe function:

If trouble occurs in the speed sensor circuit, the ECU cuts off current to the ABS solenoid relay and prohibits ABS & BA & TRC & VSC controls and the brake system becomes normal.

WIRING DIAGRAM

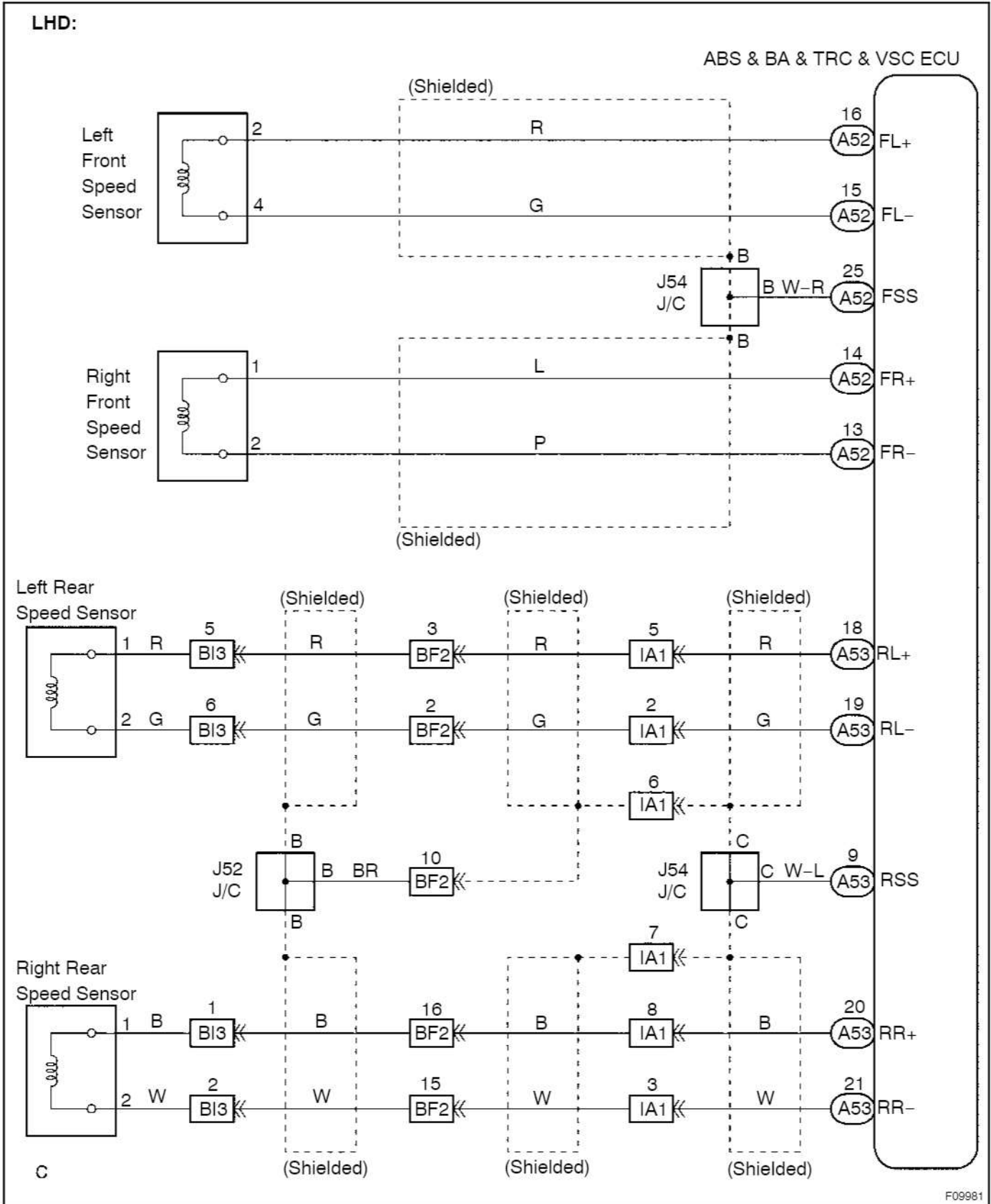

cardiagn.com

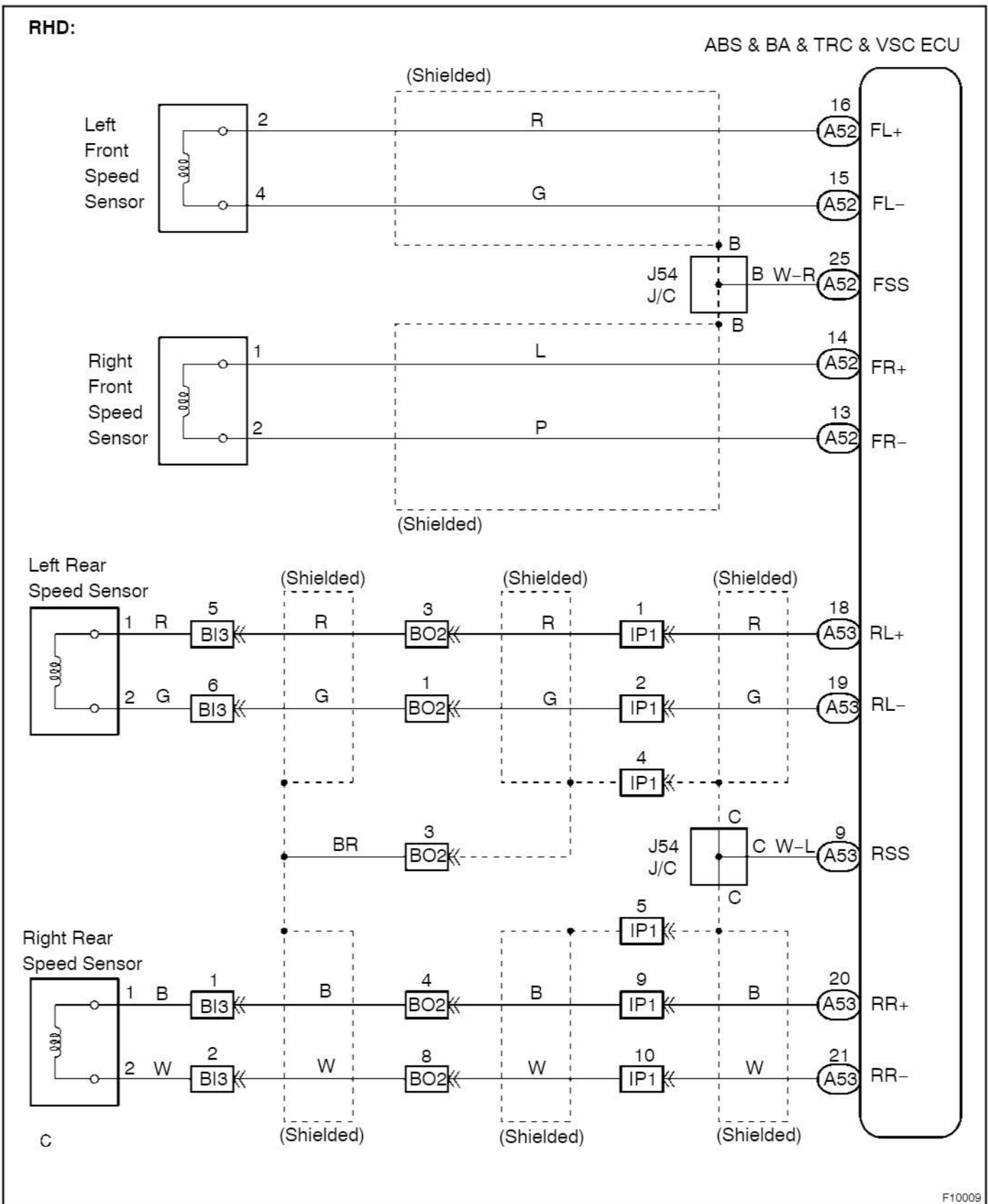

F10009

INSPECTION PROCEDURE**HINT:**

Start the inspection from step 1 in case of using the hand-held tester and start from step 2 in case of not using the hand-held tester.

1	Check output value of speed sensor.
----------	--

PREPARATION:

- (a) Connect the hand-held tester to the DLC3.
- (b) Turn the ignition switch ON and push the hand-held tester main switch ON.
- (c) Select the DATALIST mode on the hand-held tester.

CHECK:

Check that there is no difference between the speed value output from the speed sensor displayed on the hand-held tester and the speed value displayed on the speedometer when driving the vehicle.

OK:

There is almost no difference from the displayed speed value.

HINT:

There is tolerance of $\pm 10\%$ in the speedometer indication.

OK

Check and replace ABS & BA & TRC & VSC ECU.
--

NG

2	Check speed sensor.
----------	----------------------------

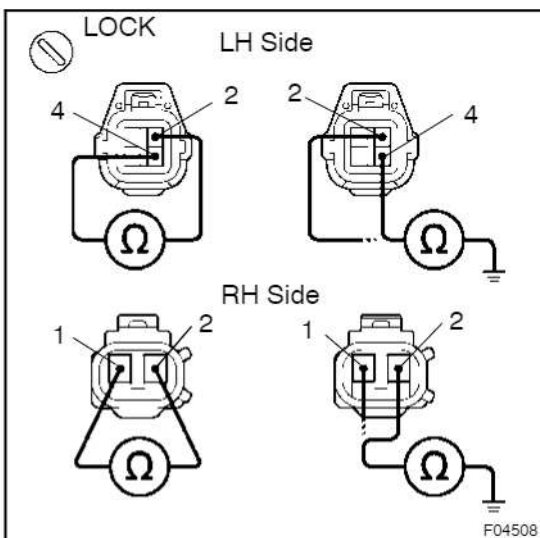
**Front:****PREPARATION:**

- (a) Make sure that there is no looseness at the connector lock part and connecting part of the connector.
- (b) Disconnect speed sensor connector.

CHECK:

- LH side:
Measure resistance between terminals 2 and 4 of speed sensor connector.
- RH side:
Measure resistance between terminals 1 and 2 of speed sensor connector.

OK:

Resistance: 0.92 – 1.22 k Ω

CHECK:

- LH side:
Measure resistance between terminals 2 and 4 of speed sensor connector and body ground.
- RH side:
Measure resistance between terminals 1 and 2 of speed sensor connector and body ground.

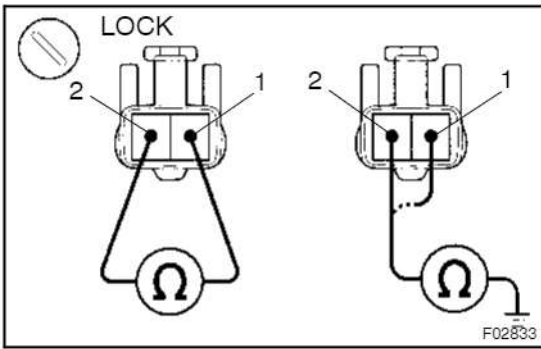

OK:

Resistance: 1 MΩ or higher

Rear:

PREPARATION:

- (a) Make sure that there is no looseness at the connector lock part and connecting part of the connector.
- (b) Disconnect speed sensor connector.

CHECK:

Measure resistance between terminals 1 and 2 of speed sensor connector.

OK:

Resistance: 1.0 – 1.4 kΩ

CHECK:

Measure resistance between terminal 1 or 2 of speed sensor connector and body ground.

OK:

Resistance: 1 MΩ or higher

NG	Replace speed sensor.
-----------	------------------------------

NOTICE:

Check the speed sensor signal last ([See page DI-4](#)).

OK

3	Check for open and short circuit in harness and connector between each speed sensor and ECU (See page IN-35).
----------	--

NG	Repair or replace harness or connector.
-----------	--

OK

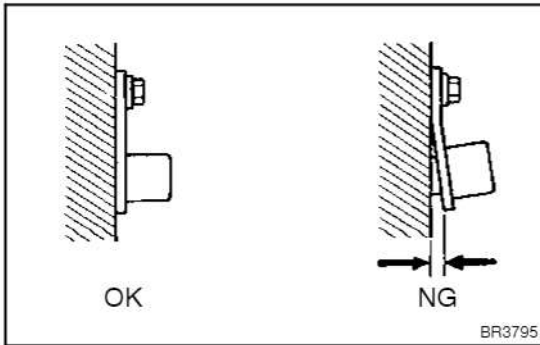
4 Check sensor installation.**CHECK:**

Check the speed sensor installation.

OK:

The installation bolt is tightened properly and there is no clearance between the sensor and front steering knuckle or rear axle shaft.

NG

Replace speed sensor.

NOTICE:

Check the speed sensor signal last (See page DI-4).

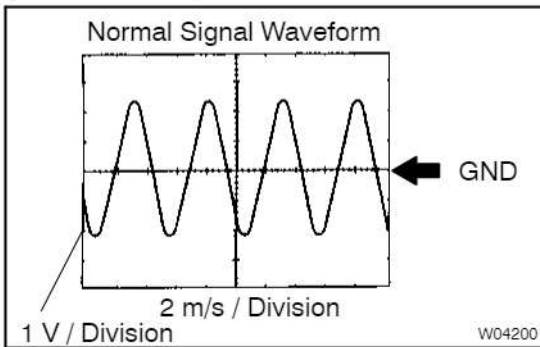
OK**5 Check speed sensor and sensor rotor serrations.****(REFERENCE) INSPECTION USING OSCILLOSCOPE****PREPARATION:**

- Remove the ABS & BA & TRC & VSC ECU.
- Connect the oscilloscope to the each of terminals FR+, FL+, RR+ or RL+ and GND of the ABS & BA & TRC & VSC ECU.

CHECK:

Drive the vehicle at about 20 km/h (12 mph), and check the signal waveform.

OK

Check and replace ABS & BA & TRC & VSC ECU.

NG

6 Check sensor rotor and sensor tip.

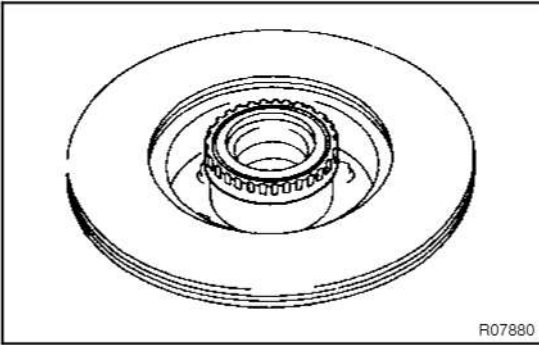

Front:

PREPARATION:

Remove front axle hub (See Pub No. RM616E on page SA-21).

CHECK:

Check the sensor rotor serrations.

OK:

No scratches, missing teeth or foreign objects.

PREPARATION:

Remove front speed sensor (See Pub No. RM616E on page BR-89).

CHECK:

Check the sensor tip.

OK:

No scratches or foreign objects on the sensor tip.

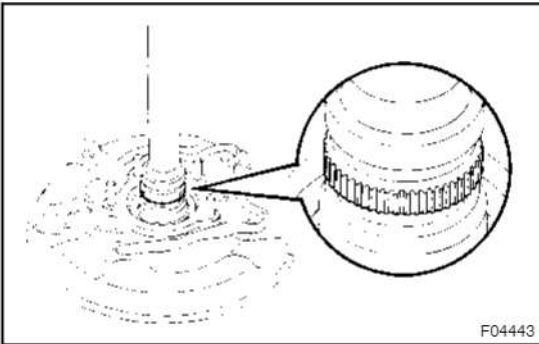

Rear:

PREPARATION:

Remove the rear axle shaft (See Pub No. RM616E on page SA-161).

CHECK:

Check the sensor rotor serrations.

OK:

No scratches, missing teeth or foreign objects.

PREPARATION:

Remove rear speed sensor (See Pub No. RM616E on page BR-92).

CHECK:

Check the sensor tip.

OK:

No scratches or foreign objects on the sensor tip.

NG	Replace speed sensor or rotor.
-----------	---------------------------------------

NOTICE:

Check the speed sensor signal last (See page DI-4).

OK

Check and replace ABS & BA & TRC & VSC ECU.
--

DTC	C0226 / 21 to C0256 / 24	ABS Solenoid Circuit
------------	---------------------------------	-----------------------------

CIRCUIT DESCRIPTION

This solenoid goes on when signals are received from the ECU and controls the pressure acting on the wheel cylinders thus controlling the braking force.

DTC No.	DTC Detecting Condition	Trouble Area
C0226 / 21	Open or short circuit in SFRH or SFRR circuit continues for 0.015 sec. or more.	<ul style="list-style-type: none"> • Hydraulic brake booster • SFRH or SFRR circuit
C0236 / 22	Open or short circuit in SFLH or SFLR circuit continues for 0.015 sec. or more.	<ul style="list-style-type: none"> • Hydraulic brake booster • SFLH or SFLR circuit
C0246 / 23	Open or short circuit in SRRH or SRRR circuit continues for 0.015 sec. or more.	<ul style="list-style-type: none"> • Hydraulic brake booster • SRRH or SRRR circuit
C0256 / 24	Open or short circuit in SRLH or SRLR circuit continues for 0.015 sec. or more.	<ul style="list-style-type: none"> • Hydraulic brake booster • SRLH or SRLR circuit

Fail safe function:

If trouble occurs in the actuator solenoid circuit, the ECU cuts off current to the ABS solenoid relay and prohibits ABS & BA & TRC & VSC controls and the brake system becomes normal.

WIRING DIAGRAM

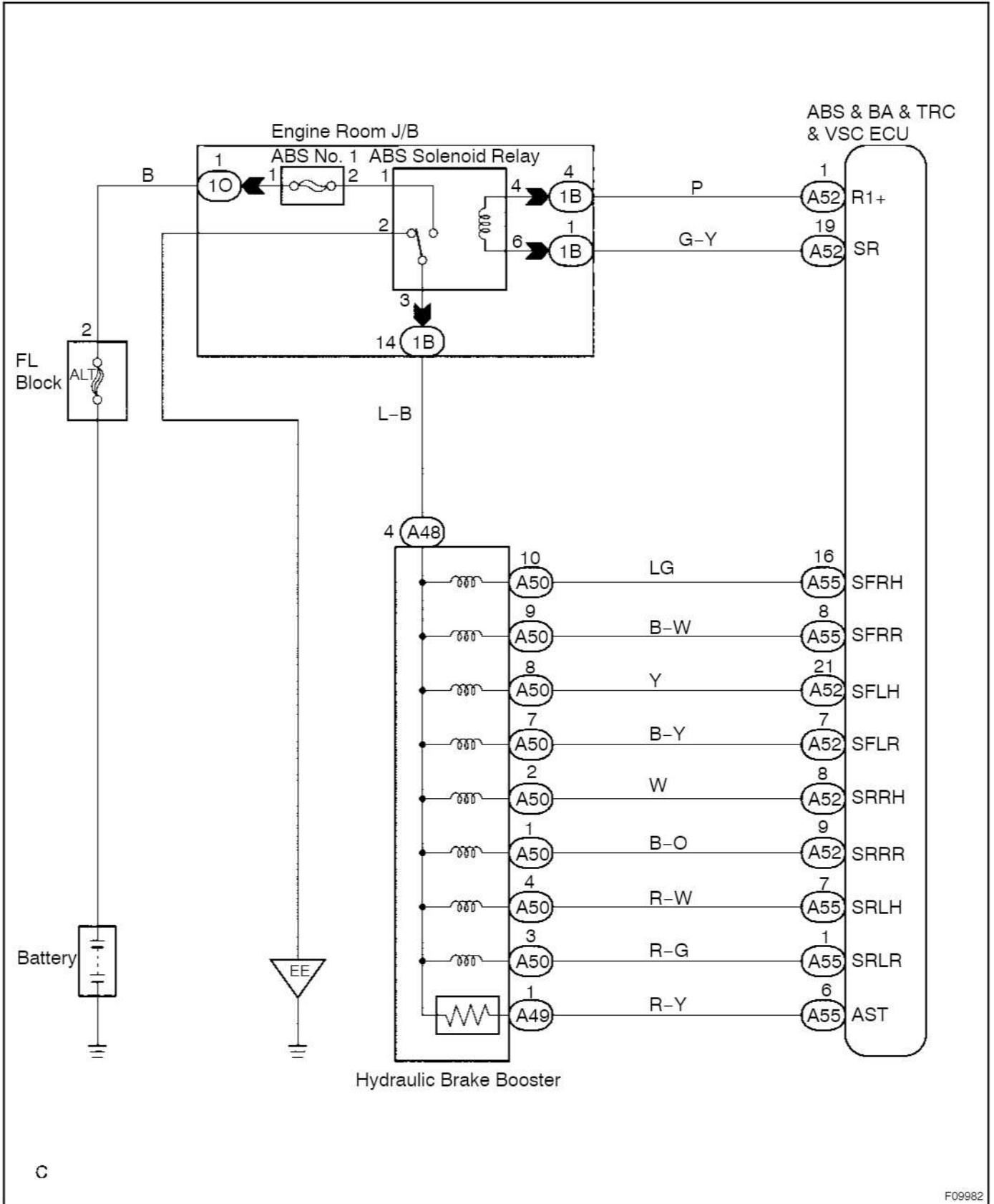

cardiagn.com

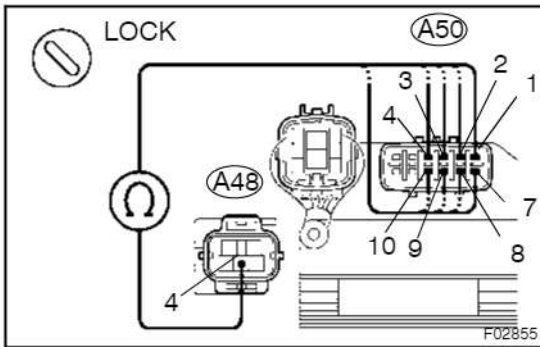
INSPECTION PROCEDURE**1 Check hydraulic brake booster solenoid.****PREPARATION:**

Disconnect the 2 connectors from hydraulic brake booster.

CHECK:

Check continuity between each of terminals A48 - 4 and A50 - 1, 2, 3, 4, 7, 8, 9 and 10 of hydraulic brake booster connector.

OK:**Continuity****HINT:**

Resistance of each solenoid at 20 °C (68 °F)

SFRH, SFLH, SRRH, SRLH: 4.75 - 5.25 Ω

SFRR, SFLR, SRRR, SRLR: 2.00 - 2.40 Ω

NG**Replace hydraulic brake booster.****OK****2 Check for open and short circuit in harness and connector between ABS & BA & TRC & VSC ECU and actuator (See page IN-35).****NG****Repair or replace harness or connector.****OK**

If the same code is still output after the DTC is deleted, check the contact condition of each connection. If the connections are normal, the ECU may be defective.

DTC	C0278 / 11, C0279 / 12	ABS Solenoid Relay Circuit
------------	-------------------------------	-----------------------------------

CIRCUIT DESCRIPTION

This relay supplies power to each ABS solenoid. After the ignition switch is turned ON, if the initial check is OK, the relay goes on.

DTC No.	DTC Detecting Condition	Trouble Area
C0278 / 11	Conditions 1. and 2. continue for 0.2 sec. or more: 1. ECU terminal IG1 voltage is 9.5 V to 17.0 V and the solenoid relay is ON, however, the contact point of the solenoid relay is OFF. 2. With solenoid relay ON, ECU terminal IG1 voltage becomes 9.5 V or less and the contact point of the solenoid relay does not become ON.	<ul style="list-style-type: none"> •ABS solenoid relay •ABS solenoid relay circuit
C0279 / 12	Immediately after ECU terminal IG1 becomes ON, and solenoid relay is OFF, however, when the condition that the solenoid relay due to the contact point is ON continues for 0.2 sec. or more.	

Fail safe function:

If trouble occurs in the ABS solenoid relay circuit, the ECU cuts off current to the ABS solenoid relay and prohibits ABS & BA & TRC & VSC controls and the brake system becomes normal.

cardiagn.com

WIRING DIAGRAM

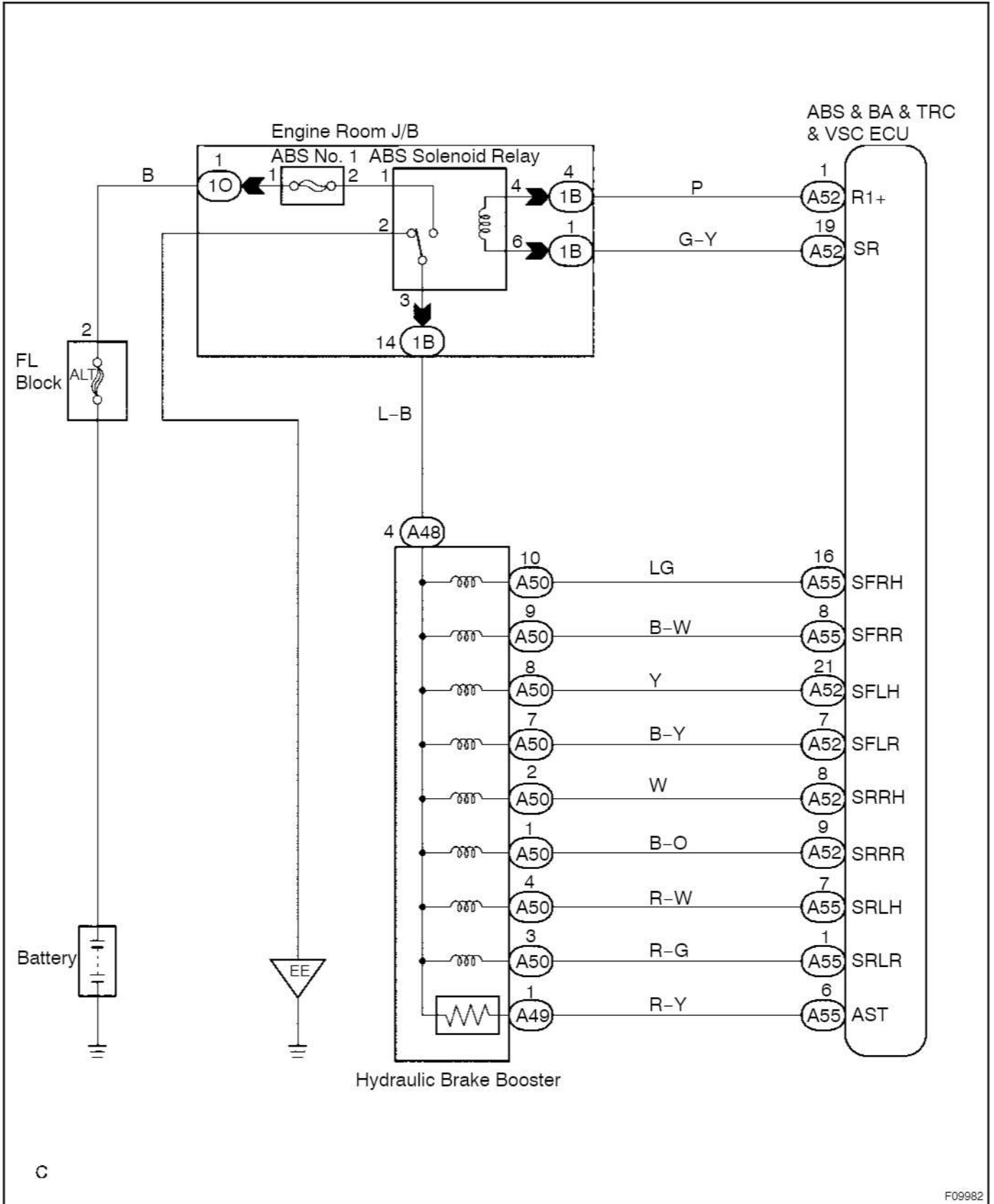

cardiagn.com

INSPECTION PROCEDURE

HINT:

Start the inspection from step 1 in case of using the hand-held tester and start from step 2 in case of not using the hand-held tester.

1	Check ABS solenoid relay operation.
----------	--

PREPARATION:

- (a) Connect the hand-held tester to the DLC3.
- (b) Turn the ignition switch ON and push the hand-held tester main switch ON.
- (c) Select the ACTIVE TEST mode on the hand-held tester.

CHECK:

Check the operation sound of the ABS solenoid relay when operating it with the hand-held tester.

OK:

The operation sound of the ABS solenoid relay should be heard.

OK	Go to step 6.
-----------	----------------------

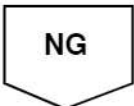

2	Check voltage between terminals 1 and 2 of engine room J/B (for ABS solenoid relay).
----------	---

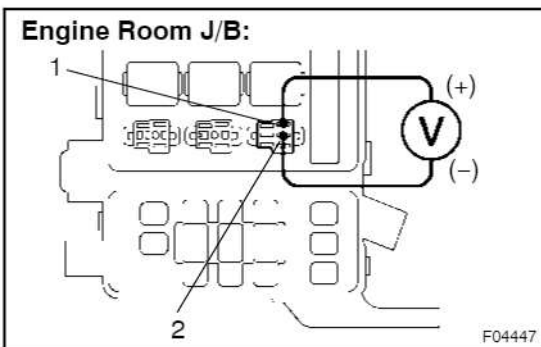

PREPARATION:

Remove ABS solenoid relay from engine room J/B.

CHECK:

Measure the voltage between terminals 1 and 2 of engine room J/B (for ABS solenoid relay).

OK:

Voltage: 10 - 14 V

NG	Check and repair harness or connector.
-----------	---

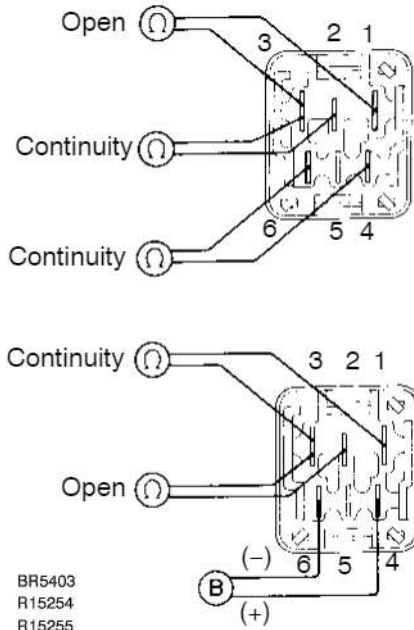
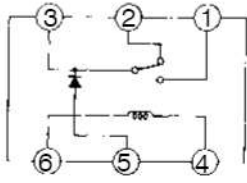

3 Check ABS solenoid relay.**PREPARATION:**

Remove ABS solenoid relay from engine room J/B.

CHECK:

Check continuity between each terminal of ABS solenoid relay.

OK:

Terminals 4 and 6	Continuity (Reference value 80 Ω)
Terminals 2 and 3	Continuity
Terminals 1 and 3	Open

CHECK:

- Apply battery voltage between terminals 4 and 6.
- Check continuity between each terminal of ABS solenoid relay.

OK:

Terminals 2 and 3	Open
Terminals 1 and 3	Continuity

NG**Replace ABS solenoid relay.****OK**

4 Check continuity between terminals 3 of ABS solenoid relay and terminal AST of ABS & BA & TRC & VSC ECU.

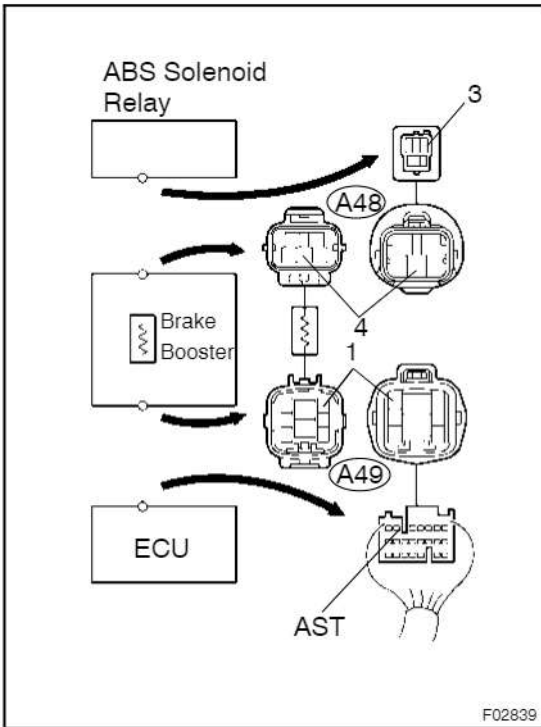

CHECK:

Check continuity between terminal 3 of ABS solenoid relay and terminal AST of ABS & BA & TRC & VSC ECU.

OK:

Continuity

HINT:

There is a resistance of $33 \pm 3 \Omega$ between terminals 4 of connector A48 and terminal 1 of connector A49.

NG Repair or replace harness, connector or hydraulic brake booster.

OK

5 Check for open and short circuit in harness and connector between ABS solenoid relay and ABS & BA & TRC & VSC ECU (See page IN-35).

NG Repair or replace harness or connector.

OK

If the same code is still output after the DTC is deleted, check the contact condition of each connection. If the connections are normal, the ECU may be defective.

6	Check for open circuit in harness and connector between AST of hydraulic brake booster and AST of ABS & BA & TRC & VSC ECU (See page IN-35).
----------	---

NG

Repair or replace harness or connector.

OK

Replace hydraulic brake booster or ABS &
BA & TRC & VSC ECU.

DTC	C1201 / 51	Engine Control System Malfunction
------------	-------------------	--

CIRCUIT DESCRIPTION

If trouble occurs in the engine control system, the ECU prohibits TRC and VSC control.

DTC No.	DTC Detecting Condition	Trouble Area
C1201 / 51	Conditions 1. and 2. continue for 5 sec.: 1. Engine speed: 500 rpm or more. 2. A trouble signal in the engine control system is input.	Engine control system

INSPECTION PROCEDURE

1	Check the DTC for the engine.
----------	--------------------------------------

*1

Repair engine control system according to the output code.

*2

Check for engine and ECT ECU connected to malfunction indicator light.

*1: Output NG code

*2: Malfunction indicator light remains ON

cardiagn.com

DTC	C1203 / 53	Engine and ECT ECU Communication Circuit Malfunction
------------	-------------------	---

CIRCUIT DESCRIPTION

The circuit is used to send TRC & VSC control information from the ABS & BA & TRC & VSC ECU to the engine and ECT ECU (TRC+, TRC-), and engine control information from the engine and ECT ECU to the ABS & BA & TRC & VSC ECU (ENG+, ENG-).

DTC No.	DTC Detecting Condition	Trouble Area
C1203 / 53	Either of the following 1. or 2. continues for 5 sec.: 1. ECU IG1 terminal voltage is 9.5 V to 17.0 V and data transmission to the engine and ECT ECU is impossible. 2. ECU IG1 terminal voltage is 9.5 V to 17.0 V, engine speed is 500 rpm or more or vehicle speed is 60 km/h (36 mph) or more and data receiving from the engine and ECT ECU is impossible.	<ul style="list-style-type: none"> •TRC+ or TRC- circuit •ENG+ or ENG- circuit •Engine and ECT ECU

Fail safe function:

If trouble occurs in the engine and ECT ECU communication circuit, the ECU prohibits TRC & VSC control.

WIRING DIAGRAM

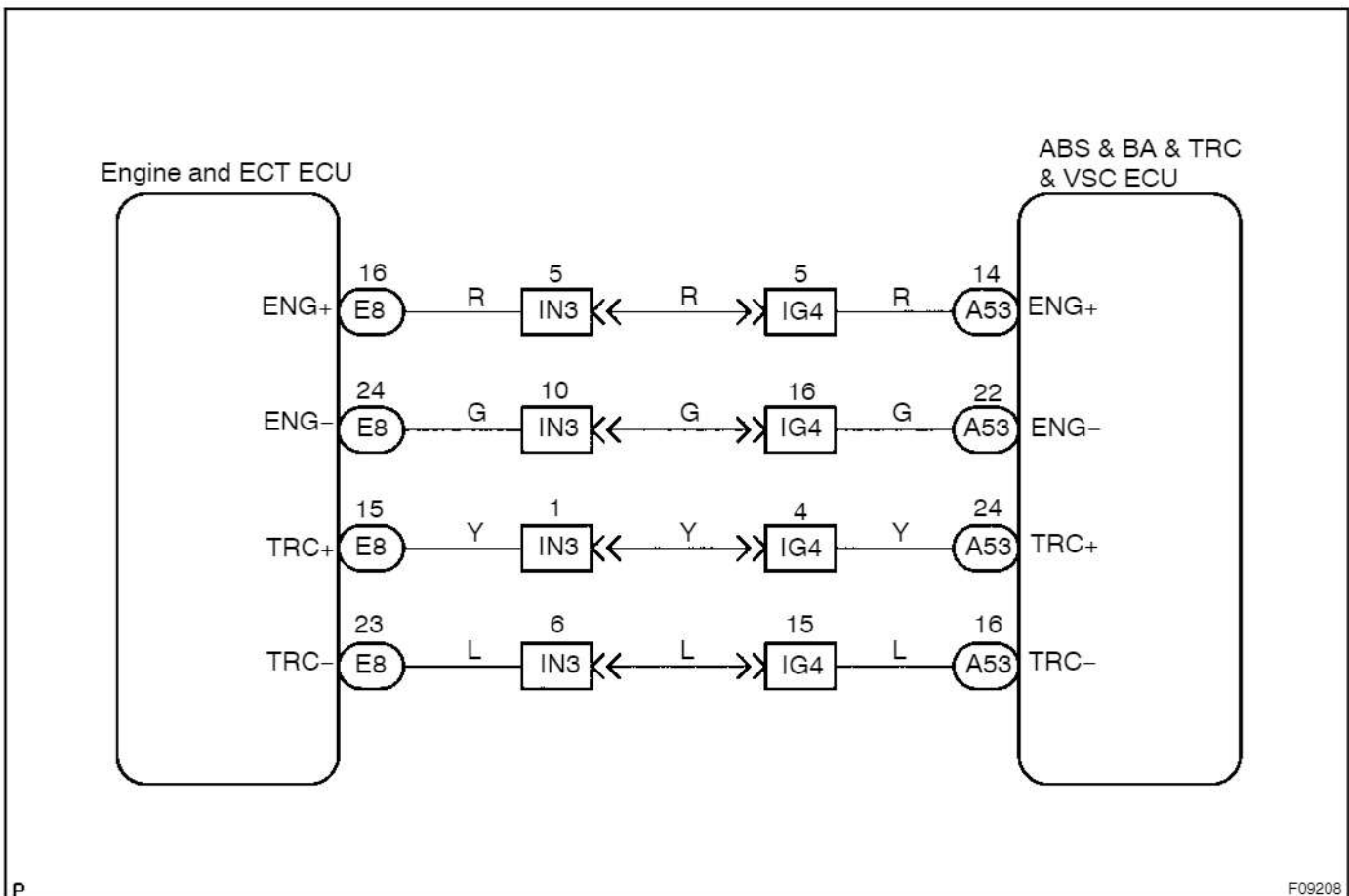

INSPECTION PROCEDURE

1	Check ABS & BA & TRC & VSC ECU communication.
----------	--

(REFERENCE) INSPECTION USING OSCILLOSCOPE

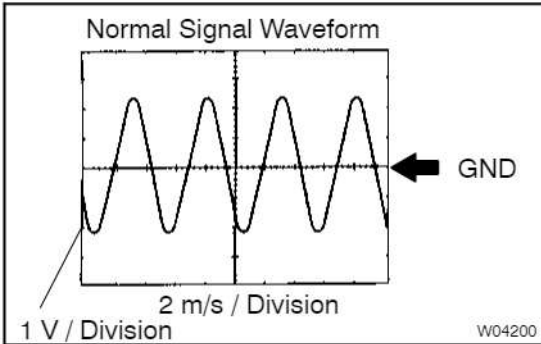

PREPARATION:

- (a) Remove the ABS & BA & TRC & VSC ECU.
- (b) Connect the oscilloscope to the each of terminals ENG+ or TRC+ and GND of the ABS & BA & TRC & VSC ECU.

CHECK:

Start the engine, and check the signal waveform.

NG	Check and replace ABS & BA & TRC & VSC ECU.
-----------	--

OK

2	Check for open and short circuit in harness and connector between each of terminals ENG+, ENG-, TRC+, TRC- of ABS & BA & TRC & VSC ECU and engine and ECT ECU (See page IN-35).
----------	--

NG	Repair or replace harness or connector.
-----------	--

OK

Check and replace engine and ECT ECU.
--

DTC	C1207 / 37	Neutral Start Switch Circuit (P/R Range)
------------	-------------------	---

CIRCUIT DESCRIPTION

DTC No.	DTC Detection Condition	Trouble Area
C1207 / 37	<p>When any of the following 1. through 3. is detected:</p> <ol style="list-style-type: none"> At vehicle speed of 15 km/h (9 mph) or less and the conditions that open circuit signal of P signal circuit of neutral start switch is ON and the voltage of IG1 terminal is 9.5 V to 17 V continue for 5 sec. or more. At vehicle speed of 15 km/h (9 mph) or more, and when the condition that P signal from neutral start switch is ON, and the the shift lever position information from the engine and ECT ECU is other than in P or N range continues for 60 sec. or more. At vehicle speed of 15 km/h (9 mph) or less and the conditions that open circuit signal of P signal circuit of neutral start switch is ON and the voltage of IG1 terminal is 9.5 V to 17 V continue for 5 sec. or more. 	<ul style="list-style-type: none"> • Neutral start switch • Neutral start switch circuit (P/R range)

WIRING DIAGRAM

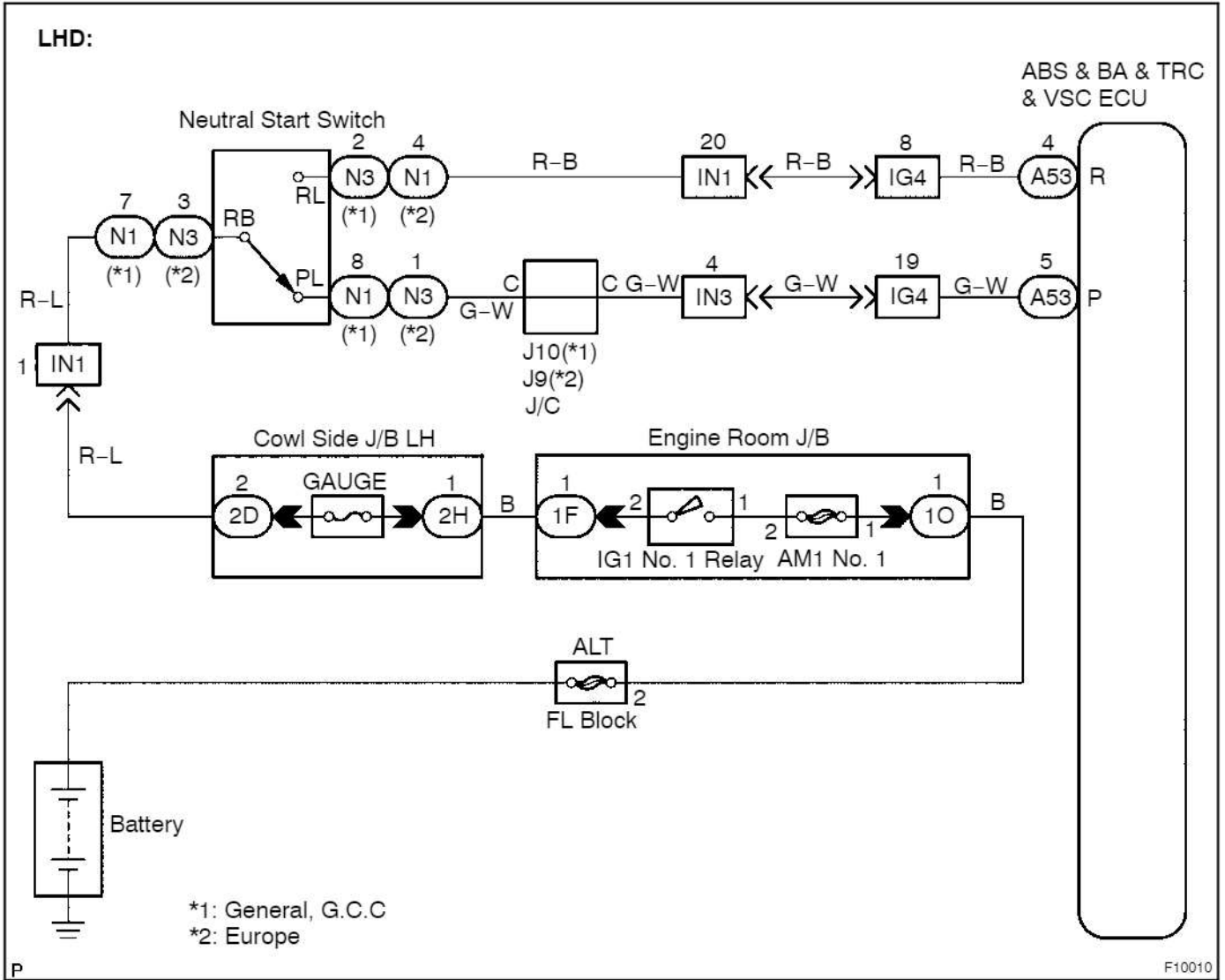

cardiagn.com

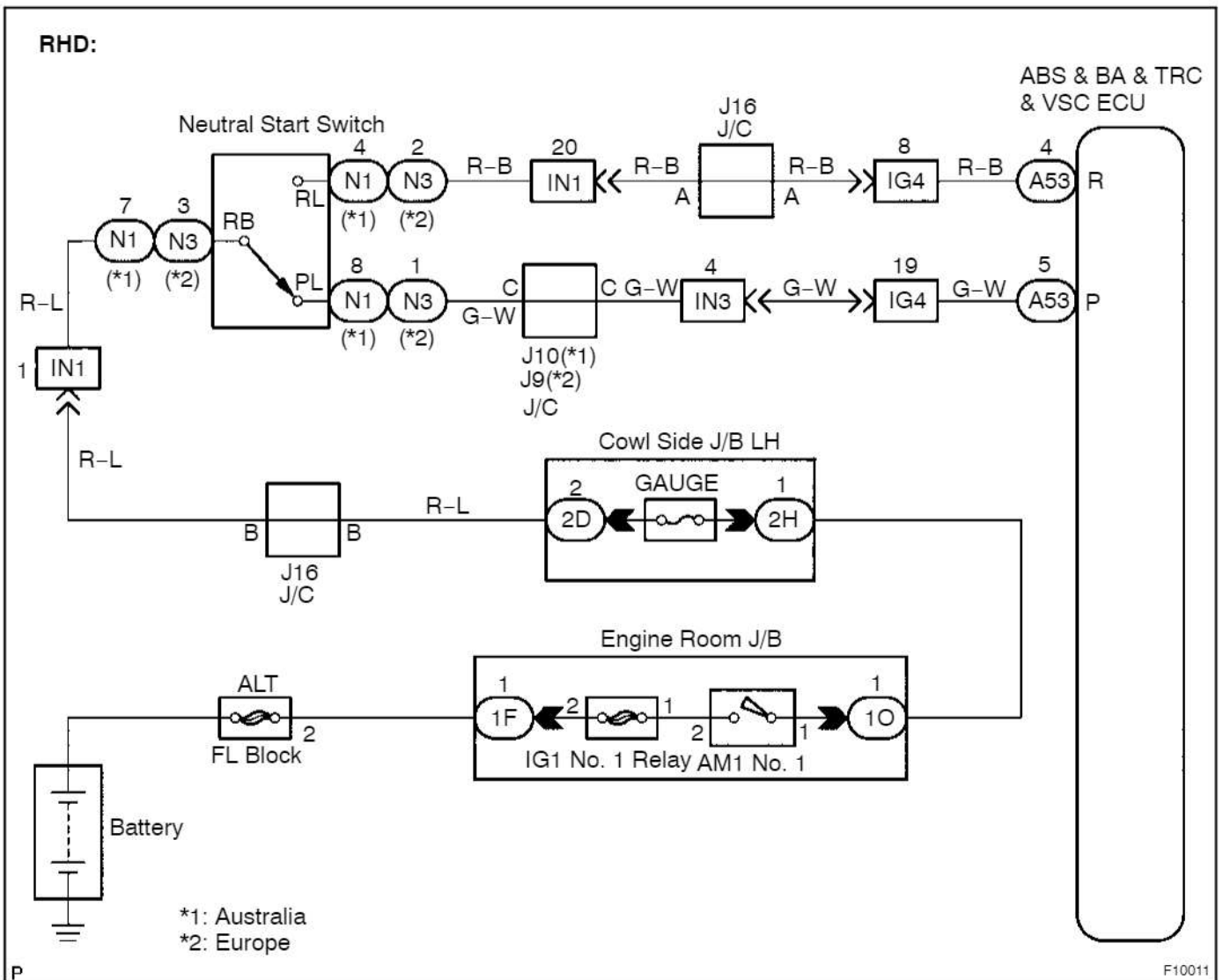

cardiagn.com

INSPECTION PROCEDURE

1 Check neutral start switch (P/R range).

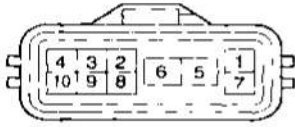

F10001

PREPARATION:

- (a) Jack up the vehicle.
- (b) Disconnect the neutral start switch connector.

CHECK:

Check continuity between each terminal shown below when the shift lever is moved to each range.

OK:

P range	Terminals 1 - 3	Continuity
R range	Terminals 2 - 3	Continuity

NG

Replace neutral start switch.

OK

2 Check for open and short circuit in harness and connector between terminals P and R of ABS & BA & TRC & VSC ECU and battery (See page IN-35).

NG

Repair or replace harness or connector.

OK

Check and replace ABS & BA & TRC & VSC ECU.

DTC	C1210 / 36	Zero Point Calibration of Yaw Rate Sensor Undone
------------	-------------------	---

CIRCUIT DESCRIPTION

DTC No.	DTC Detecting Condition	Trouble Area
C1210 / 36	When any of following 1. through 2. is detected: 1. After battery terminal was connected, when the shift lever was moved other than to P range within 15 sec. soon after ECU terminal IG1 become ON for the first time. 2. When the yaw rate sensor zero point recorded in ECU is deleted.	<ul style="list-style-type: none"> •Yaw rate sensor •Yaw rate sensor circuit •Neutral start switch circuit (P range)

WIRING DIAGRAM

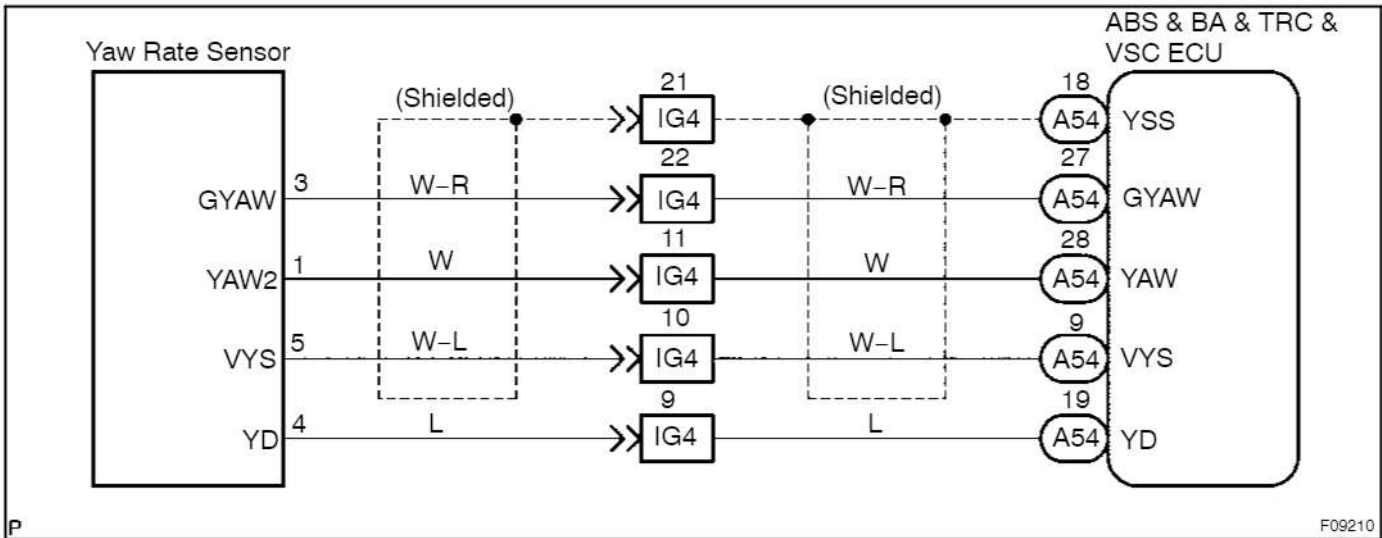

INSPECTION PROCEDURE

1	Check whether zero point calibration of yaw rate sensor has been done or not.
----------	--

PREPARATION:

Shift the shift lever in P range and turn the ignition switch ON, repeat connecting and releasing Ts and E₁ terminals of check connector 4 times or more for 8 sec. After that do not move the vehicle for 15 sec. or more.

CHECK:

Check that the "VSC TRC" warning light and "VSC OFF" indicator light up for 15 sec.

YES	No problem.
------------	--------------------

NO

2 Check for open and short circuit in harness and connector between neutral start switch (P range) and ABS & BA & TRC & VSC ECU and engine and ECT ECU (See page IN-35).

NG Repair or replace harness or connector.

OK

3 Check for open and short circuit in harness and connector between yaw rate sensor and ABS & BA & TRC & VSC ECU (See page IN-35).

NG Repair or replace harness or connector.

OK

4 Check yaw rate sensor (See page DI-62).

NG Replace yaw rate sensor.

OK

Check and replace ABS & BA & TRC & VSC ECU.

cardiagn.com

DTC	C1223 / 43	ABS Control System Malfunction
------------	-------------------	---------------------------------------

CIRCUIT DESCRIPTION

DTC No.	DTC Detecting Condition	Trouble Area
C1223 / 43	ABS control system is abnormal.	ABS control system

INSPECTION PROCEDURE

1	Check the DTC for the ABS (See page DI-4).
----------	---

*1

Repair ABS control system according to the code output.

*2

Check for ECU connected to malfunction indicator light.

*1: Output NG code

*2: Malfunction indicator light remains ON

DTC	C1224 / 44	NE Signal Circuit
------------	-------------------	--------------------------

CIRCUIT DESCRIPTION

The ABS & BA & TRC & VSC ECU receives engine revolution speed signals (NE signals) from the engine and ECT ECU.

DTC No.	DTC Detecting Condition	Trouble Area
C1224 / 44	When any of the following 1. through 2. is detected: 1. At vehicle speed of 30 km/h (19 mph) or more, and when data received from the engine and ECT ECU is in normal condition, and open or short circuit for engine revolution signal circuit continues for 10 sec. or more. 2. While TRC is operating, the conditions that open or short circuit in engine revolution signal circuit is detected, main throttle opening degree is 0 and IDL switch is OFF continue for 0.24 sec. or more.	<ul style="list-style-type: none"> •NEO circuit •Engine and ECT ECU •ABS & BA & TRC & VSC ECU

Fail safe function:

If trouble occurs in the NE signal circuit, the ECU prohibits TRC & VSC controls.

WIRING DIAGRAM

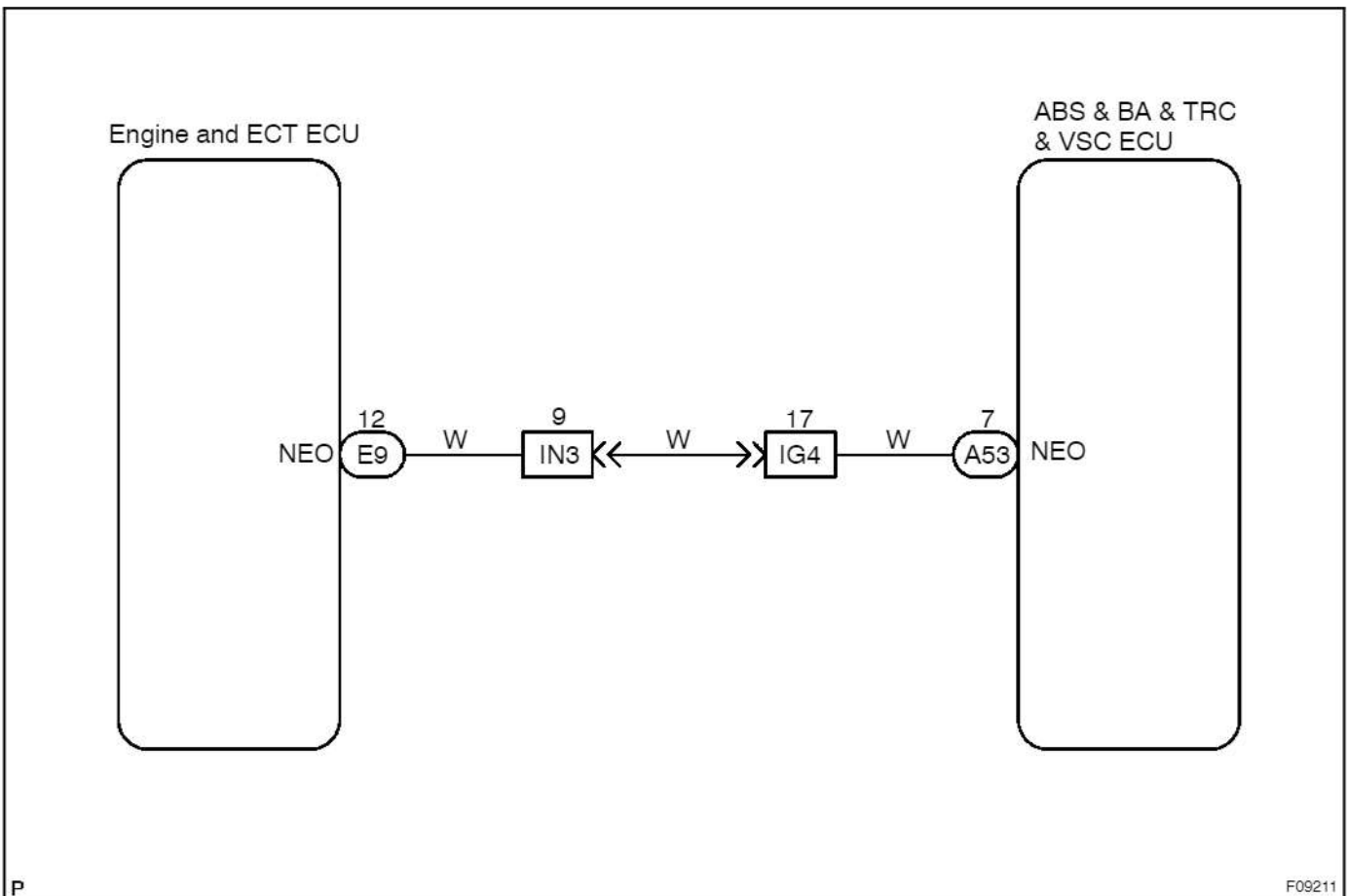

INSPECTION PROCEDURE

- 1 Check for open and short circuit in harness and connector between terminal NEO of ABS & BA & TRC & VSC ECU and terminal NEO of engine and ECT ECU (See page IN-35).

NG

Repair or replace harness and connector.

OK

- 2 Check voltage between terminal NEO of ABS & BA & TRC & VSC ECU and body ground.

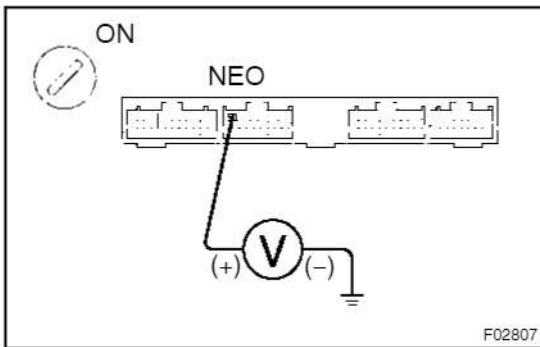
**PREPARATION:**

Remove ABS & BA & TRC & VSC ECU with connectors still connected.

CHECK:

- Turn the ignition switch ON.
- Measure voltage between terminal NEO of ABS & BA & TRC & VSC ECU and body ground for the engine conditions below.

OK:

Engine condition	Voltage
OFF (IG ON)	3 - 6 V or below 1 V
ON (Idling)	3 - 6 V ↔ below 1 V (Pulse)

(Reference)

3 - 6 V

Below 1 V

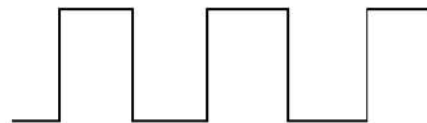

F03007

NG

Check and replace ABS & BA & TRC & VSC ECU or engine and ECT ECU.

OK

If the same codes is still output after the DTC is deleted, check the contact condition of each connection.

DTC	C1225 / 25 to C1228 / 28	TRC & VSC Solenoid Circuit
------------	---------------------------------	---------------------------------------

CIRCUIT DESCRIPTION

The TRC & VSC solenoid operates in accordance with signals from the ECU and raises the fluid pressure in and releases it from the brake cylinders.

DTC No.	DTC Detecting Condition	Trouble Area
C1225 / 25	Open or short circuit for SA1 circuit continues for 0.015 sec. or more.	<ul style="list-style-type: none"> Hydraulic brake booster SA1 circuit
C1226 / 26	Open or short circuit for SA2 circuit continues for 0.015 sec. or more.	<ul style="list-style-type: none"> Hydraulic brake booster SA2 circuit
C1227 / 27	Open or short circuit for SA3 circuit continues for 0.015 sec. or more.	<ul style="list-style-type: none"> Hydraulic brake booster SA3 circuit
C1228 / 28	Open or short circuit for STR circuit continues for 0.015 sec. or more.	<ul style="list-style-type: none"> Hydraulic brake booster STR circuit

Fail safe function:

If trouble occurs in the actuator solenoid circuit, the ECU cuts off current to the ABS solenoid relay and prohibits ABS & BA & TRC & VSC controls and the brake system becomes normal.

WIRING DIAGRAM

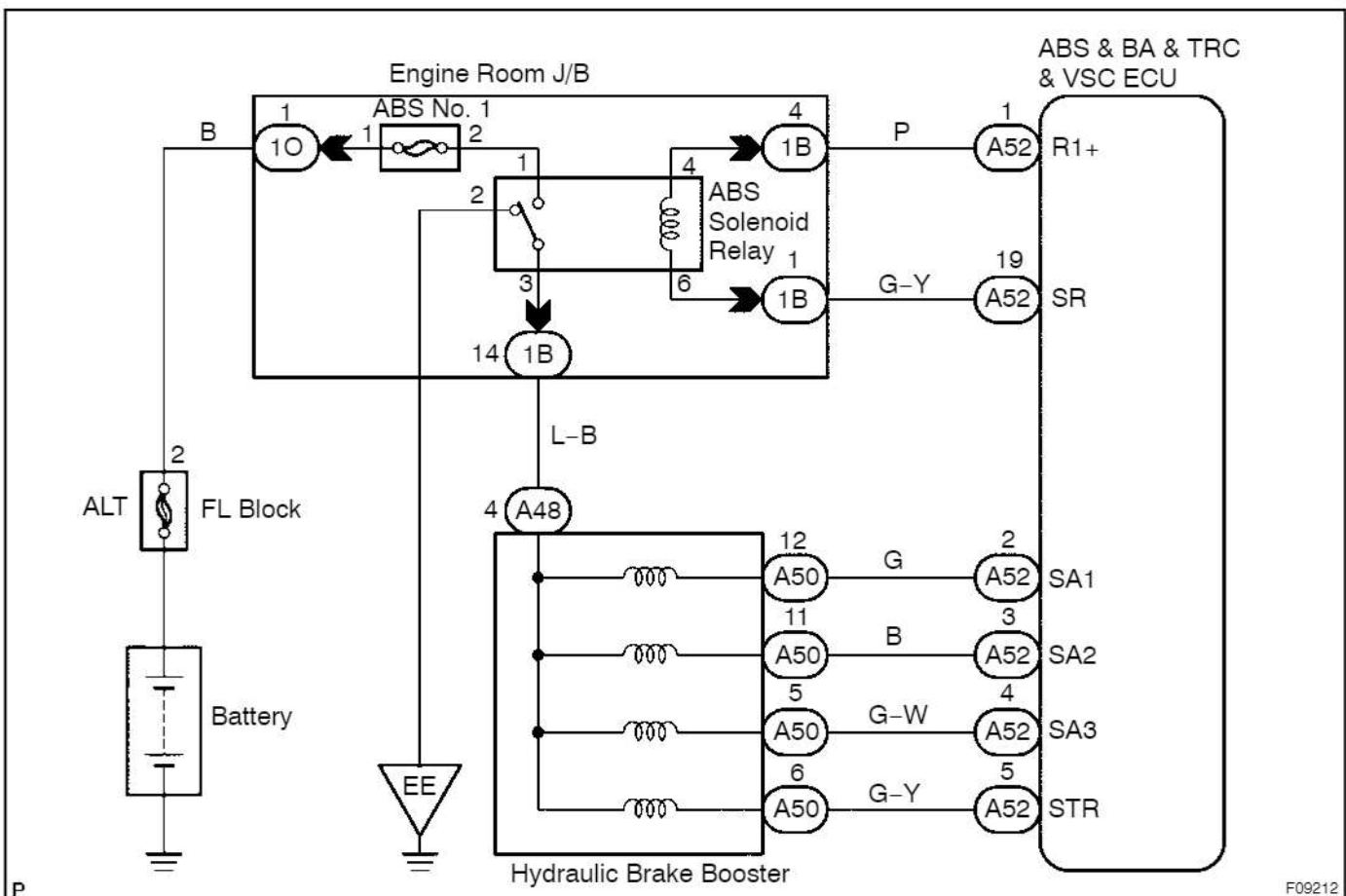

INSPECTION PROCEDURE

1 Check TRC & VSC solenoid.

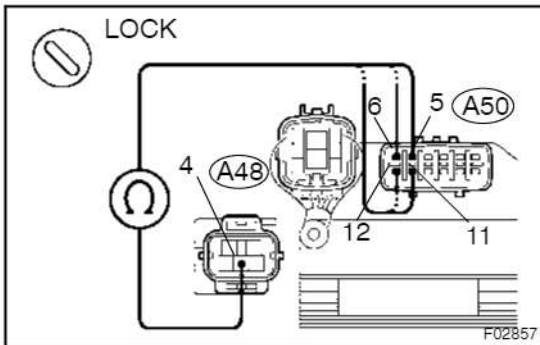

PREPARATION:

Disconnect the 2 connectors from hydraulic brake booster.

CHECK:

Check continuity between terminals A48 - 4 and A50 - 5, 6, 11 and 12 of hydraulic brake booster.

OK:

Continuity

HINT:

Resistance of each solenoid at 20 °C (68 °F)

SA1, SA2, STR: 3.5 - 3.9 Ω

SA3: 4.75 - 5.25 Ω

NG

Replace hydraulic brake booster.

OK

2 Check for open and short circuit in harness and connector between ABS & BA & TRC & VSC ECU and hydraulic brake booster (See page IN-35).

NG

Repair or replace harness or connector.

OK

If the same code is still output after the DTC is deleted, check the contact condition of each connection. If the connections are normal, the ECU may be defective.

DTC	C1231 / 31	Steering Angle Sensor Circuit
------------	-------------------	--------------------------------------

CIRCUIT DESCRIPTION

DTC No.	DTC Detecting Condition	Trouble Area
C1231 / 31	Detection of any of conditions 1. through 3.: 1. When the condition that ECU terminal IG1 voltage is 9.5 V or more, and does not receive a data from steering angle sensor continues for 1 sec. or more. 2. When the steering angle sensor value changes by 360° or more with SSC signal from steering angle sensor remaining ON or OFF. 3. When the condition that difference between the steering angle value at edge occurring in SSC signal and the value at edge occurring in SSC signal after turning the steering wheel one-turn is out of the range from 355.5° - 364.5° occurs 10 times or more.	<ul style="list-style-type: none"> •Steering angle sensor •Steering angle sensor circuit

Fail safe function:

If trouble occurs in the steering angle sensor circuit, the ECU prohibits TRC & VSC controls.

WIRING DIAGRAM

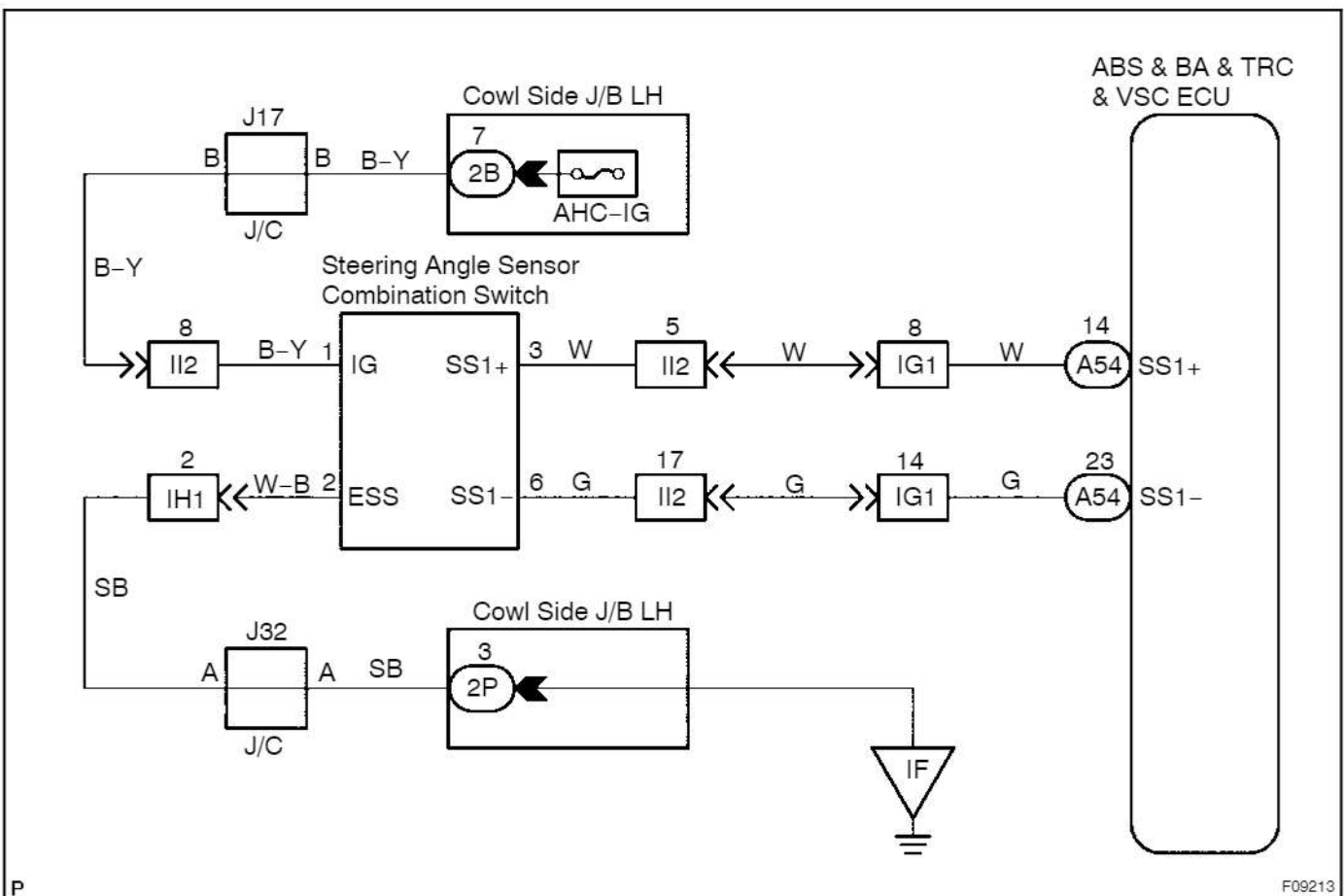

cardiagn.com

INSPECTION PROCEDURE

HINT:

Start the inspection from step 1 in case of using the hand-held tester and start from step 2 in case of not using the hand-held tester.

1	Check output value of the steering angle sensor.
----------	---

PREPARATION:

- (a) Connect the hand-held tester to the DLC3.
- (b) Turn the ignition switch ON and push the hand-held tester main switch ON.
- (c) Select the DATALIST mode on the hand-held tester.

CHECK:

Check that the steering wheel turning angle value of the steering angle position sensor displayed on the hand-held tester is changing when turning the steering wheel.

OK:

Steering wheel turning angle value must be changing.

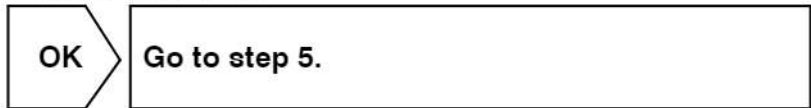

2	Replace the ECU and check whether or not the trouble occurs again.
----------	---

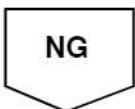

END

cardiagn.com

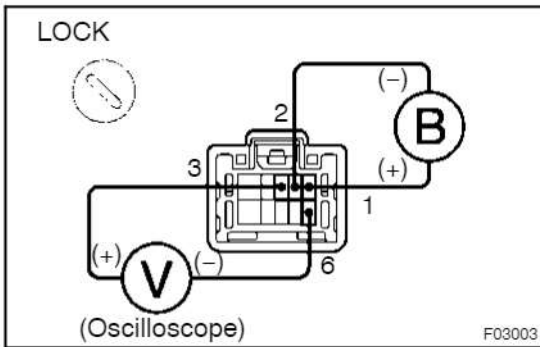
3 Check steering angle sensor.**PREPARATION:**

- Remove the steering wheel lower No. 2 and No. 3 covers, steering wheel pad, steering wheel column upper and lower covers (See Pub. No. RM616E on page SR-13 or SR-29).
- Disconnect the combination switch connector (for steering angle sensor).
- Connect the oscilloscope to the terminals 3 and 6 of the combination switch connector (for steering angle sensor).
- Apply battery voltage between terminals 1 and 2.

CHECK:

Turns the steering wheel slowly and check the signal waveform.

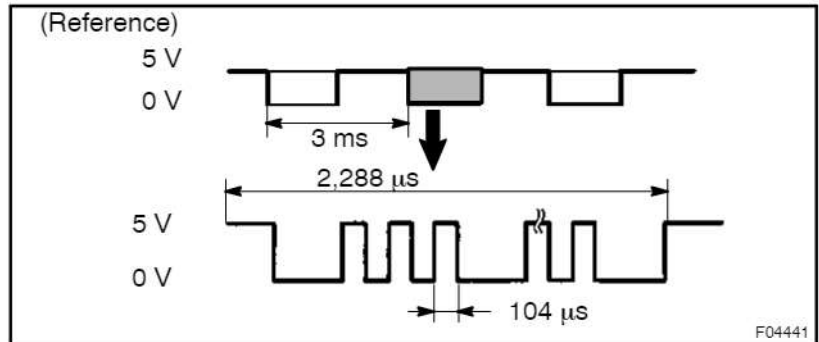
OK:**HINT:**

The above signal waveform does not repeat ON and OFF regularly and this combination changes case by case according to the data.

NG**Replace steering angle sensor.****OK****4 Check that slits of the steering sensor disc are clogged up.****NG****Repair or replace steering sensor disc.****OK**

5 Check for open and short circuit in harness and connector between steering position sensor and ABS & BA & TRC & VSC ECU (See page IN-35).

NG

Repair or replace harness or connector.

OK

Check and replace ABS & BA & TRC & VSC ECU.

DTC	C1232 / 32	Deceleration Sensor Circuit
------------	-------------------	------------------------------------

CIRCUIT DESCRIPTION

DTC No.	DTC Detecting Condition	Trouble Area
C1232 / 32	Detection of either of conditions 1. and 2.: 1. At the vehicle speed of 10 km/h (6 mph) or more, when the condition that ECU terminal GL1 signal change range is less than 20 mV, and ECU terminal GL2 signal change range swings by 468 mV or more occurs for 30 sec. or more. 2. At the vehicle speed of 10 km/h (6 mph) or more, when the condition that ECU terminal GL2 signal change range is less than 20 mV, and ECU terminal GL1 signal change range swings by 468 mV or more occurs for 30 sec. or more.	<ul style="list-style-type: none"> • Deceleration sensor • Deceleration sensor circuit

Fail safe function:

If trouble occurs in the deceleration sensor circuit, the ECU prohibits TRC & VSC controls.

INSPECTION PROCEDURE

HINT:

Start the inspection from step 1 in case of using the hand-held tester and start from step 2 in case of not using the hand-held tester.

1	Check output value of the deceleration sensor.
----------	---

PREPARATION:

- (a) Connect the hand-held tester to the DLC3.
- (b) Turn the ignition switch ON and push the hand-held tester main switch ON.
- (c) Select the DATALIST mode on the hand-held tester.

CHECK:

Check that the deceleration value of the deceleration sensor displayed on the hand-held tester is changing when tilting the vehicle.

OK:

Deceleration value must be changing.

OK

Check and replace ABS & BA & TRC & VSC ECU.

NG

2 Check deceleration sensor (See page DI-4).

NG

Replace deceleration sensor.

OK

3 Check for open or short circuit in harness and connector between deceleration sensor and ABS & BA & TRC & BA & VSC ECU (See page IN-35).

NG

Repair or replace harness and connector.

OK

Check and replace ABS & BA & TRC & VSC ECU.

DTC	C1233 / 33, C1234 / 34	Yaw Rate Sensor Circuit
------------	-------------------------------	--------------------------------

CIRCUIT DESCRIPTION

DTC No.	DTC Detecting Condition	Trouble Area
C1233 / 33	<p>When any of the following 1. through 4. is detected:</p> <ol style="list-style-type: none"> 1. ECU terminal IG1 voltage is 9.5 V to 17.0 V, and the condition that yaw rate sensor voltage is out of the range from 0.25 V to 4.75 V continued for 1 sec. or more. 2. The conditions that yaw rate sensor open detect circuit signal is ON and the voltage of ECU terminal IG1 is 9.5 V to 17 V continued for 1 sec. or more. 3. The conditions that yaw rate sensor power source voltage is out of the range from 4.4 V to 5.6 V and the voltage of ECU terminal IG1 is 9.5 V to 17 V continued for 1 sec. or more. 4. When the condition that yaw rate sensor signal is momentarily open occurs 10 times or more and the voltage of ECU terminal IG1 is 9.5 V to 17 V. 	<ul style="list-style-type: none"> • Yaw rate sensor • Yaw rate sensor circuit
C1234 / 34	<p>Condition 1. or 2. is detected:</p> <ol style="list-style-type: none"> 1. When the condition that yaw rate sensor VYS terminal voltage is 4.75 V to 5.25 V and YD malfunction signal of yaw rate sensor is ON continued for 5 sec. or more. 2. Shift lever position is in P range and output voltage of yaw rate sensor is out of the range from 2.4 V to 2.6 V or after the difference from zero point calibration voltage of yaw rate sensor has become 0.08 V or more and when the condition that the vehicle speed exceeds more than 15 km/h (9 mph) while output condition of yaw rate sensor has been repeated more than 3 times. 	

Fail safe function:

If trouble occurs in the yaw rate sensor circuit, the ECU prohibits TRC & VSC controls.

WIRING DIAGRAM

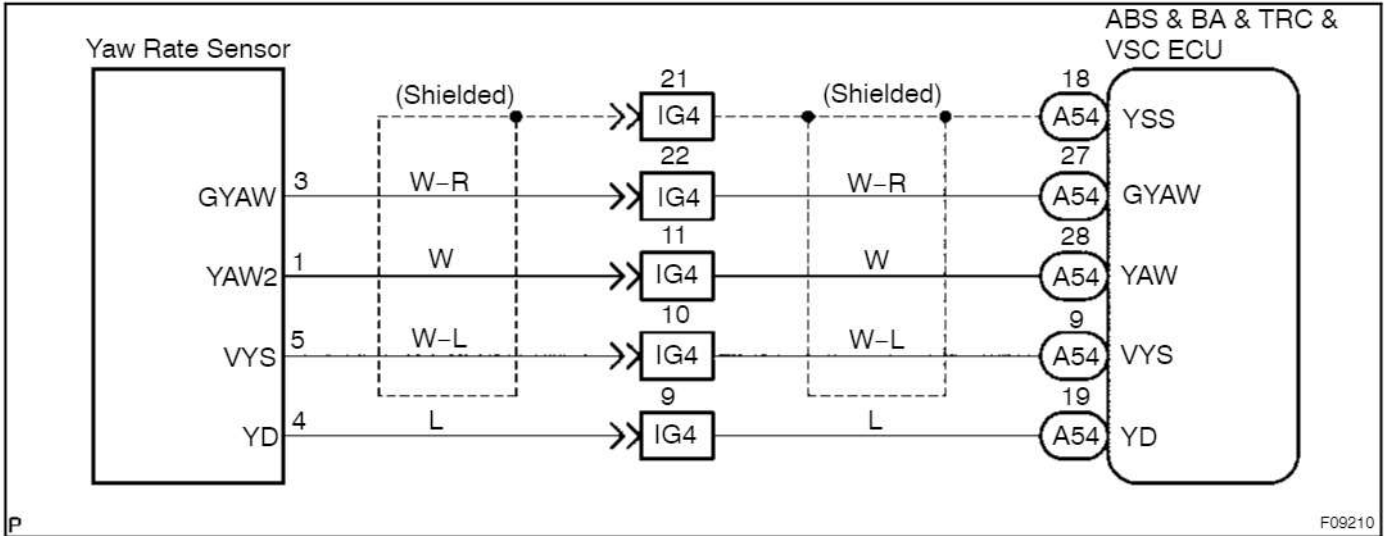

INSPECTION PROCEDURE

HINT:

Start the inspection from step 1 in case of using the hand-held tester and start from step 2 in case of not using the hand-held tester.

1	Check output value of the yaw rate sensor.
----------	---

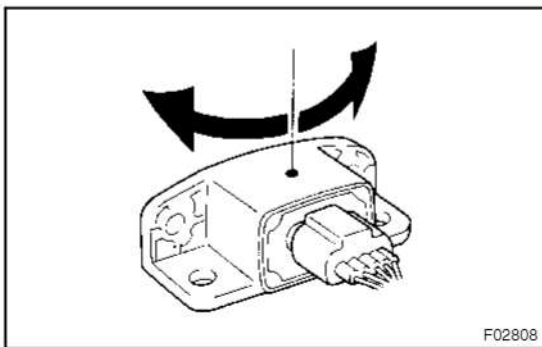

PREPARATION:

- Remove the 2 bolts and yaw rate sensor with connector still connected.
- Connect the hand-held tester to the DLC3.
- Turn the ignition switch ON and push the hand-held tester main switch ON.
- Select the DATALIST mode on the hand-held tester.

CHECK:

Check that the yaw rate value of the yaw rate sensor displayed on the hand-held tester is changing; Place the yaw rate sensor vertically to the ground and turn the sensor pivoted on its center.

OK:

Yaw rate value must be changing.

OK	Go to step 5.
-----------	----------------------

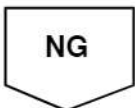

- 2 Check whether continuity exists between terminal YD of yaw rate sensor and terminal YD of ABS & BA & TRC & VSC ECU (See page IN-35).

NG

Repair or replace harness or connector.

OK

- 3 Check voltage between terminals YD and GND of ABS & BA & TRC & VSC ECU.

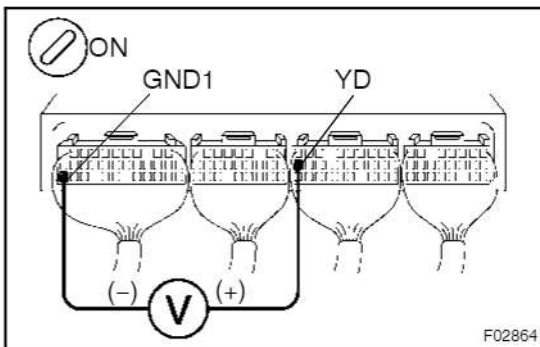
**PREPARATION:**

Remove ABS & BA & TRC & VSC ECU with connector still connected.

CHECK:

- Turn the ignition switch ON.
- Measure voltage between terminals YD and GND of ABS & BA & TRC & VSC ECU.

OK:

Voltage: 4.5 – 5.3 V

NG

Replace yaw rate sensor.

OK

Check and replace ABS & BA & TRC & VSC ECU.

4 Check yaw rate sensor.

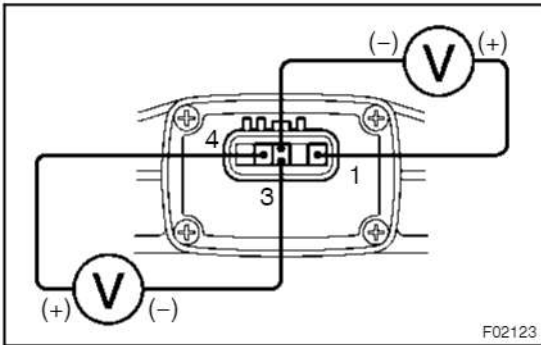

CHECK:

- (a) Turn the ignition switch ON.
- (b) Measure voltage between terminals 1 and 3, 3 and 4 of the yaw rate sensor with connector still connected.

OK:

Terminals 1 and 3 (YAW - GYAW)	Approx. 2.5 V
Terminals 3 and 4 (GYAW - YD)	Approx. 4.5 V - 5.3 V

NG Replace yaw rate sensor.

OK

5 Check for open and short circuit in harness and connector between yaw rate sensor and ABS & BA & TRC & VSC ECU (See page IN-35).

NG Repair or replace harness or connector.

OK

Check and replace ABS & BA & TRC & VSC ECU.

DTC	C1237 / 37	Tires of Different Size
------------	-------------------	--------------------------------

CIRCUIT DESCRIPTION

DTC No.	DTC Detecting Condition	Trouble Area
C1237 / 37	Driving at more than 30 km/h (19 mph) for more than 20 seconds with 1 or 2 tires of different size for 3 times continuously.	Tire size

INSPECTION PROCEDURE

1	Check tire size.
----------	-------------------------

NG**Replace tires so that all 4 tires are of the same size.****OK****Check and replace ABS & BA & TRC & VSC ECU.**

DTC	C1241 / 41	IG Power Source Circuit
------------	-------------------	--------------------------------

CIRCUIT DESCRIPTION

DTC No.	DTC Detecting Condition	Trouble Area
C1241 / 41	Detection of any of conditions 1. through 4.: 1. Vehicle speed is 3 km/h (1.9 mph) or more and voltage of ECU terminal IG remains at below 9.5 V for more than 10 sec. 2. While the condition that the solenoid relay is ON continues, ECU terminal IG1 voltage becomes 9.5 V or less, and the condition that the contact point of the solenoid relay is OFF continues for 0.2 sec. or more. 3. The condition that ECU terminal IG1 voltage is more than 17.0 V continues for 1.2 sec. or more. 4. While the solenoid relay outputs ON signal, ECU terminal IG1 voltage becomes more than 17.0 V, and the condition that the contact point of the solenoid relay is OFF continues for 0.2 sec. or more.	<ul style="list-style-type: none"> • Battery • IC regulator • Power source circuit

Fail safe function:

If trouble occurs in the power source circuit, the ECU cuts off current to the ABS solenoid relay and prohibits ABS & BA & TRC & VSC controls and the brake system becomes normal.

WIRING DIAGRAM

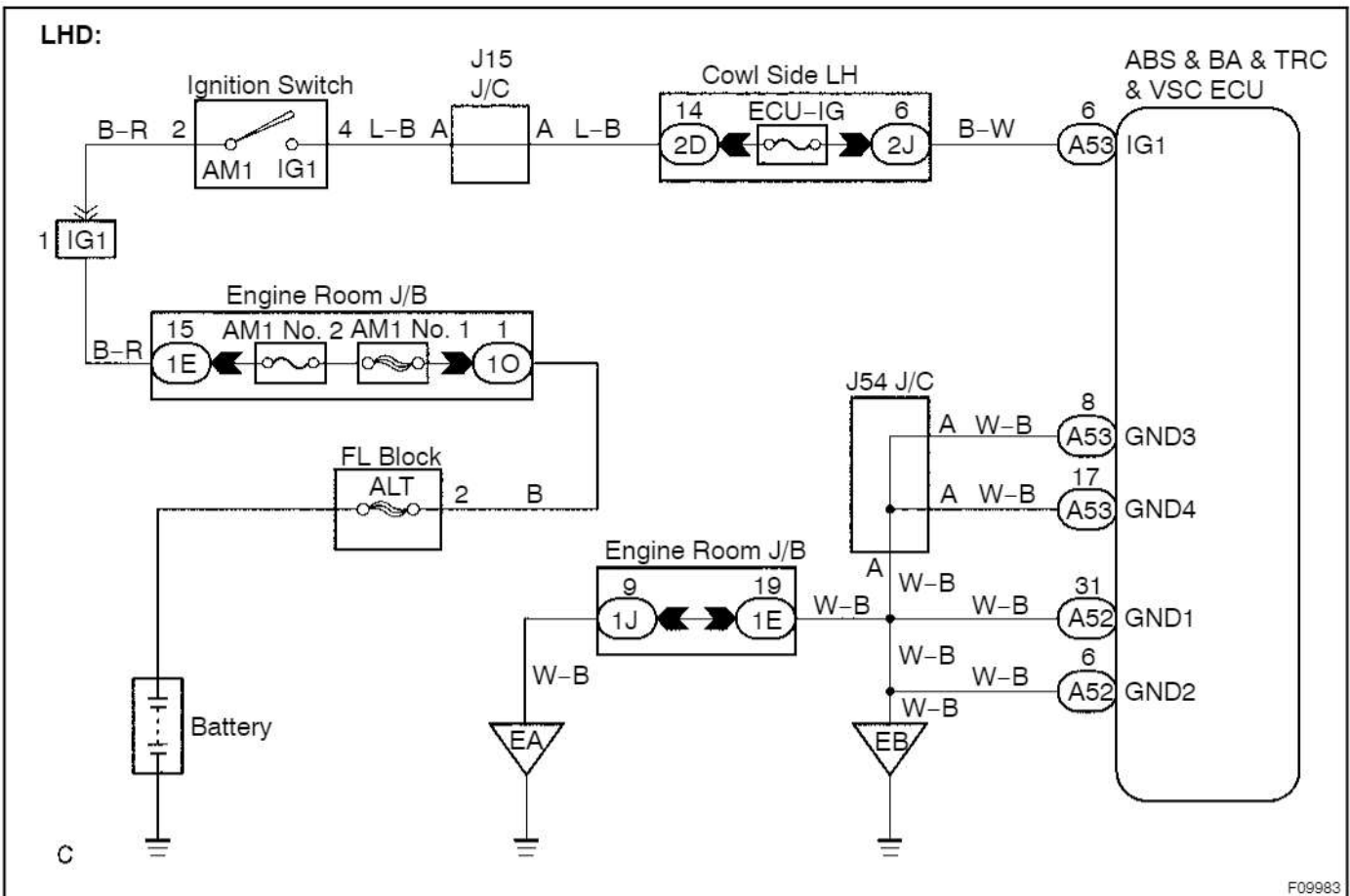

F09983

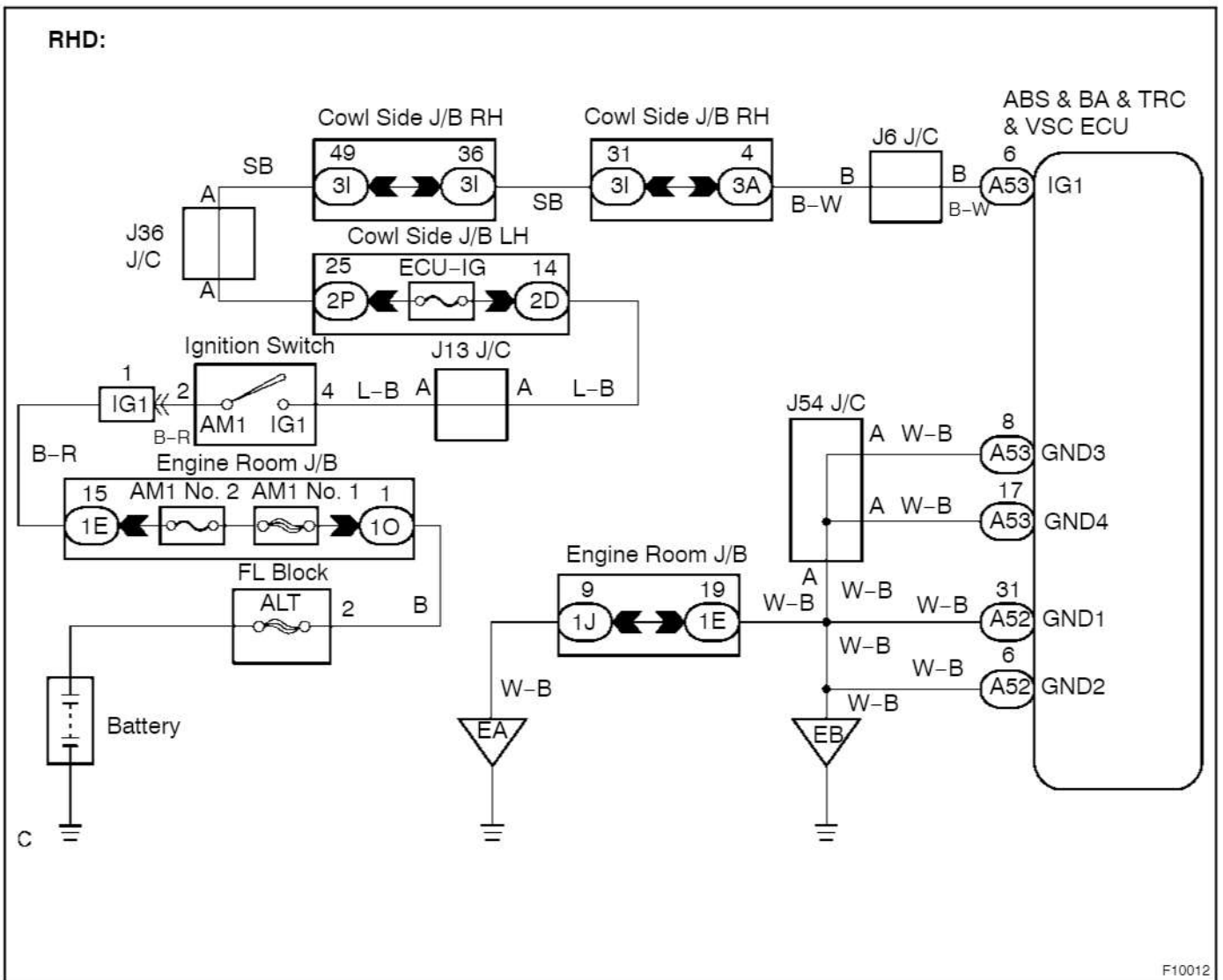

F10012

cardiagn.com

INSPECTION PROCEDURE

1	Check battery voltage.
---	------------------------

OK:

Voltage: 10 – 14 V

NG	Check and repair the charging system.
----	---------------------------------------

OK

2	Check voltage of the ECU IG power source.
---	---

In case of using the hand-held tester:

PREPARATION:

- (a) Connect the hand-held tester to the DLC3.
- (b) Turn the ignition switch ON and push the hand-held tester main switch ON.
- (c) Select the DATALIST mode on the hand-held tester.

CHECK:

Check the voltage condition output from the ECU displayed on the hand-held tester.

OK:

"Normal" is displayed.

In case of not using the hand-held tester:

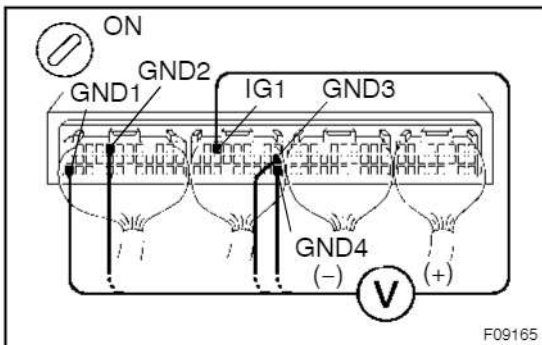

PREPARATION:

Remove ABS & BA & TRC & VSC ECU with connectors still connected.

CHECK:

- (a) Turn the ignition switch ON.
- (b) Measure voltage between terminals IG1 and GND of ABS & BA & TRC & VSC ECU connector.

OK:

Voltage: 10 – 14 V

OK	Turn ignition switch OFF, check and replace ABS & BA & TRC & VSC ECU.
----	---

NG

3 Check continuity between terminal GND of ABS & BA & TRC & VSC ECU connector and body ground.

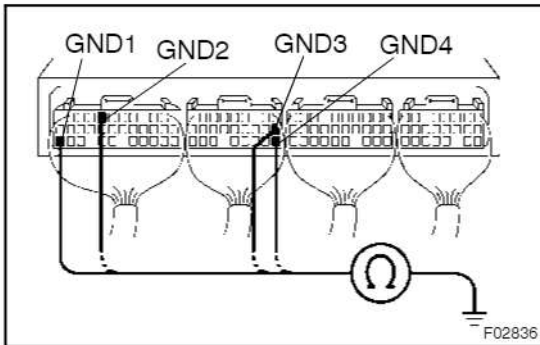
**CHECK:**

Measure resistance between terminal GND of ABS & BA & TRC & VSC ECU connector and body ground.

OK:

Resistance: 1 Ω or less

NG

Repair or replace harness or connector.

OK

4 Check ECU-IG fuse.

Cowl Side J/B LH:

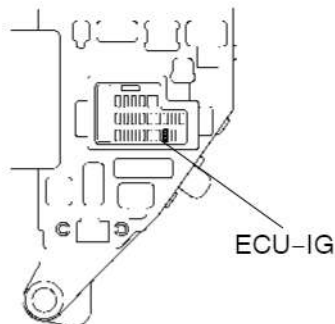

F04448

PREPARATION:

Remove ECU-IG fuse from cowl side J/B LH.

CHECK:

Check continuity of ECU-IG fuse.

OK:

Continuity

NG

Check for short circuit in all the harness and components connected to ECU-IG fuse (See attached wiring diagram).

OK

Check for open circuit in harness and connector between ABS & BA & TRC & VSC ECU and battery (See page IN-35).

DTC	C1242 / 42	IG2 Power Source Circuit
------------	-------------------	---------------------------------

CIRCUIT DESCRIPTION

DTC No.	DTC Detecting Condition	Trouble Area
C1242 / 42	With the vehicle running, open circuit in IG2 is detected for more than 7 sec.	<ul style="list-style-type: none"> • Battery • IC regulator • Power source circuit

Fail safe function:

If trouble occurs in the power source circuit, the ECU cuts off current to the ABS solenoid relay and prohibits ABS & BA & TRC & VSC controls and the brake system becomes normal.

WIRING DIAGRAM

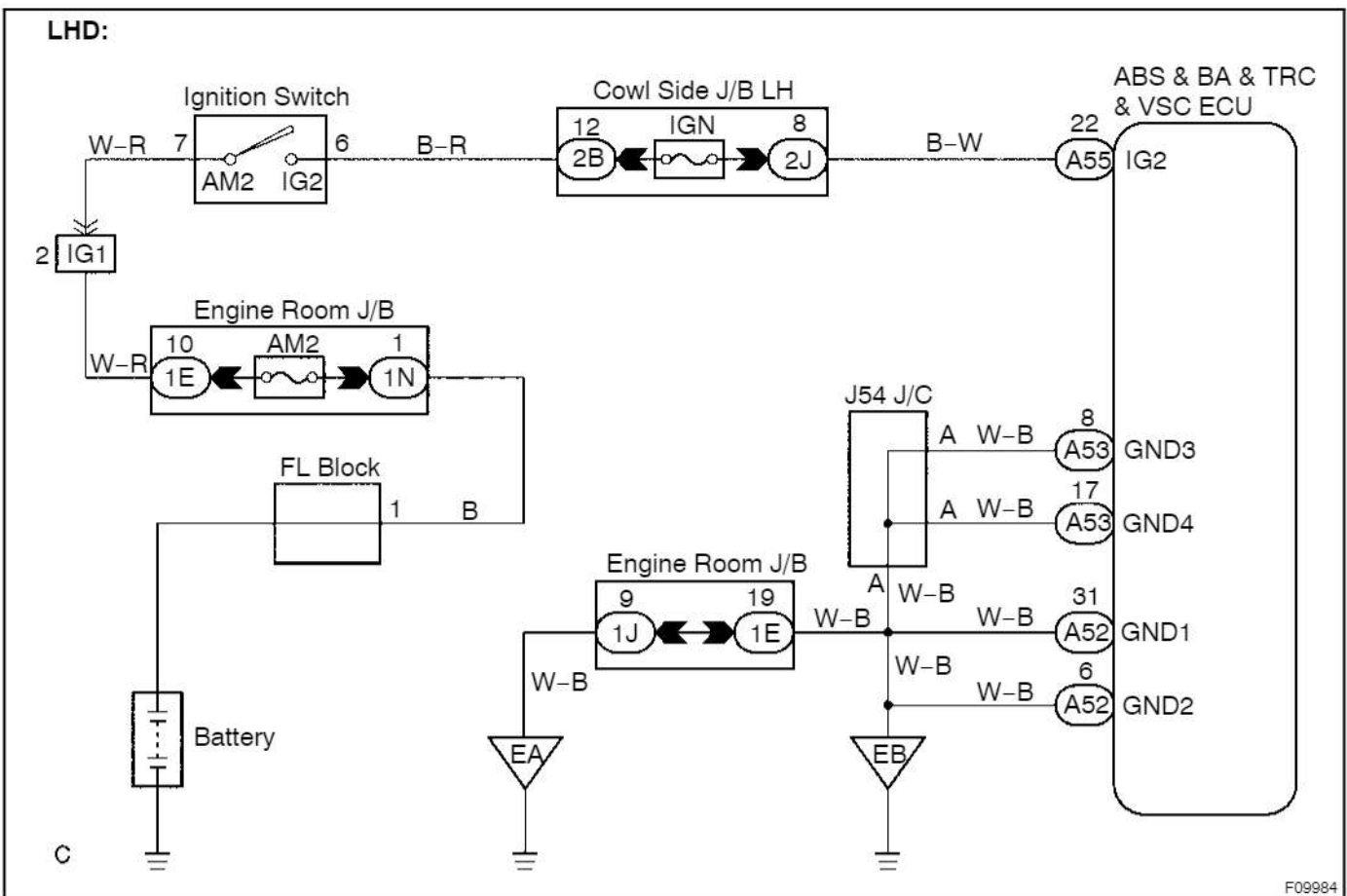

F09984

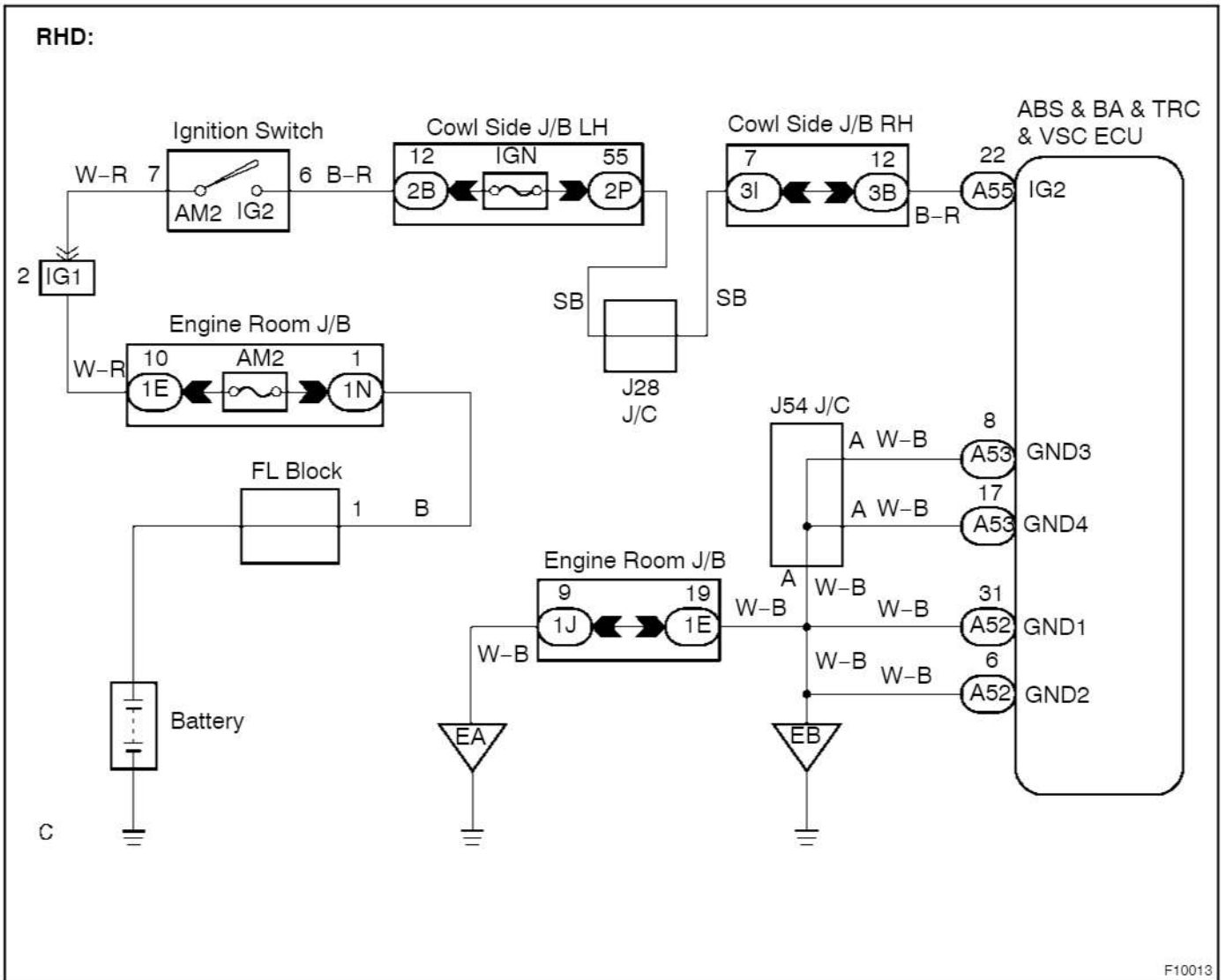

INSPECTION PROCEDURE

1	Check battery voltage.
---	------------------------

OK:

Voltage: 10 - 14 V

NG	Check and repair the charging system.
----	---------------------------------------

OK

2	Check voltage of the ECU IG power source.
---	---

In case of using the hand-held tester:

PREPARATION:

- (a) Connect the hand-held tester to the DLC3.
- (b) Turn the ignition switch ON and push the hand-held tester main switch ON.
- (c) Select the DATALIST mode on the hand-held tester.

CHECK:

Check the voltage condition output from the ECU displayed on the hand-held tester.

OK:

"Normal" is displayed.

In case of not using the hand-held tester:

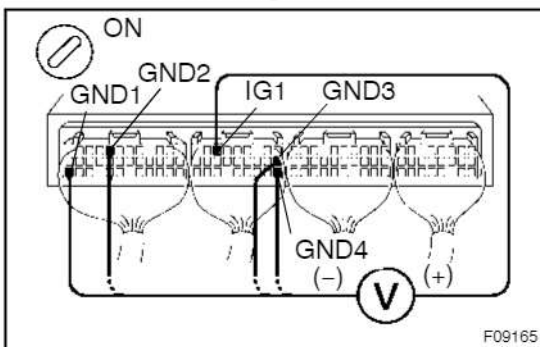

PREPARATION:

Remove ABS & BA & TRC & VSC ECU with connectors still connected.

CHECK:

- (a) Turn the ignition switch ON.
- (b) Measure voltage between terminals IG2 and GND of ABS & BA & TRC & VSC ECU connector.

OK:

Voltage: 10 - 14 V

OK	Turn ignition switch OFF, check and replace ABS & BA & TRC & VSC ECU.
----	---

NG

3 Check continuity between terminal GND of ABS & BA & TRC & VSC ECU connector and body ground.

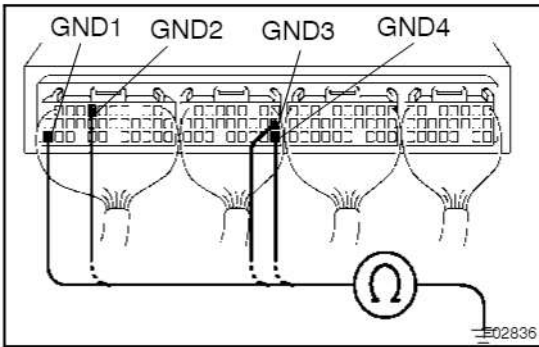
**CHECK:**

Measure resistance between terminal GND of ABS & BA & TRC & VSC ECU connector and body ground.

OK:

Resistance: 1 Ω or less

NG

Repair or replace harness or connector.

OK

Check for open circuit in harness and connector between ABS & BA & TRC & VSC ECU and battery (See page IN-35).

DTC	C1243 / 43, C1245 / 45	Malfunction in Deceleration Sensor
------------	-------------------------------	---

CIRCUIT DESCRIPTION

DTC No.	DTC Detecting Condition	Trouble Area
C1243 / 43	While vehicle speed becomes 0 km/h (0 mph) from 30 km/h (18 mph), and the condition that GL1 and GL2 signals of ECU terminals did not change 40 mV or less continued in a sequence 16 times.	<ul style="list-style-type: none"> • Deceleration sensor • Wire harness for deceleration sensor system
C1245 / 45	At the vehicle speed of 30 km/h (18 mph) or more, and the condition that the difference between acceleration and deceleration values of computation from deceleration sensor and vehicle speed becomes more than 0.35 G continues for 60 sec. or more.	

Fail safe function:

If trouble occurs in the deceleration sensor circuit, the ECU cuts off current to the ABS solenoid relay and prohibits ABS & BA & TRC & VSC controls and the brake system becomes normal.

INSPECTION PROCEDURE

HINT:

Start the inspection from step1 in case of using the hand-held tester and start from step 2 in case of not using the hand-held tester.

1	Check output value of the deceleration sensor.
----------	---

PREPARATION:

- (a) Connect the hand-held tester to the DLC3.
- (b) Turn the ignition switch ON and push the hand-held tester main switch ON.
- (c) Select the DATALIST mode on the hand-held tester.

CHECK:

Check that the deceleration value of the deceleration sensor displayed on the hand-held tester is changing when tilting the vehicle.

OK:

Deceleration value must be changing.



2	Check deceleration sensor (See page DI-4).
----------	---



OK

3 Check for open or short circuit in harness and connector between deceleration sensor and ABS & BA & TRC & VSC ECU ([See page IN-35](#)).

NG

Repair or replace harness or connector.

OK

Check and replace ABS & BA & TRC & VSC ECU.

DTC	C1244 / 44	Deceleration Sensor Circuit
------------	-------------------	------------------------------------

CIRCUIT DESCRIPTION

This sensor detects deceleration on the vehicle. The sensor signal is used in ABS & BA & TRC & VSC control. If the sensor functions abnormally, the ABS warning light comes on.

DTC No.	DTC Detecting Condition	Trouble Area
C1244 / 44	Either of the following 1., 2., 3. or 4. is detected: 1. The condition that ECU terminals GL1 and GL2 values are -1.5 G or less or 1.5 G or more continues for 1.2 sec. or more. 2. The condition that the deceleration sensor terminal VGS voltage is 4.4 V or less or 5.6 V or more continues for 1.2 sec. or more. 3. At the vehicle speed of 0 km/h (0 mph), after the difference of output value between deceleration sensor terminals GL1 and GL2 becomes 0.6 G or more, and the condition that does not become 0.4 G or less continues for 60 sec. or more. 4. Deceleration sensor signal momentary open occurs for 7 times or more.	<ul style="list-style-type: none"> • Deceleration sensor • Deceleration sensor circuit

Fail safe function:

If trouble occurs in the deceleration sensor circuit, the ECU cuts off current to the ABS solenoid relay and prohibits ABS & BA & TRC & VSC controls and the brake system becomes normal.

WIRING DIAGRAM

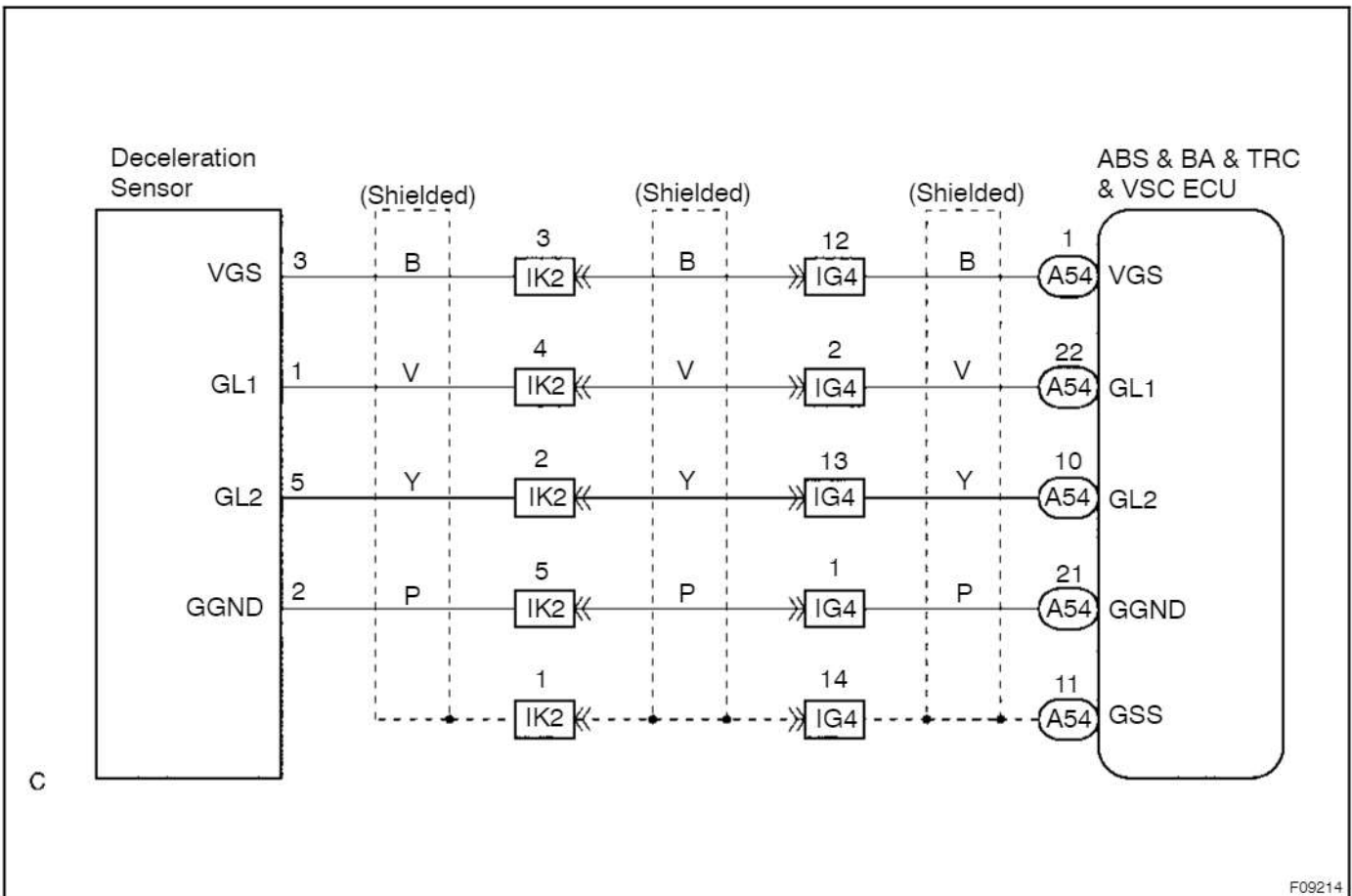

INSPECTION PROCEDURE

- | | |
|----------|---|
| 1 | Check for open and short circuit in harness and connector between deceleration sensor and ABS & BA & TRC & VSC ECU (See page IN-35). |
|----------|---|

NG**Repair or replace harness or connector.****OK**

- | | |
|----------|---|
| 2 | Check deceleration sensor (See page DI-4). |
|----------|---|

NG**Replace deceleration sensor.****OK****Check and replace ABS & BA & TRC & VSC ECU.**

DTC	C1246 / 46	Master Cylinder Pressure Sensor Circuit
------------	-------------------	--

CIRCUIT DESCRIPTION

DTC No.	DTC Detecting Condition	Trouble Area
C1246 / 46	Either of the following 1., 2., 3., 4. or 5. is detected: 1. At the vehicle speed of 7 km/h (4 mph) or more, ECU terminal PMC voltage becomes more than 0.86 V and the condition that 0.01 V or less does not change continues for 30 sec. 2. Interference occurs to ECU terminal PMC 7 times or more for 5 sec. 3. ECU terminal STP is OFF, and the condition that terminal PMC voltage becomes more than 0.86 V or less than 0.3 V continues for 5 sec. or more. 4. The condition that ECU terminal IG1 voltage is 9.5 V to 17.0 V, and terminal VCM voltage other than the range from 4.4 V to 5.6 V continues for 1.2 sec. or more. 5. The condition that ECU terminal VCM voltage is 4.4 V to 5.6 V, and terminal PMC voltage other than the range from 0.14 V to 4.85 V continues for 1.2 sec. or more.	<ul style="list-style-type: none"> • Master cylinder pressure sensor • Master cylinder pressure sensor circuit

Fail safe function:

If trouble occurs in the master cylinder pressure sensor circuit, the ECU cuts off current to the ABS solenoid relay and prohibits ABS & BA & TRC & VSC controls and the brake system becomes normal.

WIRING DIAGRAM

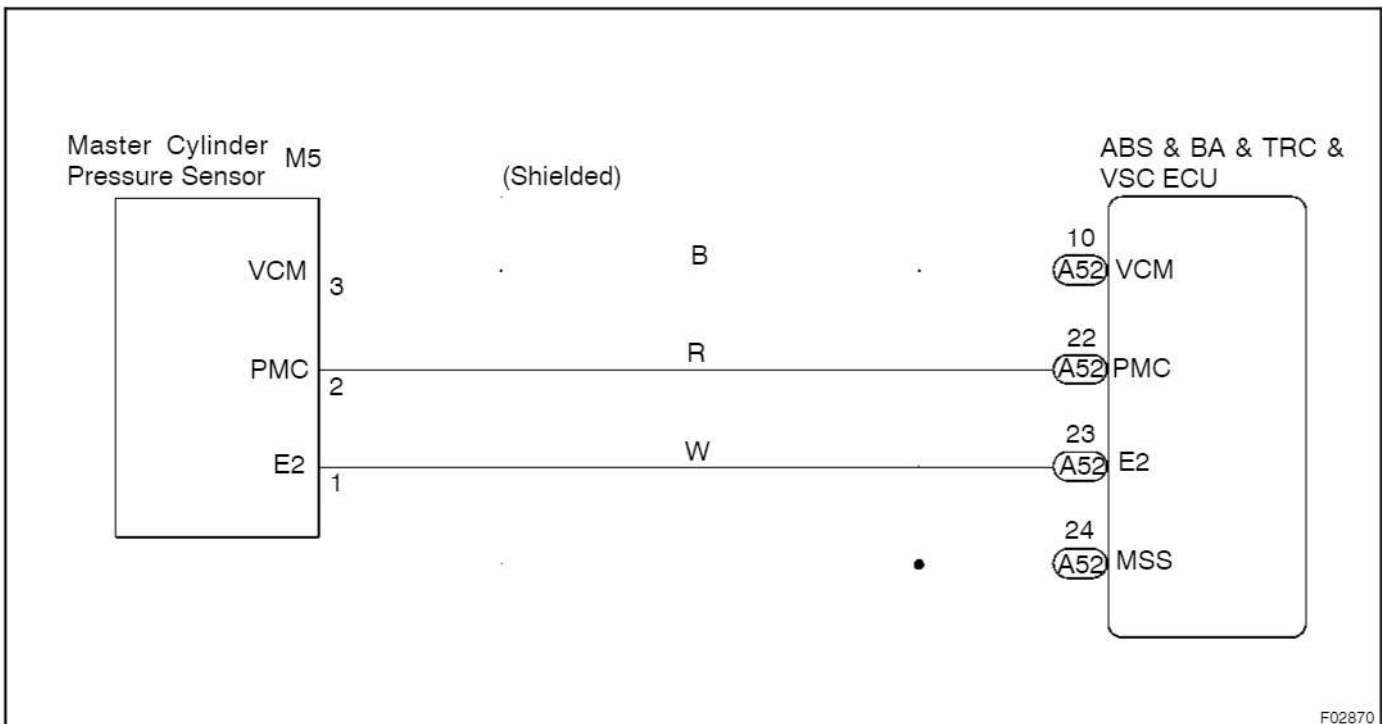

F02870

INSPECTION PROCEDURE**HINT:**

Start the inspection from step 1 in case of using the hand-held tester and start from step 2 in case of not using the hand-held tester.

1 Check output value of the master cylinder pressure sensor.

PREPARATION:

- (a) Connect the hand-held tester to the DLC3.
- (b) Turn the ignition switch ON and push the hand-held tester main switch ON.
- (c) Select the DATALIST mode on the hand-held tester.

CHECK:

Check that the brake fluid pressure value of the master cylinder pressure sensor displayed on the hand-held tester is changing when depressing the brake pedal.

OK:

Brake fluid pressure value must be changing.

OK

Go to step 4.

NG

2 Check master cylinder pressure sensor.

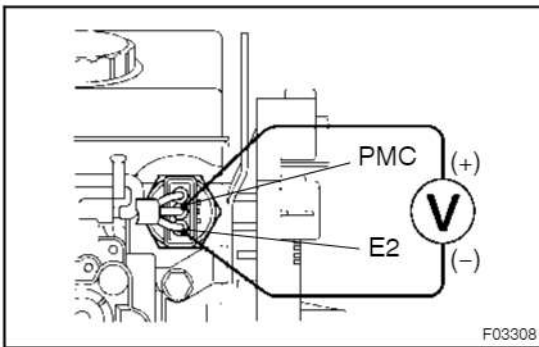
**PREPARATION:**

- (a) Install LSPV gauge to the front caliper bleeder plug portion, and bleed LSPV gauge.
SST 09709-29018
- (b) Remove air cleaner inlet and battery clamp cover.

CHECK:

Start the engine and depress the brake pedal, then check the relation between the fluid pressure and voltage of PMC and E2 terminals of the master cylinder pressure sensor with connector still connected.

OK:

Front brake caliper fluid pressure	Voltage
0 kPa (0 Kgf/cm ² , 0 psi)	0.37 – 0.63 V
5,883 kPa (60 kgf/cm ² , 853 psi)	1.57 – 1.83 V
11,768 kPa (120 kgf/cm ² , 1,706 psi)	2.77 – 3.03 V

HINT:

Voltage of between terminals VCM and E2: 4.7 – 5.3 V

NG

Replace master cylinder pressure sensor.

OK

3 Check for open and short circuit in harness and connector between master cylinder pressure sensor and ABS & BA & TRC & VSC ECU (See page IN-35).

NG Repair or replace harness or connector.

OK

4 Check whether or not the ECU terminal STP input voltage is changed when the stop light switch is turned on and off.

NO Check the stop light switch circuit (See page DI-82).

YES

Check and replace ABS & BA & TRC & VSC ECU.

cardiagn.com

DTC	C1249 / 49	Stop Light Switch Circuit
------------	-------------------	----------------------------------

CIRCUIT DESCRIPTION

DTC No.	DTC Detecting Condition	Trouble Area
C1249 / 49	ECU terminal IG1 voltage is 9.5 to 17.2 V and ABS is in non-operation, the open circuit in stop light switch circuit continues for 0.3 sec. or more.	Stop light switch circuit

WIRING DIAGRAM

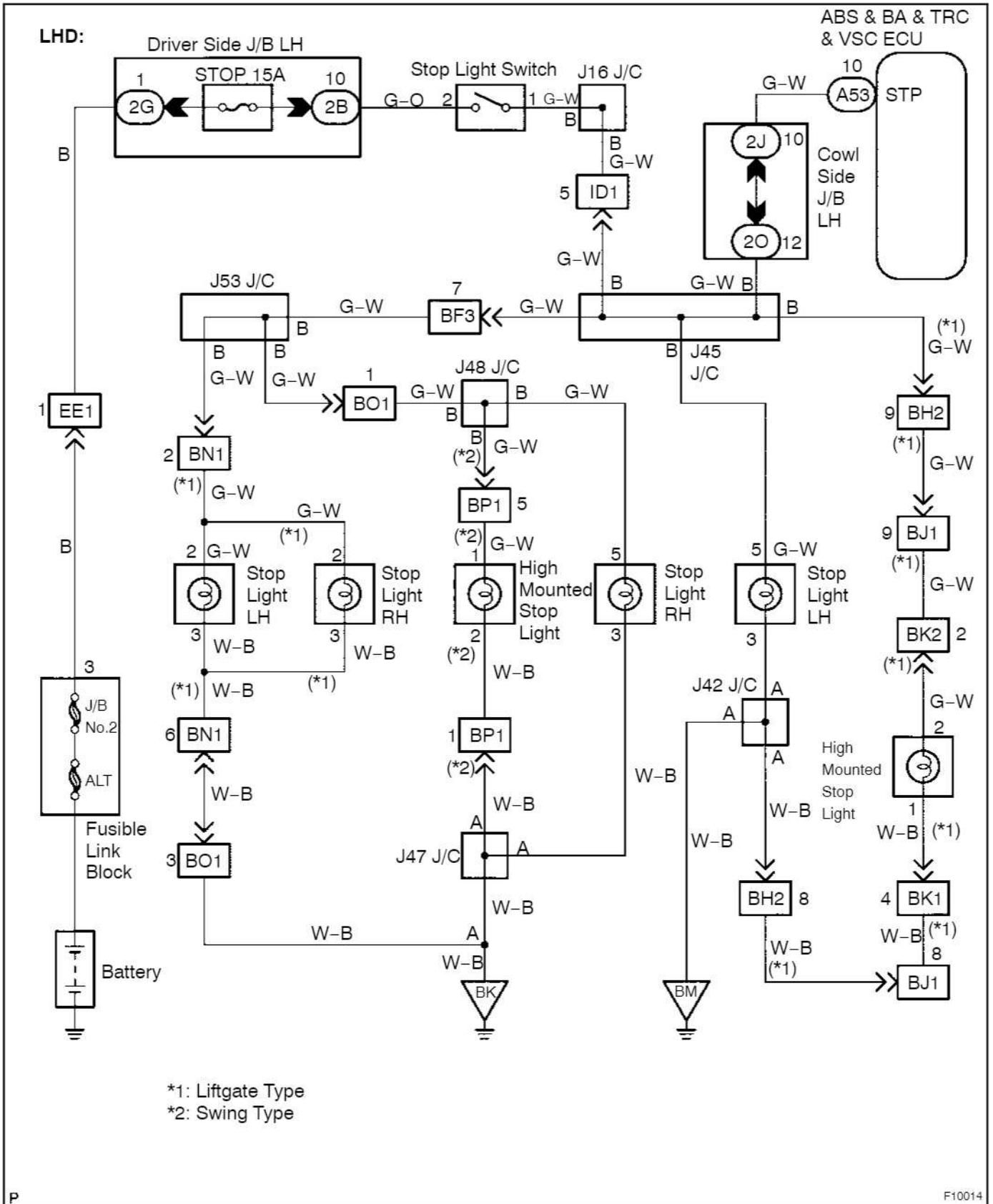

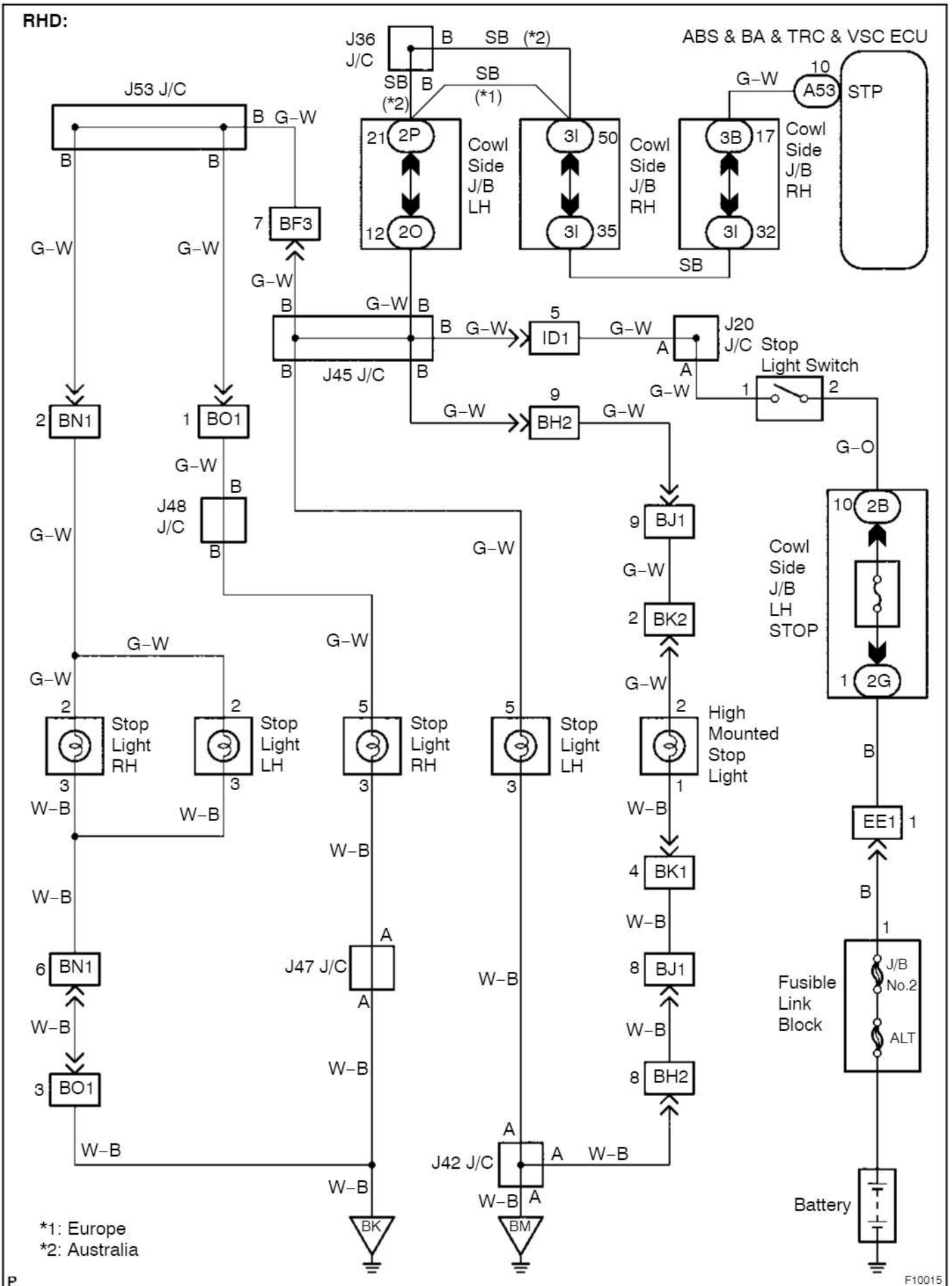

cardiagn.com

INSPECTION PROCEDURE

1 Check operation of the stop light switch.

CHECK:

Check that the stop light lights up when brake pedal is depressed and turns OFF when the brake pedal is released.

OK

Go to step 3.

NG

2 Check stop light circuit (See Pub. No. RM616E on page BE-58).

NG

Repair or replace stop light circuit.

OK

3 Check voltage between terminal STP of ABS & BA & TRC & VSC ECU and body ground.

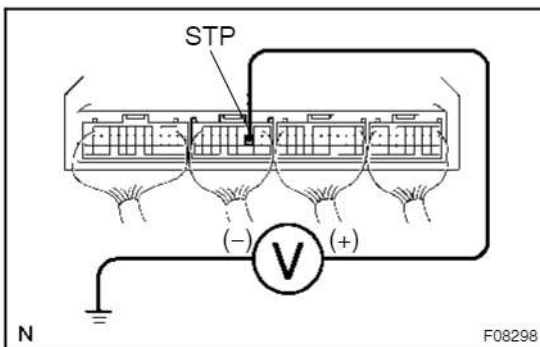

PREPARATION:

Remove ABS & BA & TRC & VSC ECU with connectors still connected.

CHECK:

Measure voltage between terminal STP of ABS & BA & TRC & VSC ECU and body ground when brake pedal is depressed.

OK:

Voltage: 10 - 14 V

OK

Proceed to next circuit inspection shown in problem symptoms chart (See page DI-23).

NG

4

Check for open circuit in harness and connector between ABS & BA & TRC & VSC ECU and stop light switch (See page IN-35).

NG

Repair or replace harness or connector.

OK

Check and replace ABS & BA & TRC & VSC ECU.

DTC	C1251 / 51	Hydraulic Brake Booster Pump Motor Malfunction
------------	-------------------	---

CIRCUIT DESCRIPTION

DTC No.	DTC Detecting Condition	Trouble Area
C1251 / 51	Either of the following 1. or 2. is detected: 1. After turning the ignition switch ON, the current of more than 30 A flows to the motor for more than 1 sec. 2. After turning the ignition switch ON, less than 7 A change in current is detected more than 3 times in a low when the motor is ON.	Hydraulic brake booster pump motor

Fail safe function:

If trouble occurs in the pump motor, the ECU cuts off current to the ABS solenoid relay and prohibits ABS & BA & TRC & VSC controls.

WIRING DIAGRAM

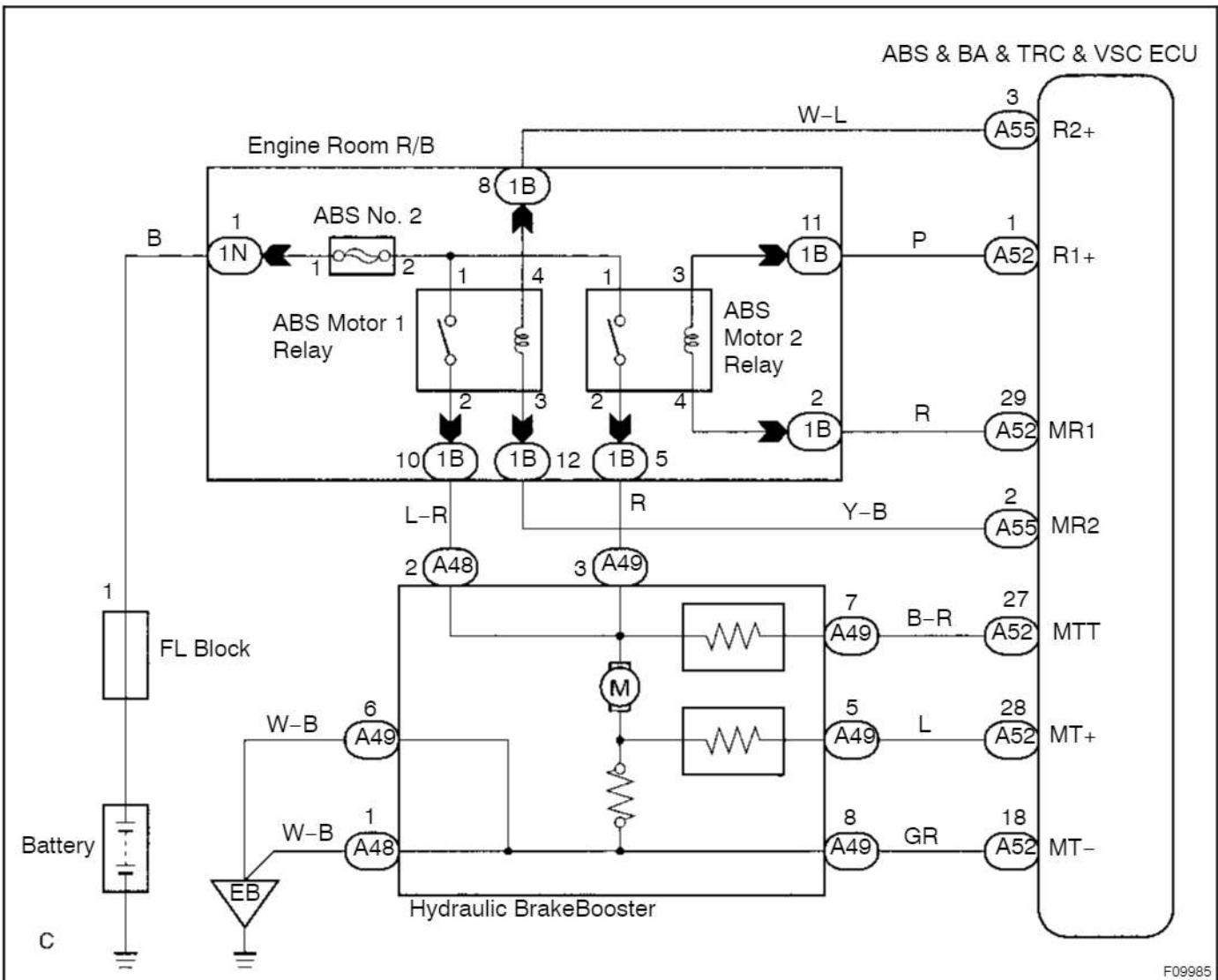

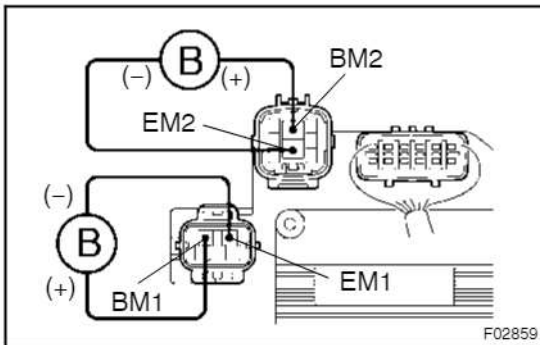
INSPECTION PROCEDURE**1 Check operation of hydraulic brake booster pump motor.****PREPARATION:**

Disconnect the 2 connectors from the hydraulic brake booster.

CHECK:

Connect battery positive \oplus lead to BM1 or BM2 terminal and battery negative \ominus lead to EM1 or EM2 terminal of the hydraulic brake booster (pump motor) connector.

OK:

The operation sound of the pump motor should be heard.

NG

Go to step 4.

OK

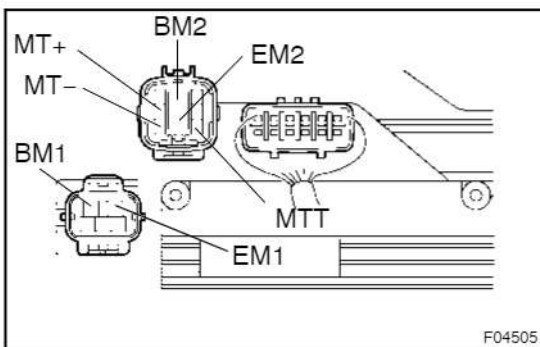
2 Check hydraulic brake booster resistance.**PREPARATION:**

Disconnect the 2 connectors from the hydraulic brake booster.

CHECK:

Check resistance between terminals MT+ and MT-, BM1 and MT-, BM2 and MTT, EM1 and MT+, EM2 and MT+ of the hydraulic brake booster connector.

OK:

30 - 36 Ω

NG

Replace the hydraulic brake booster assembly.

OK

3 Check for open circuit in harness and connector between hydraulic brake booster (MT+, MT-) and ABS & BA & TRC & VSC ECU (See page IN-35).

NG

Repair or replace harness or connector.

OK

Check and replace ABS & BA & TRC & VSC ECU.

4 Check for open or short circuit in harness and connector between hydraulic brake booster pump motor and hydraulic brake booster (See page IN-35).

NG

Replace wire harness.

OK

5 Check hydraulic brake booster pump motor (See page BR-32).

NG

Replace hydraulic brake booster pump motor.

OK

Replace hydraulic brake booster.

DTC	C1252 / 52	Hydraulic Brake Booster Pump Motor ON Time Abnormally Long
------------	-------------------	---

CIRCUIT DESCRIPTION

DTC No.	DTC Detecting Condition	Trouble Area
C1252 / 52	After the ignition switch has been turned ON, when the power is supplied to the pump motor for more than 5 minutes.	<ul style="list-style-type: none"> Hydraulic brake booster pump motor Hydraulic brake booster pump motor circuit Pressure switch (PH or PL)

Fail safe function:

If trouble occurs in the pump motor, the ECU cuts off current to the ABS solenoid relay and prohibits ABS & BA & TRC & VSC controls.

WIRING DIAGRAM

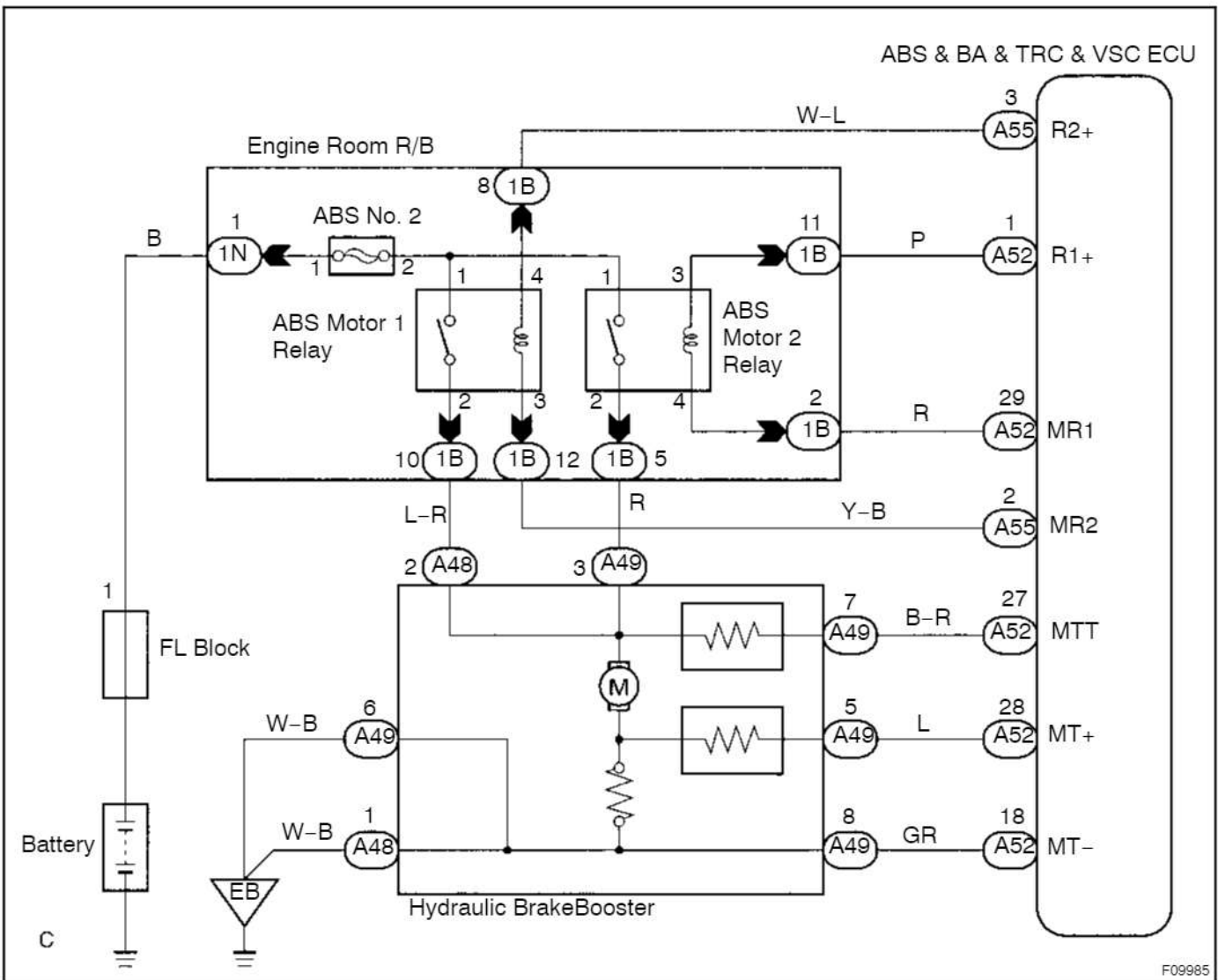

F09985

INSPECTION PROCEDURE

1 Check operation of hydraulic brake booster pump motor.

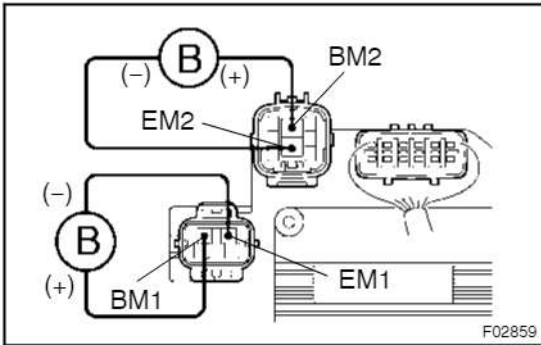

PREPARATION:

Disconnect the 2 connectors from the hydraulic brake booster.

CHECK:

Connect battery positive ⊕ lead to BM1 or BM2 terminal and battery negative ⊖ lead to EM1 or EM2 terminal of the hydraulic brake booster (pump motor) connector.

OK:

The operation sound of the pump motor should be heard.

NG

Go to step 9.

OK

2 Check for short circuit (to B+) in harness and connector between BM1 or BM2 of hydraulic brake booster and ABS motor 1 or ABS motor 2 relay (See page IN-35).

NG

Repair or replace harness or connector.

OK

3 Check for short circuit (to B+) in harness and connector between MTT of hydraulic brake booster and ABS & BA & TRC & VSC ECU (See page IN-35).

NG

Repair or replace harness or connector.

OK

4	Check pressure switch (PH).
---	------------------------------------

In case of using the hand-held tester.

PREPARATION:

- (a) Connect the hand-held tester to the DLC3.
- (b) Turn the ignition switch ON and push the hand-held tester main switch ON.
- (c) Select the DATALIST mode on the hand-held tester.

CHECK:

Depress the brake pedal more than 40 times with the ignition switch OFF then turn the ignition switch ON and check the pressure switch (PH) condition.

HINT:

When a pressure in power supply system is released, reaction force becomes light and stroke becomes longer.

OK:

"OFF" turns to "ON".

HINT:

OFF: Low pressure

ON: High pressure

In case of not using the hand-held tester.

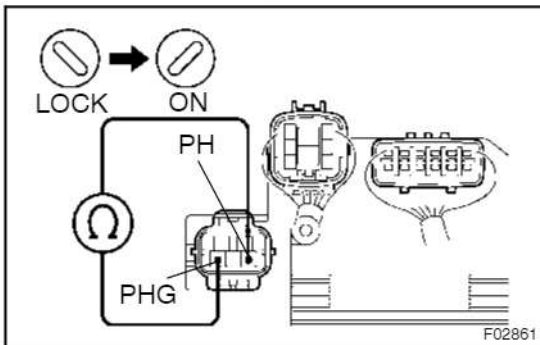

PREPARATION:

- (a) Disconnect the connector (5P) from the hydraulic brake booster.
- (b) With the ignition switch OFF, depress the brake pedal more than 40 times to decrease the accumulator pressure.

HINT:

When a pressure in power supply system is released, reaction force becomes light and stroke becomes longer.

CHECK:

Measure resistance between terminals PH and PHG of hydraulic brake booster connector.

OK:

Resistance: 1.0 k Ω

PREPARATION:

- (a) Connect the connector (5P) to the hydraulic brake booster.
- (b) Disconnect the connector (5P) after ignition switch has been ON and the pump motor has stopped.

CHECK:

Measure resistance between terminals PH and PHG of hydraulic brake booster connector.

OK:

Resistance: 0 Ω

HINT:

After inspection, connect the connector and clear the DTC (See page DI-4).

NG

Replace hydraulic brake booster assembly.

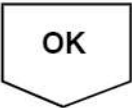

5	Check pressure switch (PL).
----------	------------------------------------

In case of using hand-held tester:

PREPARATION:

- (a) Connect the hand-held tester to the DLC3.
- (b) Turn the ignition switch ON and push the hand-held tester main switch ON.
- (c) Select the DATALIST mode on the hand-held tester.

CHECK:

Depress the brake pedal more than 40 times with the ignition switch OFF then turn the ignition switch ON and check the pressure switch (PL) condition.

HINT:

When a pressure in power supply system is released, reaction force becomes light and stroke becomes longer.

OK:

"OFF" turns to "ON".

HINT:

OFF: Low pressure

ON: High pressure

In case of not using hand-held tester:

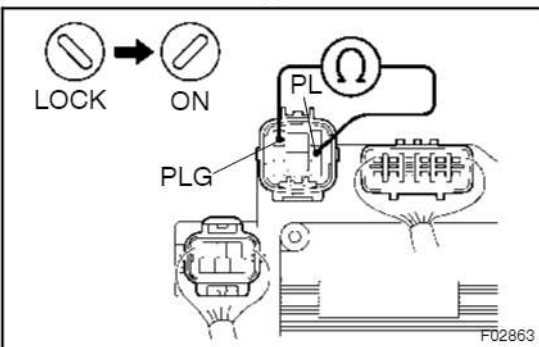

PREPARATION:

- (a) Disconnect the connector (8P) from the hydraulic brake booster.
- (b) With the ignition switch OFF, depress the brake pedal more than 40 times to decrease the accumulator pressure.

HINT:

When a pressure in power supply system is released, reaction force becomes light and stroke becomes longer.

CHECK:

Measure resistance between terminals PL and PLG of hydraulic brake booster connector.

OK:

Resistance: 5.7 kΩ

PREPARATION:

- (a) Connect the connector (8P) to the hydraulic brake booster.
- (b) Disconnect the connector (8P) after ignition switch has been ON and the pump motor has stopped.

CHECK:

Measure resistance between terminals PL and PLG of hydraulic brake booster connector.

OK:

Resistance: 1.0 kΩ

HINT:

After inspection, connect the connector and clear the DTC (See page DI-4).

NG → **Replace hydraulic brake booster assembly.**

OK

6 Check for short circuit (to B+) in harness and connector between pressure switch and ABS & BA & TRC & VSC ECU (See page IN-35).

NG → **Repair or replace harness or connector.**

OK

7 Check ABS motor 1 and ABS motor 2 relay.

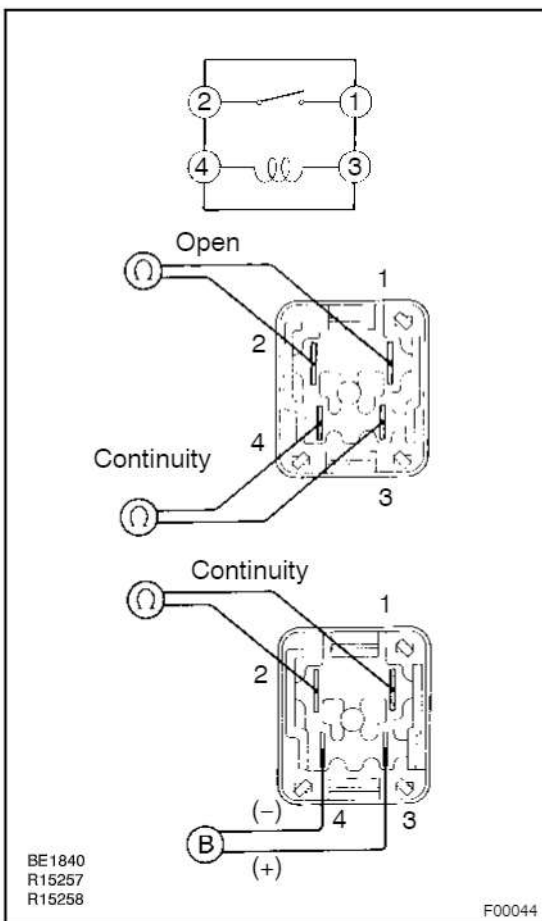

PREPARATION:

Remove ABS motor 1 and ABS motor 2 relay from engine room J/B.

CHECK:

Check continuity between each pair of terminal of motor relay.

OK:

Terminals 3 and 4	Continuity (Reference value *1)
Terminals 1 and 2	Open

*1: ABS motor 1 relay 54 Ω

ABS motor 2 relay 62 Ω

CHECK:

- (a) Apply battery voltage between terminals 3 and 4.
- (b) Check continuity between terminals.

OK:

Terminals 1 and 2	Continuity
-------------------	------------

NG → Replace ABS motor 1 or ABS motor 2 relay.

OK

8 Check for short circuit in harness and connector between ABS motor 1 or ABS motor 2 relay and ABS & BA & TRC & VSC ECU (See page IN-35).

NG → Repair or replace harness or connector.

OK

Check and replace ABS & BA & TRC & VSC ECU.

9 Check for open or short circuit in harness and connector between hydraulic brake booster pump motor and hydraulic brake booster (See page IN-35).

NG → Replace wire harness.

OK

10 Check hydraulic brake booster pump motor (See page BR-32).

NG → Replace hydraulic brake booster pump motor.

OK

Replace hydraulic brake booster.

cardiagn.com

DTC	C1253 / 53	Motor Relay Circuit
------------	-------------------	----------------------------

CIRCUIT DESCRIPTION

The ABS motor 1 and ABS motor 2 relay supplies power to the hydraulic brake booster pump motor. While the ABS & BA & TRC & VSC are activated, the ECU switches the motor relay ON and operates the hydraulic brake booster pump motor.

DTC No.	DTC Detecting Condition	Trouble Area
C1253 / 53	<p>When any of the following 1. through 4. is detected:</p> <ol style="list-style-type: none"> 1. After turning the ignition switch ON, open in the relay coil is detected for more than 1 sec. 2. When the pressure switch does not control motor driving, the status that the motor relay is always ON continues for more than 1 sec. due to short circuit. 3. When the pressure switch (PH) detects the low pressure or while the pump motor operates to increase the pressure, the status that the motor relay does not turn ON continues for more than 0.2 sec. 4. When pressure switch does not control motor driving, the status that the motor relay is always ON due to the welded contact continues for more than 2 sec. 	<ul style="list-style-type: none"> •ABS motor 1 or ABS motor 2 relay •ABS motor 1 or ABS motor 2 relay circuit •Hydraulic brake booster pump motor circuit

Fail safe function:

If trouble occurs in the ABS motor 1 and ABS motor 2 relay circuit, the ECU cuts off current to the ABS solenoid relay and prohibits ABS & BA & TRC & VSC controls.

WIRING DIAGRAM

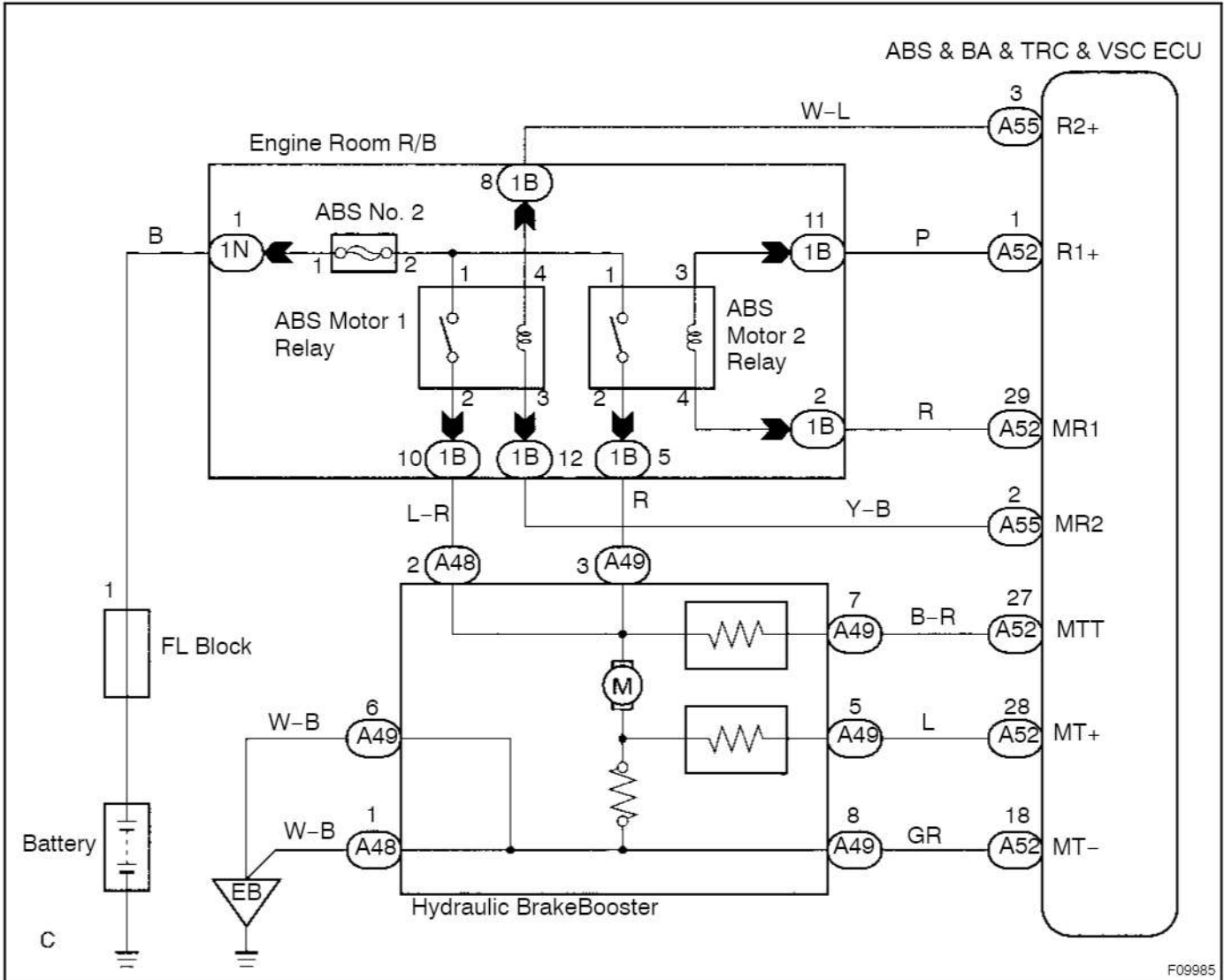

INSPECTION PROCEDURE

HINT:

Start the inspection from step 1, in case of using the hand-held tester and start from step 3, in case of not using hand-held tester.

1	Check ABS motor 1 and ABS motor 2 relay operation.
----------	---

PREPARATION:

- (a) Connect the hand-held tester to the DLC3.
- (b) Turn the ignition switch ON and push the hand-held tester main switch ON.
- (c) Select the ACTIVE TEST mode on the hand-held tester.

CHECK:

Check the operation sound of the ABS motor relays individually when operating it with the hand-held tester.

OK:

The operation sound of the ABS motor 1 and ABS motor 2 relay should be heard.

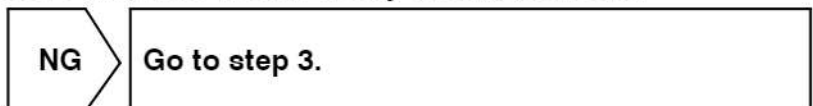

OK

- 2 Check for short circuit (to B+) in harness and connector between MTT of hydraulic brake booster and ABS & BA & TRC & VSC ECU (See page IN-35).

NG

Repair or replace harness or connector.

OK

Check and replace ABS & BA & TRC & VSC ECU.

- 3 Check voltage between terminal 1 of engine room J/B (for ABS motor 1 and ABS motor 2 relay) and body ground.

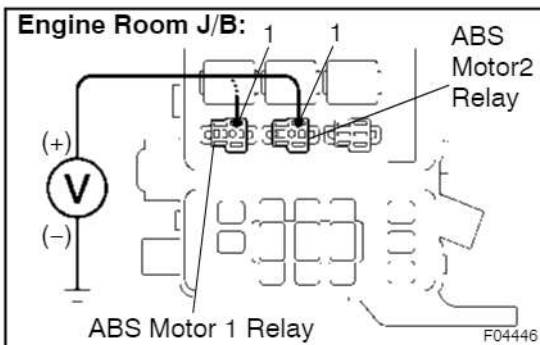
**PREPARATION:**

Remove ABS motor 1 and ABS motor 2 relay from engine room J/B.

CHECK:

Measure voltage between terminal 1 of engine room J/B (for ABS motor 1 and ABS motor 2 relay) and body ground.

OK:

Voltage: 10 - 14 V

NG

Check and repair harness or connector.

OK

4 Check ABS motor 1 and ABS motor 2 relay.

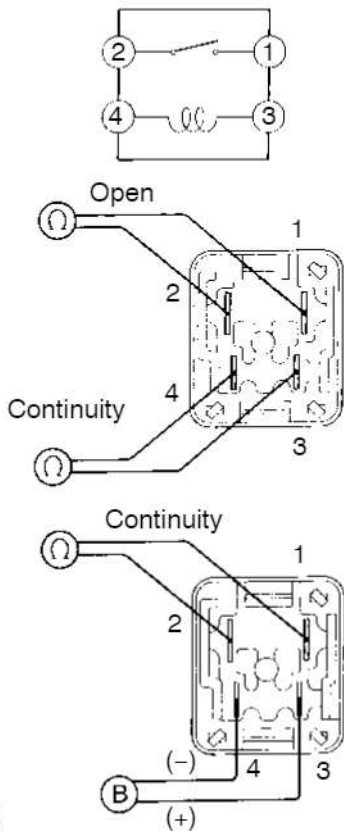

BE1840
R15257
R15258

F00044

PREPARATION:

Remove ABS motor 1 and ABS motor 2 relay from engine room J/B.

CHECK:

Check continuity between each pair of terminal of motor relay.

OK:

Terminals 3 and 4	Continuity (Reference value *1)
Terminals 1 and 2	Open

*1: ABS motor 1 relay 54 Ω

ABS motor 2 relay 62 Ω

CHECK:

- (a) Apply battery voltage between terminals 3 and 4.
- (b) Check continuity between terminals.

OK:

Terminals 1 and 2	Continuity
-------------------	------------

NG

Replace ABS motor 1 or ABS motor 2 relay.

OK

- 5 Check continuity between each terminal BM1 and BM2 and terminal MTT of ABS & BA & TRC & VSC ECU.**

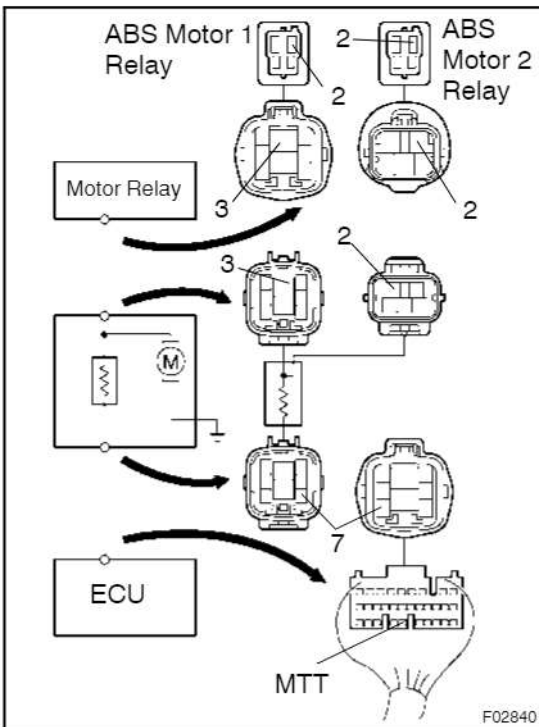
**PREPARATION:**

Disconnect the 2 connectors from the hydraulic brake booster.

CHECK:

- Check continuity between terminal BM1 of ABS motor 2 relay and terminal MTT of ABS & BA & TRC & VSC ECU.
- Check continuity between terminal BM2 of ABS motor 1 relay and terminal MTT of ABS & BA & TRC & VSC ECU.

OK:**Continuity****HINT:**

There is resistance of $33 \pm 3 \Omega$ between terminal BM1 or BM2 and MTT of the hydraulic brake booster.

NG

Repair or replace harness, connector or hydraulic brake booster.

OK

- 6 Check for open and short circuit in harness and connector between ABS motor 1 and ABS motor 2 relay and ABS & BA & TRC & VSC ECU (See page IN-35).**

NG

Repair or replace harness or connector.

OK

Check and replace ABS & BA & TRC & VSC ECU.

DTC	C1254 / 54	Pressure Switch Circuit
------------	-------------------	--------------------------------

CIRCUIT DESCRIPTION

DTC No.	DTC Detecting Condition	Trouble Area
C1254 / 54	Either of the following 1. or 2. is detected: 1. After turning the ignition switch ON, short or open circuit in pressure switch (PL) continued for more than 1 sec. 2. After turning the ignition switch ON open in pressure switch (PH) continued for more than 1 sec.	<ul style="list-style-type: none"> • Pressure switch (PH or PL) • Pressure switch circuit

WIRING DIAGRAM

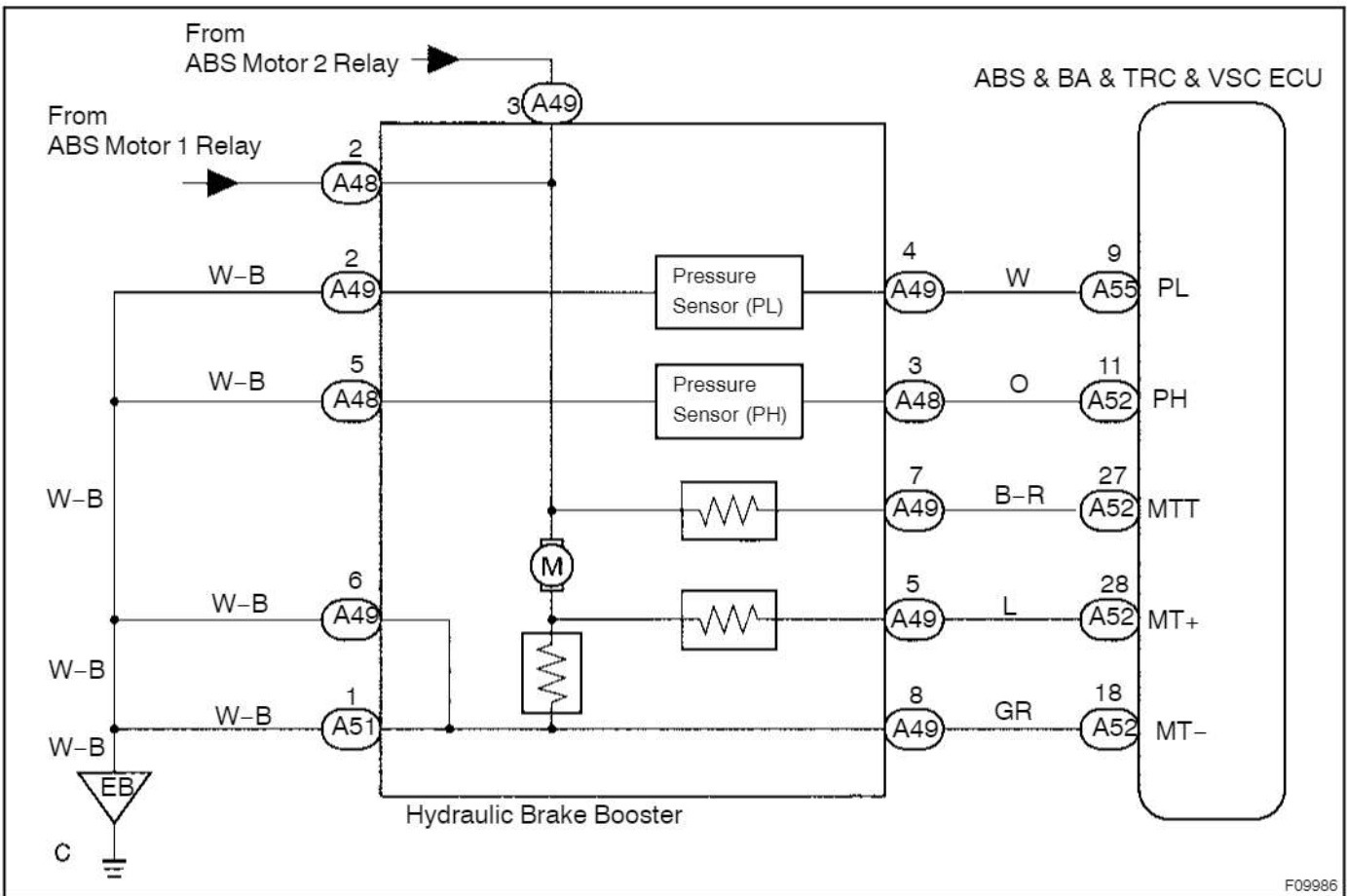

cardiagn.com

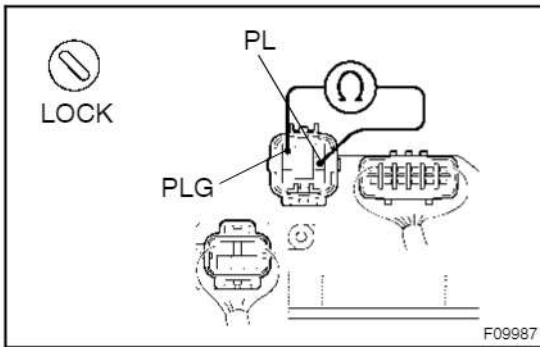
INSPECTION PROCEDURE**1 Check pressure switch (PL) resistance.****PREPARATION:**

- Disconnect the connector (8P) from the hydraulic brake booster.
- With ignition switch OFF, depress the brake pedal more than 40 times to decrease the accumulator pressure.

HINT:

When a pressure in power supply system is released, reaction force becomes light and stroke becomes longer.

CHECK:

Measure resistance between terminals PL and PLG of hydraulic brake booster connector.

OK:

Resistance: 5.1 – 6.3 k Ω

HINT:

After inspection, connect the connector and clear the DTC (See page DI-4).

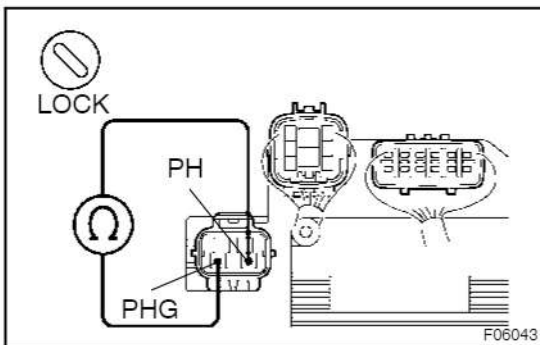
NG**Replace hydraulic brake booster assembly.****OK****2 Check pressure switch (PH) resistance.****PREPARATION:**

- Disconnect the connector (5P) from the hydraulic brake booster.
- With ignition switch OFF, depress the brake pedal more than 40 times to decrease the accumulator pressure.

HINT:

When a pressure in power supply system is released, reaction force becomes light and stroke becomes longer.

CHECK:

Measure resistance between terminals PH and PHG of hydraulic brake booster connector.

OK:

Resistance: 0.9 – 1.1 k Ω

HINT:

After inspection, connect the connector and clear the DTC (See page DI-4).

NG

Replace hydraulic brake booster assembly.

OK

3

Check for open and short circuit in harness and connector between pressure switch and ABS & BA & TRC & VSC ECU (See page IN-35).

NG

Repair or replace harness or connector.

OK

Check and replace ABS & BA & TRC & VSC ECU.

DTC	C1256 / 56	Accumulator Low Pressure Malfunction
------------	-------------------	---

CIRCUIT DESCRIPTION

DTC No.	DTC Detecting Condition	Trouble Area
C1256 / 56	<p>Either of the following 1. through 7. is detected:</p> <ol style="list-style-type: none"> 1. With the vehicle running, when the pressure switch (PL) detects high pressure, although ABS, TRC or VSC does not control, the pressure switch (PL) detects low pressure for more than 1.4 sec. 2. With the vehicle running, when the pressure switch (PL) detects high pressure, although ABS, TRC or VSC controls, the pressure switch (PL) detects low pressure for more than 0.2 sec. 3. After the ignition switch is turned ON, the pressure switch (PL) detects low pressure for more than 64 sec. 4. With the vehicle running, after ignition switch has been ON, the pressure switch (PL) detects low pressure for more than 0.2 sec. although ABS, TRC, or VSC does not control and when the pressure switch is ON and stuck under high pressure. 5. With the vehicle running, after ignition switch is ON, the pressure switch (PL) detects low pressure for more than 0.2 sec. when ABS, TRC or VSC controls, the pressure switch is ON and stuck under high pressure. 6. With the vehicle running, after ignition switch is ON, the pressure switch (PL) is stuck to under low pressure although ABS, TRC or VSC does not control for more than 1.4 sec. 7. With the vehicle running, after ignition switch is ON, the pressure switch (PL) is stuck under low pressure when ABS, TRC or VSC controls for more than 0.2 sec. 	<ul style="list-style-type: none"> • Accumulator • Pressure switch (PH or PL) • Hydraulic brake booster pump motor

WIRING DIAGRAM

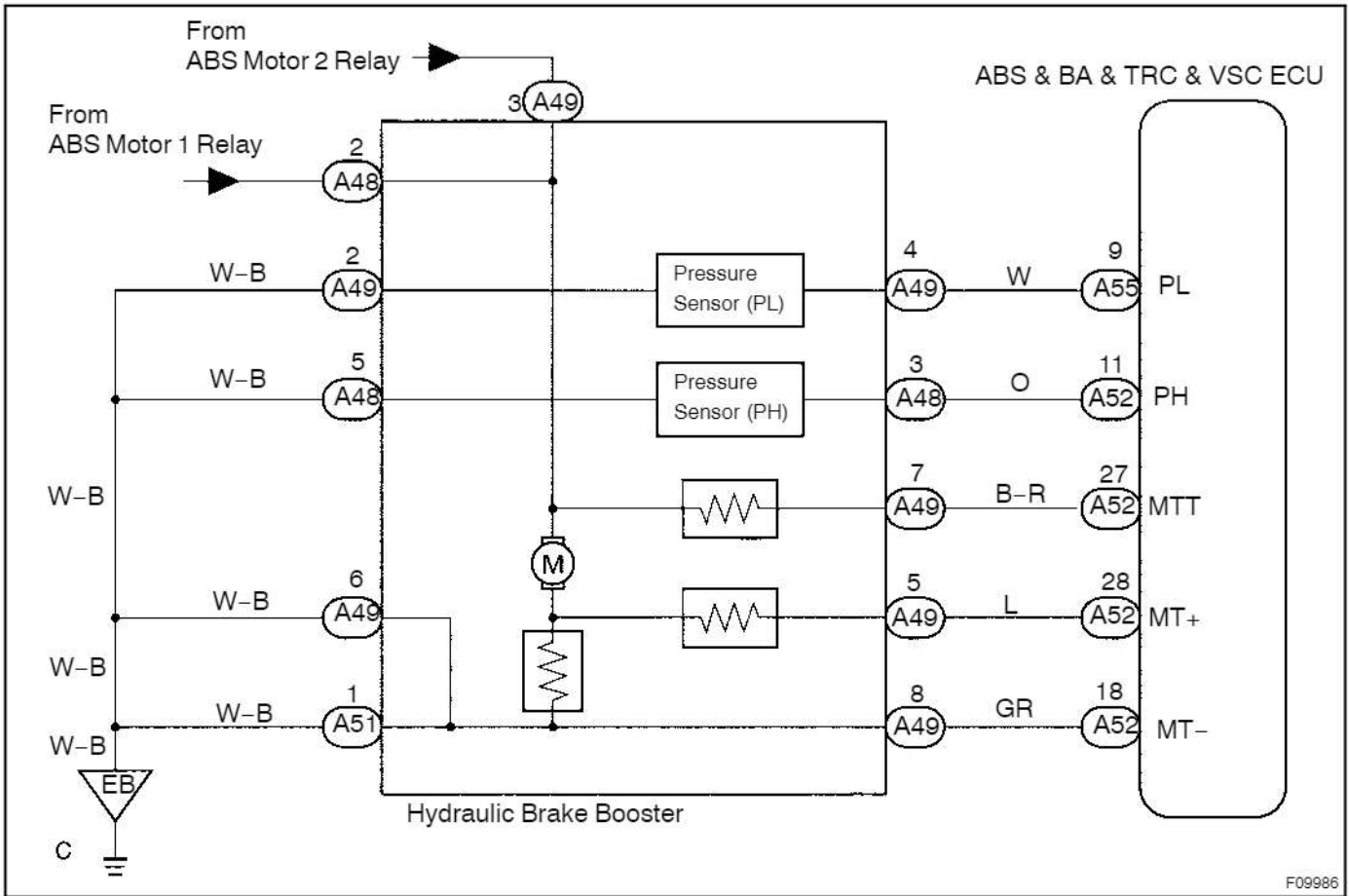

INSPECTION PROCEDURE

1	Check accumulator operation.
----------	-------------------------------------

PREPARATION:

(a) Turn the ignition switch OFF, and depress the brake pedal 40 times or more.

HINT:

When a pressure in power supply system is released, reaction force becomes light and stroke becomes longer.

(b) Install the LSPV gauge (SST) to rear brake caliper and bleed air.

SST 09709-29018

CHECK:

Depress the brake pedal with force of more than 343 N (35 kgf, 77 lbf) and turn the ignition switch ON, then check the rear brake caliper pressure when an increase of pressure changes from acutely to mildly.

OK:

5,099 – 8,924 kPa (52 – 91 kgf/cm², 740 – 1,294 psi) at 20°C (68°F)

HINT:

If the value is not within the standard, cool the engine room and check it again.

NG	Replace accumulator.
-----------	-----------------------------

OK

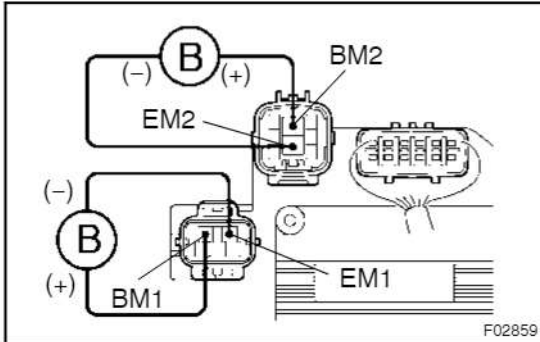
2 Check operation of hydraulic brake booster pump motor.**PREPARATION:**

Disconnect the 2 connectors from the hydraulic brake booster.

CHECK:

Connect battery positive \oplus lead to BM1 or BM2 terminal and battery negative \ominus lead to EM1 or EM2 terminal of the hydraulic brake booster (pump motor) connector.

OK:

The operation sound of the pump motor should be heard.

NG

Go to step 7.

OK

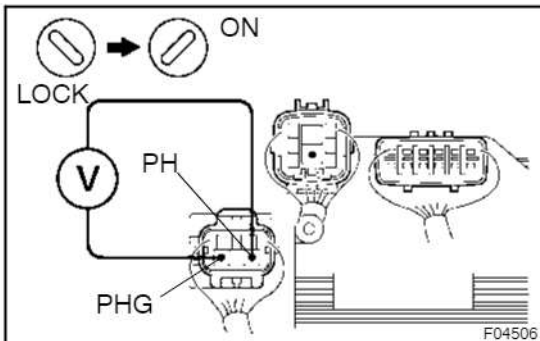
3 Check pressure switch (PH) operation.**PREPARATION:**

(a) Turn the ignition switch OFF, and depress the brake pedal 40 times or more.

HINT:

When a pressure in power supply system is released, reaction force becomes light and stroke becomes longer.

(b) Install the LSPV gauge (SST) to the rear brake caliper and bleed air.

SST 09709-29018

CHECK:

While checking the voltage between terminals PH and PHG of hydraulic brake booster, depress the brake pedal with force of more than 343 N (35 kgf, 77 lbf) and turn the ignition switch ON, then check the rear wheel cylinder pressure when voltage changes from 6 V to 0 V.

OK:

12,553 – 20,104 kpa (128 – 205 kgf·cm², 1,820 – 2,916 psi)

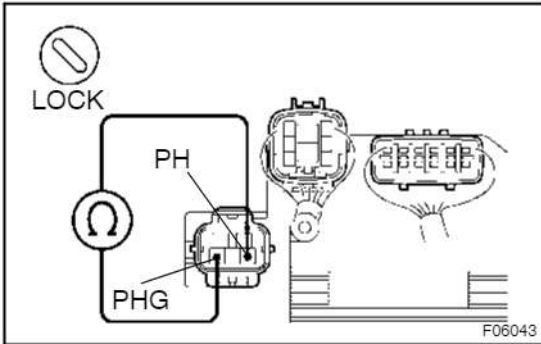

PREPARATION:

Turn the ignition switch OFF and disconnect the connector (5P) from the hydraulic brake booster.

CHECK:

While checking the resistance between terminals PH and PHG, depress the brake pedal changing the force in the range of 197 N (20 kgf, 44 lbf) to 343 N (35 kgf, 77 lbf) and check the rear wheel cylinder pressure when resistance changes from 0 kΩ to 1 kΩ between PH and PHG.

OK:

11,964 – 18,240 kpa (122 – 186 kgf·cm², 1,735 – 2,645 psi)

HINT:

After inspection, connect the connector, fill brake reservoir with brake fluid and clear the DTC (See page DI-4).

OK → Go to step 5.

NG

4 Check for open circuit in harness and connector between pressure switch (PH) and ABS & BA & TRC & VSC ECU (See page IN-35).

NG → Repair or replace harness or connector.

OK

Replace hydraulic brake booster assembly.

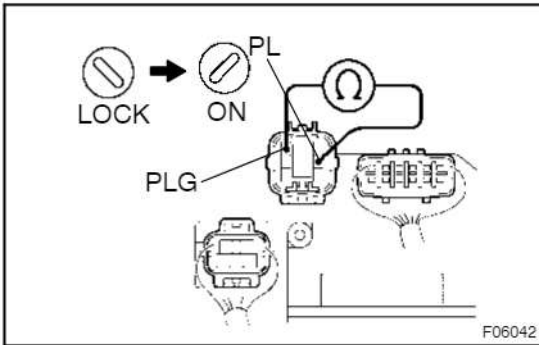
5 Check pressure switch (PL) operation.**PREPARATION:**

- (a) Turn the motor switch OFF, and depress the brake pedal 40 times or more.

HINT:

When a pressure in power supply system is released, reaction force becomes light and stroke becomes longer.

- (b) Install the LSPV gauge (SST) to the rear brake caliper and bleed air.

SST 09709 -29018

- (c) Disconnect the connector (8P) from the hydraulic brake booster.

CHECK:

While checking the resistance between terminals PL and PLG of hydraulic brake booster, depress the brake pedal with force of more than 343 N (35 kgf, 77 lbf) and turn the ignition switch ON, then check the rear wheel cylinder pressure when the resistance changes from 5.7 kΩ to 1.0 kΩ.

OK:

9,022 – 15,102 kpa (92 – 154 kgf·cm², 1,308 – 2,190 psi)

PREPARATION:

Turn the ignition switch OFF and disconnect the connector (8P) from the hydraulic brake booster.

CHECK:

While checking the resistance between terminals PL and PLG of hydraulic brake booster, depress the brake pedal changing the force in the range of 197 N (20 kgf, 44 lbf) to 343 N (35 kgf, 77 lbf) and check the rear wheel cylinder pressure when resistance changes from 1.0 kΩ to 5.7 kΩ.

OK:

8,532 – 13,337 kpa (87 – 136 kgf·cm², 1,237 – 1,934 psi)

HINT:

After inspection, connect the connector, fill brake reservoir with brake fluid and clear the DTC (See page DI-4).

NG**Replace hydraulic brake booster assembly.****OK**

6 Check pressure switch (PH) and pressure switch (PL)**CHECK:**

Compare the pressure value of the rear wheel cylinder measured in check pressure switch (PL) operation with the one measured in check pressure switch (PH) operation.

OK:

- Pressure when the voltage between PH and PHG becomes 6 to 0 V > pressure when the resistance between PL and PLG becomes 5.7 k Ω to 1.0 k Ω .
- Pressure when the resistance between PH and PHG becomes 0 k Ω to 1 k Ω > pressure when the resistance between PL and PLG becomes 1.0 k Ω to 5.7 k Ω .

NG

Replace hydraulic brake booster assembly.

OK

Check and replace ABS & BA & TRC & VSC ECU.

7 Check for open or short circuit in harness and connector between hydraulic brake booster pump motor and hydraulic brake booster (See page IN-35).**NG**

Replace wire harness.

OK**8 Check hydraulic brake booster pump motor (See page BR-32).****NG**

Replace hydraulic brake booster pump motor.

OK

Replace hydraulic brake booster.

DTC	C1257 / 57	Power Supply Drive Circuit
------------	-------------------	-----------------------------------

CIRCUIT DESCRIPTION

DTC No.	DTC Detecting Condition	Trouble Area
C1257 / 57	When malfunction inside ECU is detected.	<ul style="list-style-type: none"> • Battery • Power source circuit • ABS & BA & TRC & VSC ECU

WIRING DIAGRAM

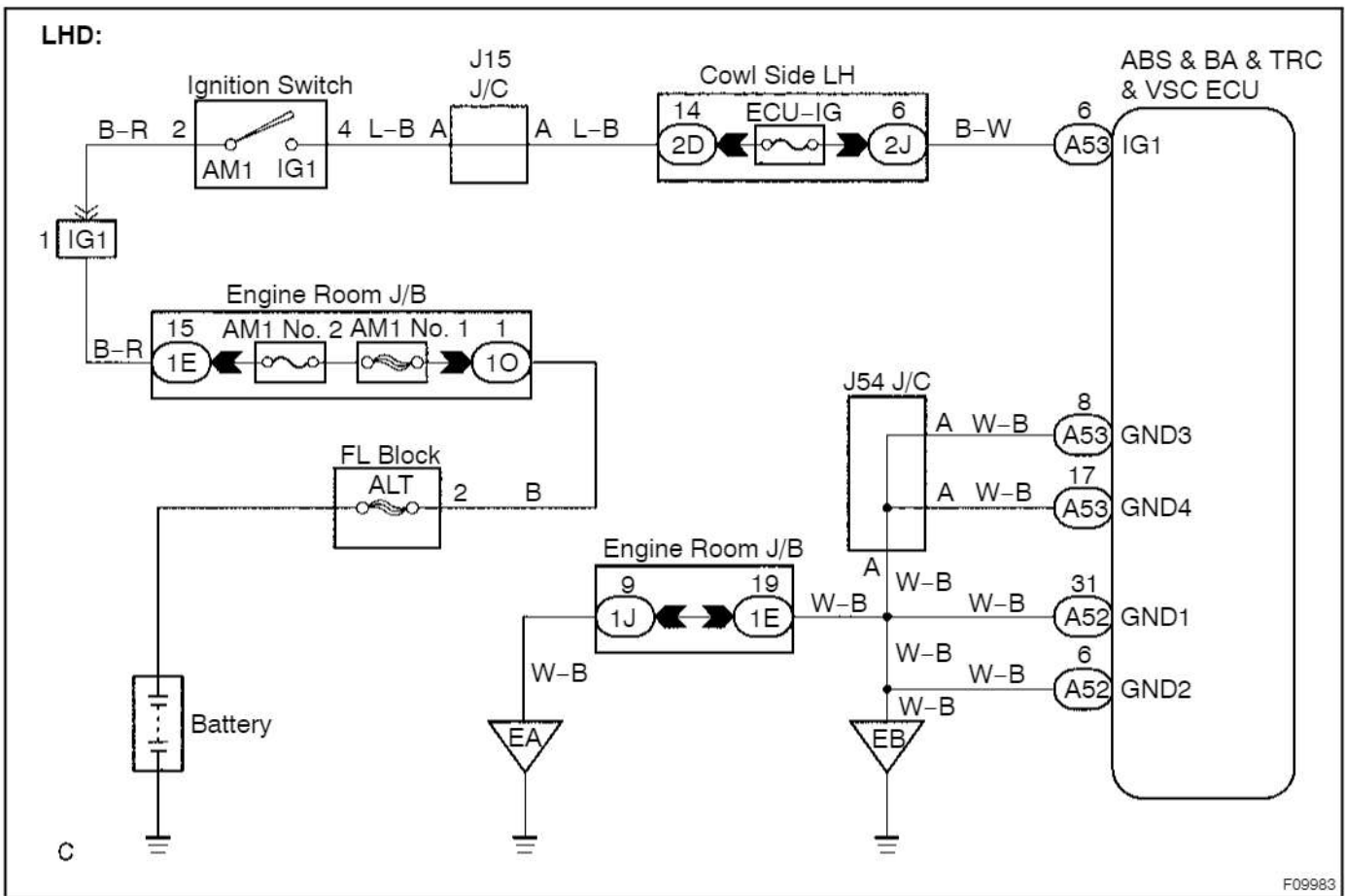

cardiagn.com

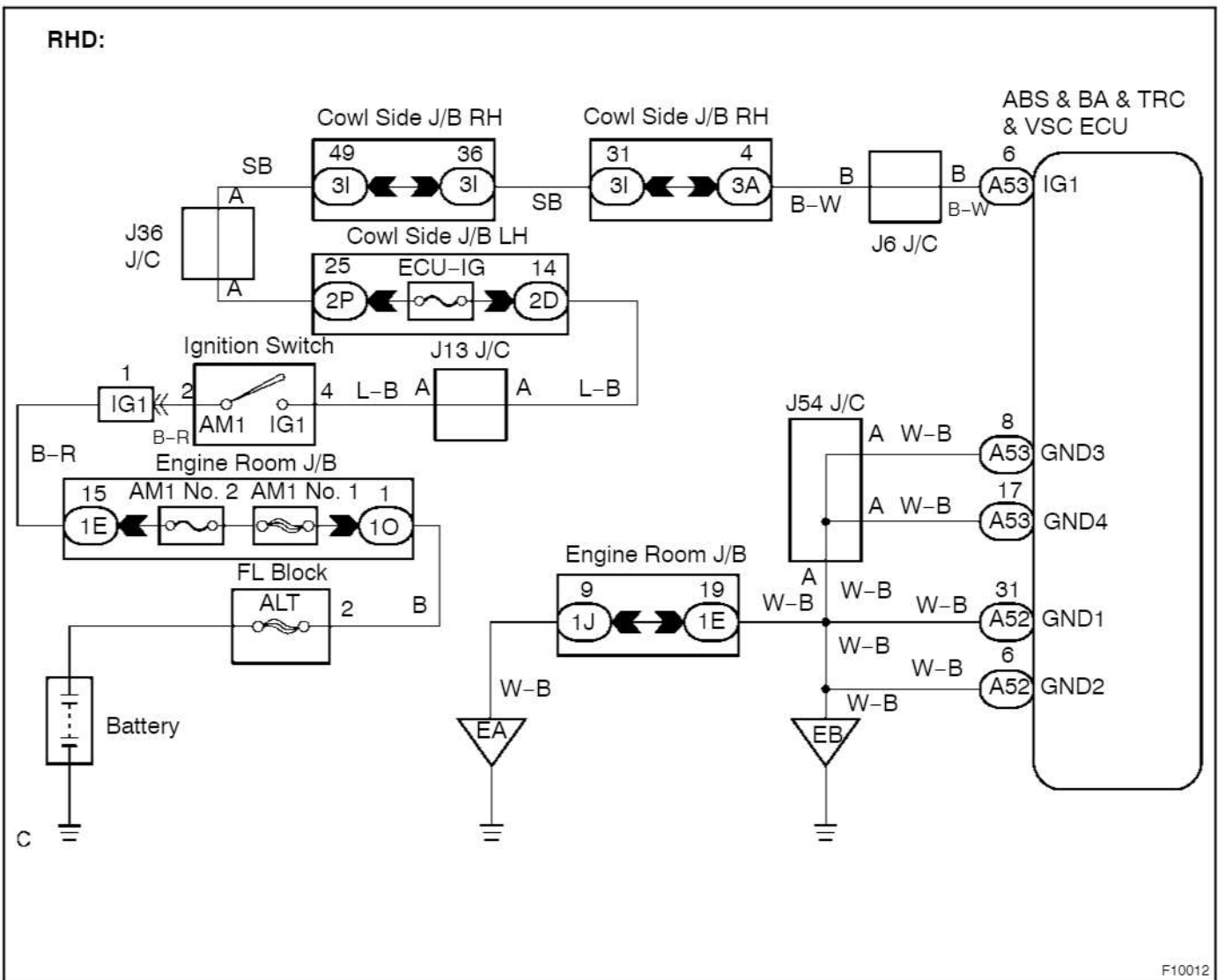

INSPECTION PROCEDURE

1	Check battery voltage.
---	-------------------------------

OK:

Voltage: 10 - 14 V

NG	Check and repair the charging system.
-----------	--

OK

2	Check voltage of the ECU IG power source.
----------	--

In case of using the hand-held tester.

PREPARATION:

- (a) Connect the hand-held tester to the DLC3.
- (b) Turn the ignition switch ON and push the hand-held tester main switch ON.
- (c) Select the DATALIST mode on the hand-held tester.

CHECK:

Check the voltage condition output from the ECU displayed on the hand-held tester.

OK:

"Normal" is displayed.

In case of not using the hand-held tester:

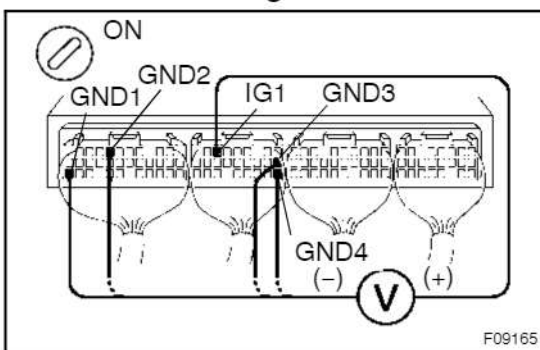

PREPARATION:

Remove ABS & BA & TRC & VSC ECU with connectors still connected.

CHECK:

- (a) Turn the ignition switch ON.
- (b) Measure voltage between terminals IG1 and GND of ABS & BA & TRC & VSC ECU connector.

OK:

Voltage: 10 - 14 V

OK

Turn ignition switch OFF, check and replace ABS & BA & TRC & VSC ECU.

NG

3	Check continuity between terminal GND of ABS & BA & TRC & VSC ECU connector and body ground.
----------	---

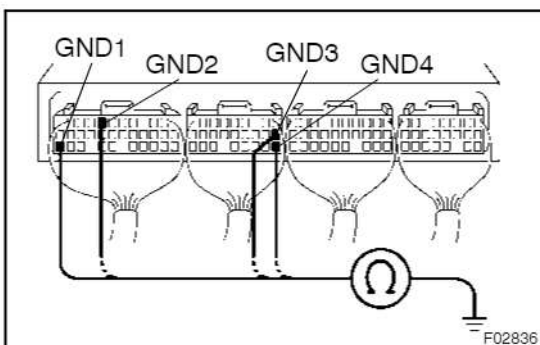

CHECK:

Measure resistance between terminal GND of ABS & BA & TRC & VSC ECU connector and body ground.

OK:

Resistance: 1 Ω or less

NG

Repair or replace harness or connector.

OK

4 Check ECU-IG fuse.

Cowl Side J/B LH:

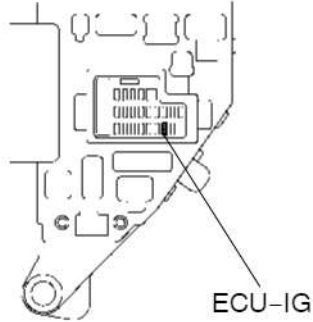

F04448

PREPARATION:

Remove ECU-IG fuse from the cowl side J/B LH.

CHECK:

Check continuity of ECU-IG fuse.

OK:

Continuity

NG

Check for short circuit in all the harness and components connected to ECU-IG fuse (See attached wiring diagram).

OK

Check for open circuit in harness and connector between ABS & BA & TRC & VSC ECU and battery (See page IN-35).

DTC	C1268 / 68	Transfer L4 Position Switch Circuit
------------	-------------------	--

CIRCUIT DESCRIPTION

DTC No.	DTC Detecting Condition	Trouble Area
C1268 / 68	Open or short circuit in transfer L4 position switch.	<ul style="list-style-type: none"> • Transfer L4 position switch • Transfer L4 position switch circuit

WIRING DIAGRAM

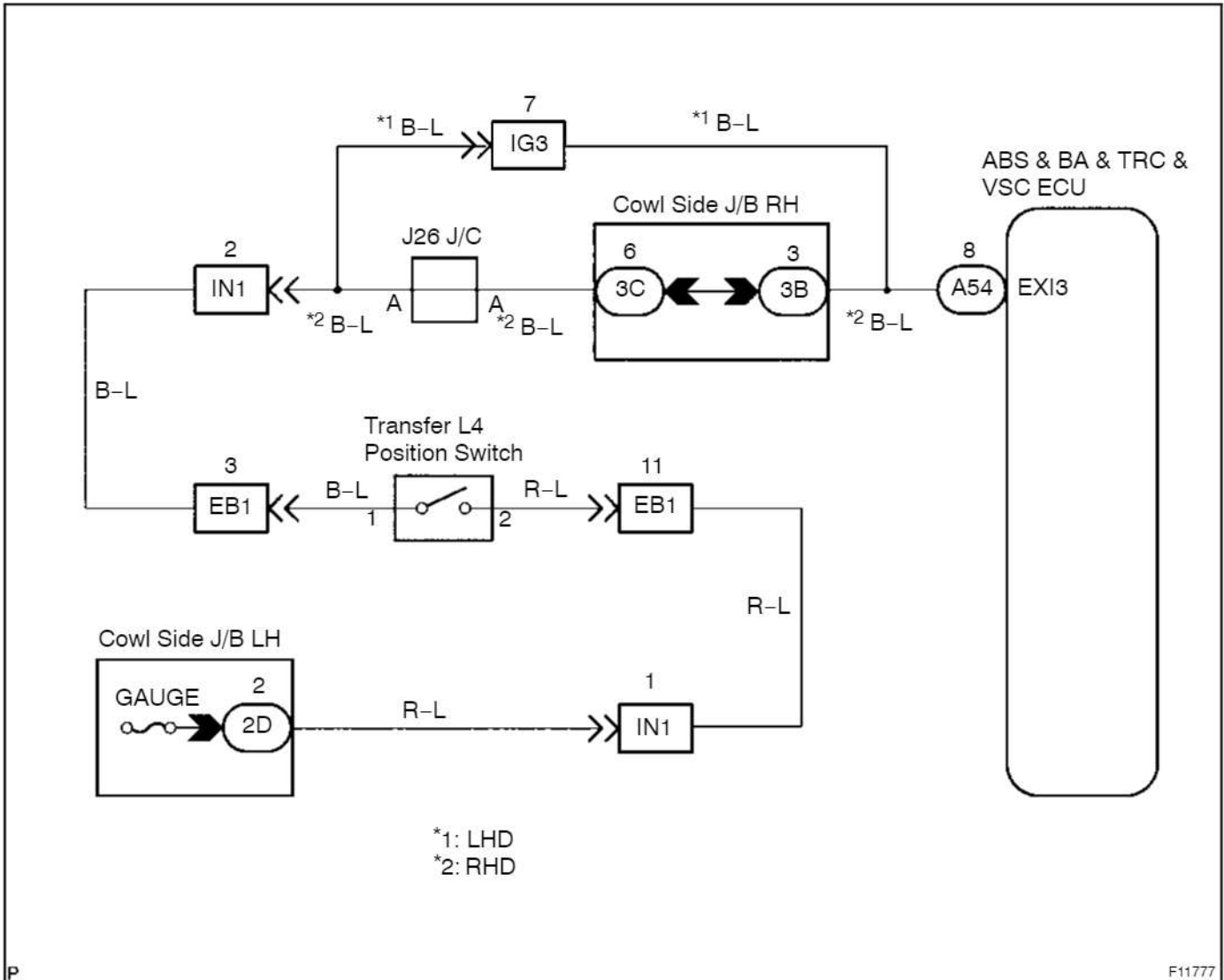

cardiagn.com

INSPECTION PROCEDURE

- 1 Check voltage between terminal EX13 of ABS & BA & TRC & VSC ECU and body ground.**

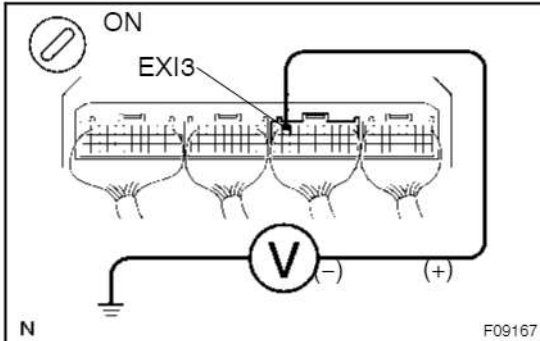

PREPARATION:

Remove ABS & BA & TRC & VSC ECU with connectors still connected.

CHECK:

- (a) Turn the ignition switch ON.
- (b) Measure voltage between terminal EX13 of ABS & BA & TRC & VSC ECU and body ground when transfer in L4 position.

OK:

Voltage: 10 - 14 V

OK

Proceed to next circuit inspection shown in problem symptoms chart (See page DI-23).

NG

- 2 Check transfer L4 position switch (Full-time 4WD type: See Pub. No. RM616E on page TR-53).**

NG

Replace transfer L4 position switch.

OK

- 3 Check for open or short circuit in harness and connector between transfer L4 position switch and ABS & BA & TRC & VSC ECU (See page IN-35).**

NG

Repair or replace harness or connector.

- | | |
|----------|---|
| 4 | Check for open or short circuit in harness and connector between ABS & BA & TRC & VSC ECU and engine and ECT ECU (See page IN-35). |
|----------|---|

NG

Repair or replace harness or connector.

OK

Check and replace ABS & BA & TRC & VSC ECU.

DTC	C1269 / 69	Neutral Start Switch Circuit (R Range)
------------	-------------------	---

CIRCUIT DESCRIPTION

DTC No.	DTC Detecting Condition	Trouble Area
C1269 / 69	With the vehicle speed less than 15 km/h (9 mph) when an open circuit signal of R signal is detected for more than 2 sec.	<ul style="list-style-type: none"> • Neurral start switch • Neutral start switch circuit (R range)

WIRING DIAGRAM

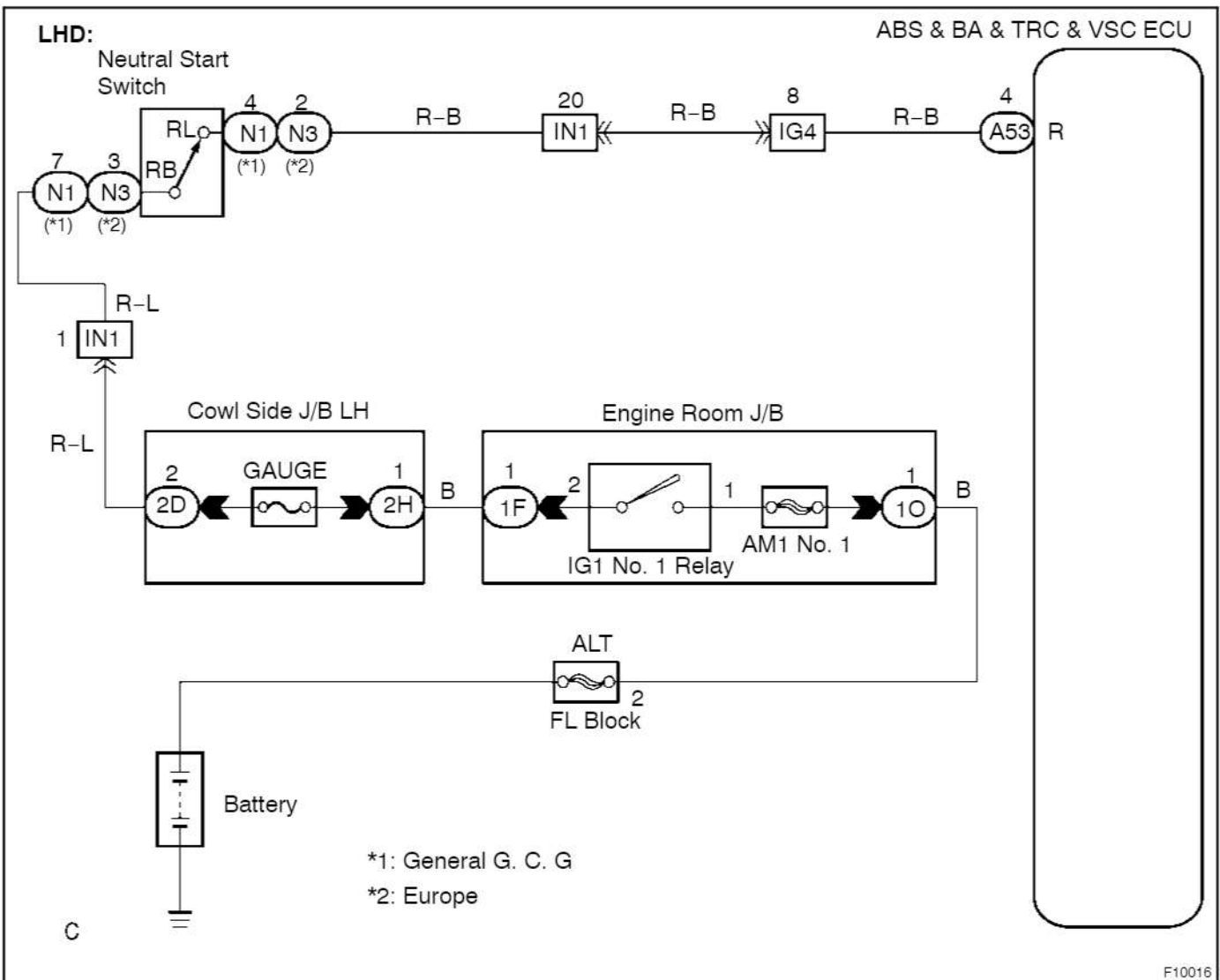

cardiagn.com

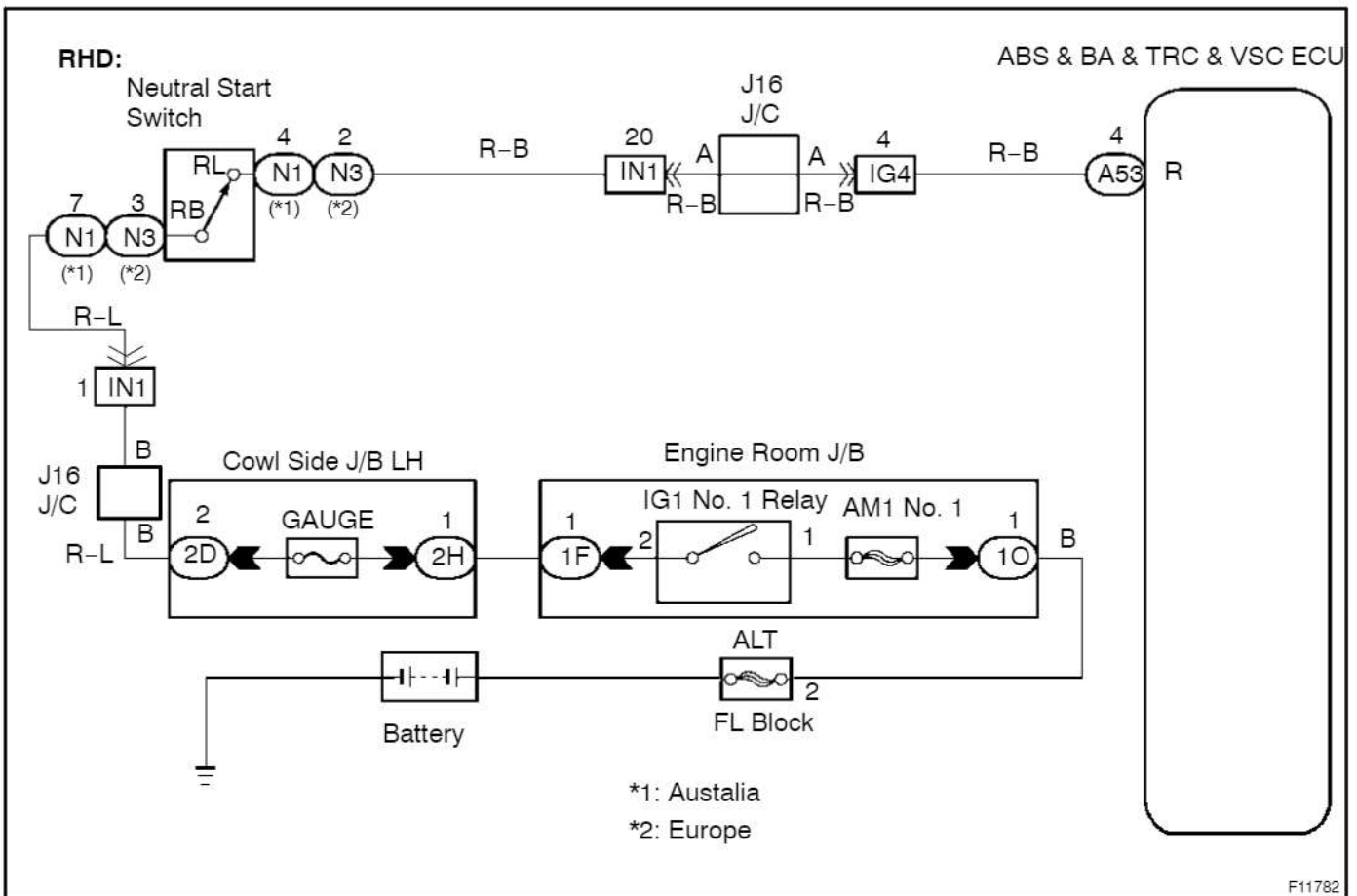

INSPECTION PROCEDURE

HINT:

Start the inspection from step 1 in case of using the hand-held tester and start from step 2 in case of not using the hand-held tester.

1	Check operation of the neutral start switch (R range) circuit.
---	---

PREPARATION:

- Connect the hand-held tester to the DLC3.
- Turn the ignition switch ON and push the hand-held tester main switch ON.
- Select the ACTIVE TEST mode on the hand-held tester.

CHECK:

Shift lever into the R range, and read the R signal on the hand-held tester.

OK:

"ON" is displayed.

OK

Check and replace ABS & BA & TRC & VSC ECU.

NG

2 Check neutral start switch (R range) (See page DI-44).

NG Repair or replace neutral start switch.

OK

3 Check voltage between terminal R of ABS & BA & TRC & VSC ECU and body ground.

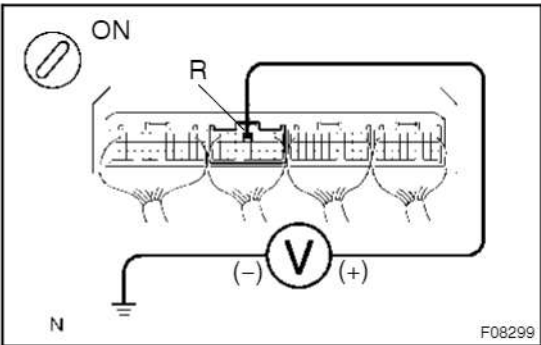

PREPARATION:

Remove ABS & BA & TRC & VSC ECU with connectors still connected.

CHECK:

- (a) Turn the ignition switch ON.
- (b) Measure voltage between terminal R of ABS & BA & TRC & VSC ECU and body ground when shift lever is in R range.

OK:

Voltage: 10 - 14 V

NG Go to step 4.

OK

If the same code is still output after the DTC is deleted, check the contact condition of each connection. If the connections are normal, the ECU may be defective.

4 Check for open circuit in harness and connector between neutral start switch (R range) and ABS & BA & TRC & VSC ECU (See page IN-35).

NG Repair or replace harness or connector.

OK

Check and replace ABS & BA & TRC & VSC ECU.

DTC	C1336 / 39	Zero Point Calibration of Deceleration Sensor Undone
------------	-------------------	---

CIRCUIT DESCRIPTION

DTC No.	DTC Detecting Condition	Trouble Area
C1236 / 39	When any of following 1. through 2. is detected: 1. In TEST mode, the shift lever is shifted to other than P range with 2 sec. after ECU terminal IG1 is turned ON for the first time. 2. When the deceleration sensor zero point recorded in ECU is deleted.	<ul style="list-style-type: none"> • Deceleration sensor • Deceleration sensor circuit • Neutral start switch circuit (R range)

WIRING DIAGRAM

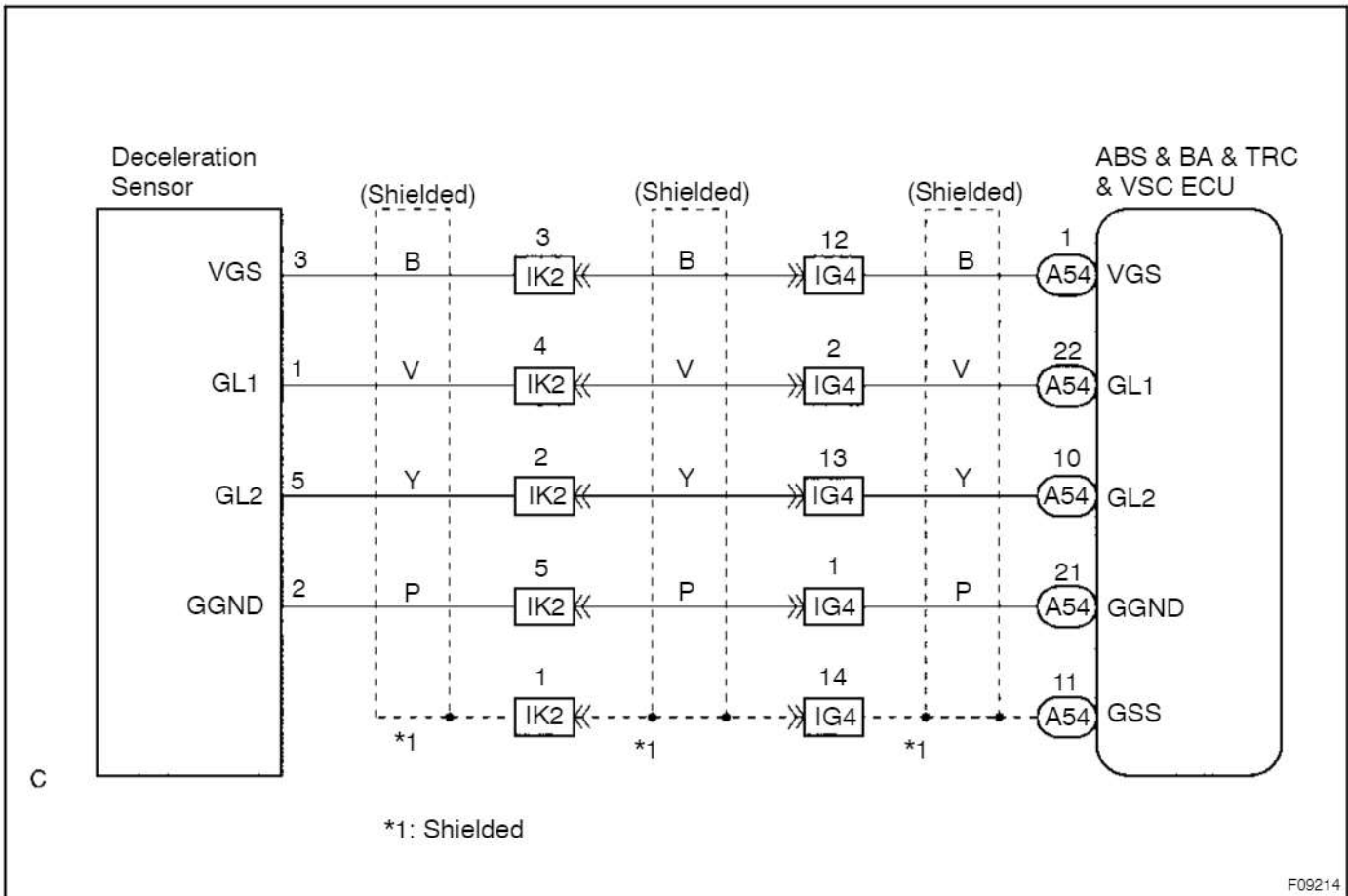

cardiagn.com

INSPECTION PROCEDURE

1	Check whether zero point calibration of deceleration sensor has been done or not.
----------	--

PREPARATION:

Shift the shift lever in P range and turn the ignition switch ON, repeat connecting and releasing Ts and E₁ terminals of check connector 4 times or more for 8 sec. After that do not move the vehicle for 15 sec. or more.

CHECK:

VSC TRC warning light remains on.

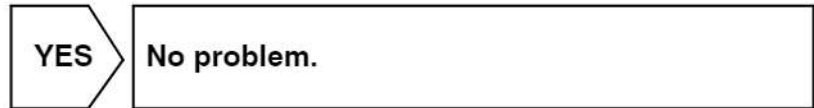

2	Carry out deceleration sensor zero point calibration and confirm it by VSC TRC warning light.
----------	--

OK:

VSC TRC warning light blinks



3	Check DTC for the VSC (See page DI-4).
----------	---

*1: Other than DTC C1336 / 39 is output.

*2: DTC C1336 / 39 only is output.

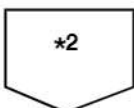

4	Check for open and short circuit in harness and connector between neutral start switch (P range) and ABS & BA & TRC & VSC ECU and engine and ECT ECU (See page IN-35).
----------	---

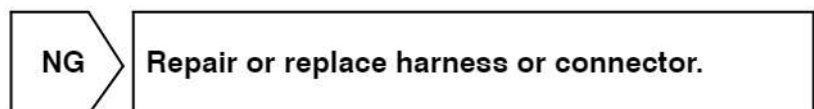

5 Check for open and short circuit in harness and connector between deceleration sensor and ABS & BA & TRC & VSC ECU (See page IN-35).

NG

Repair or replace harness or connector.

OK

6 Check deceleration sensor (See page DI-4).

NG

Replace deceleration sensor.

OK

Check and replace ABS & BA & TRC & VSC ECU.

DTC	C1340 / 47	Center Differential Lock Circuit
------------	-------------------	---

CIRCUIT DESCRIPTION

DTC No.	DTC Detecting Condition	Trouble Area
C1240 / 47	Open or short circuit in center differential lock circuit.	<ul style="list-style-type: none"> Center differential lock system Center differential lock circuit

WIRING DIAGRAM

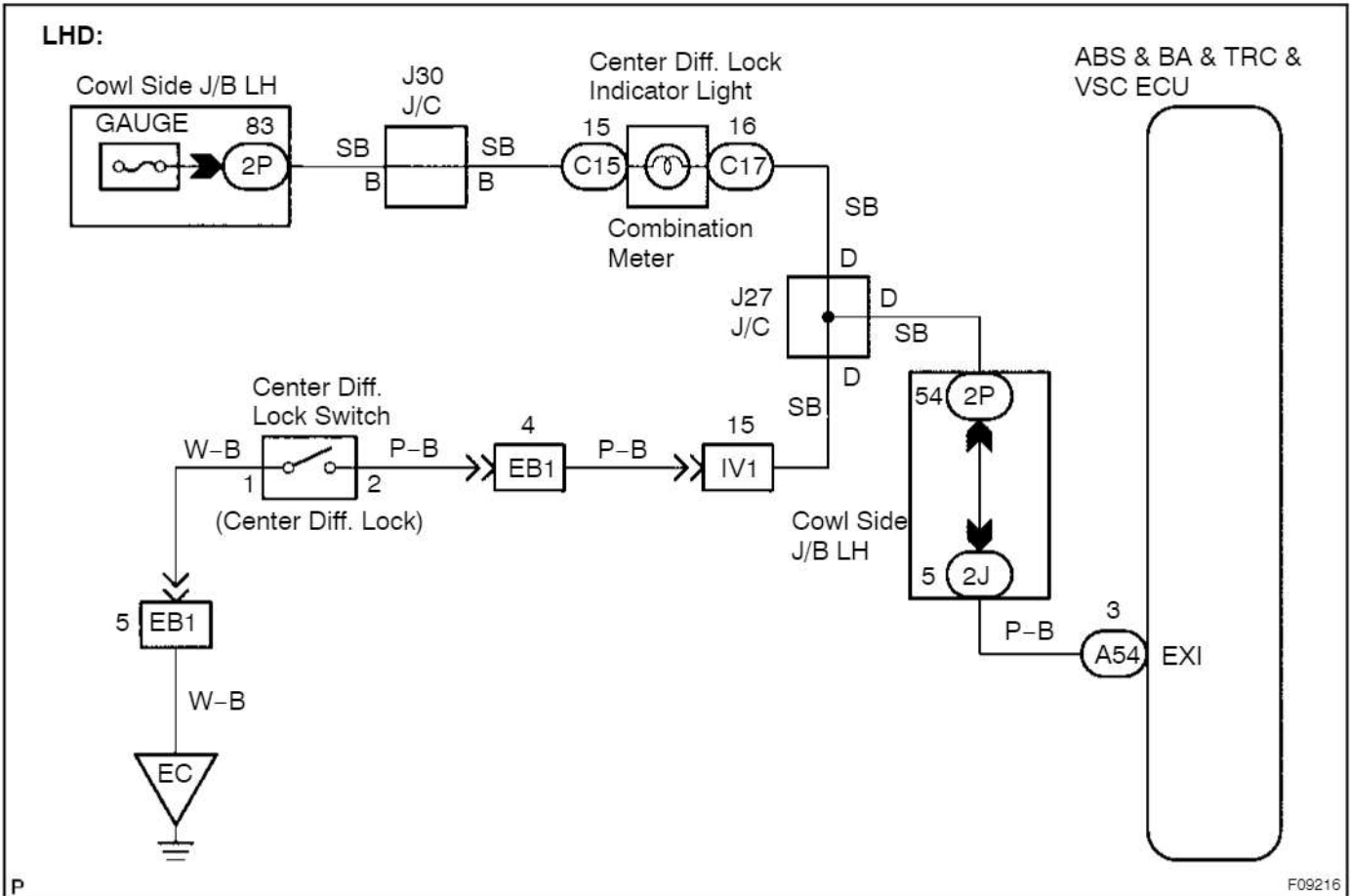

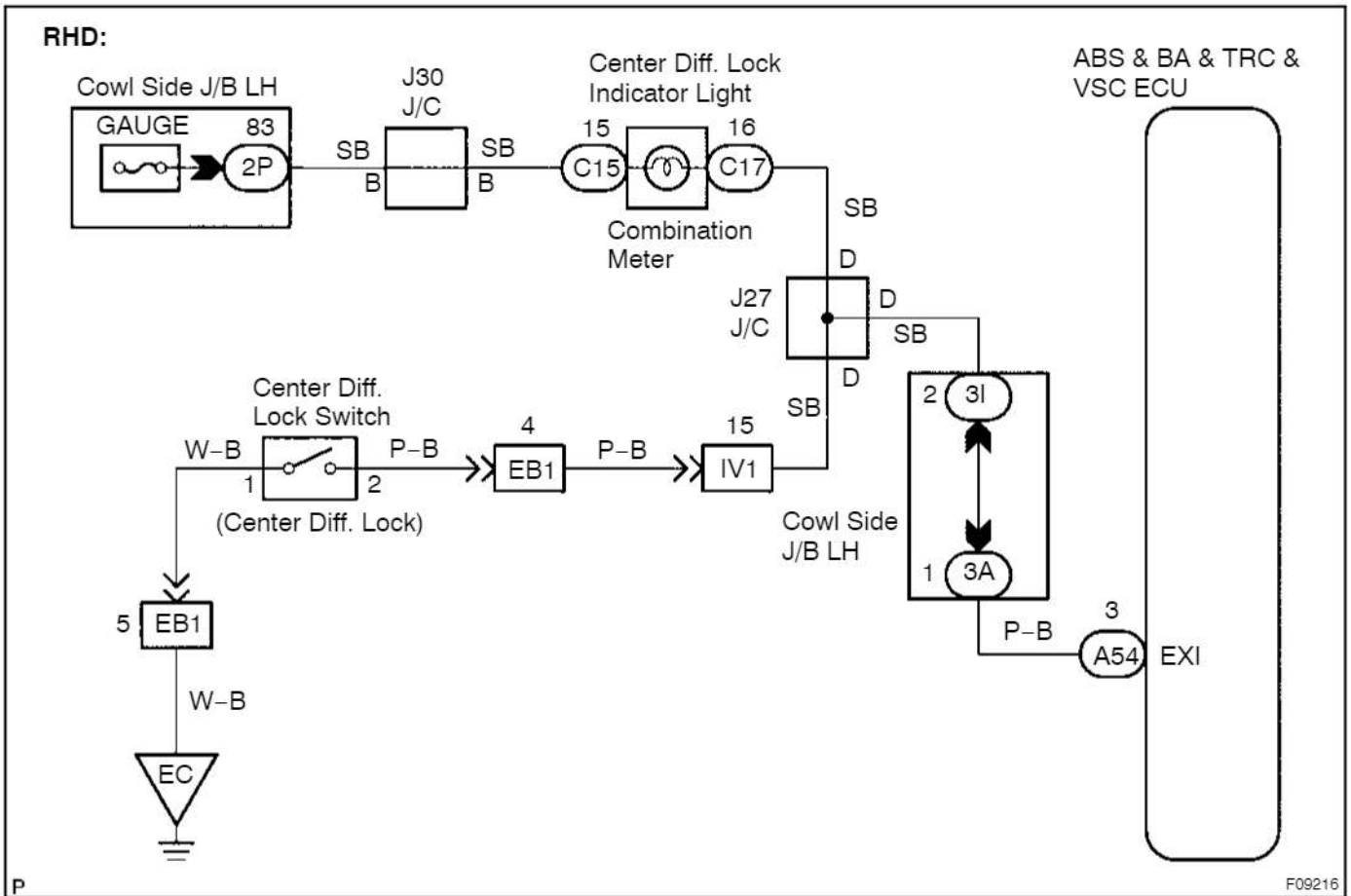

INSPECTION PROCEDURE

1 Check the center differential is free and center diff. lock switch is OFF.

NG Repair the center differential lock system.

OK

2 Is DTC output?

Check DTC on [page DI-4](#).

NO Normal.

YES

3	Check that bulb for center diff. lock indicator light is not burnt out.
----------	--

YES

Replace indicator light.

NO

4	Check for open circuit in harness and connector between battery and center diff. lock indicator light, center diff. lock indicator light and ABS & BA & TRC & VSC ECU (See page IN-35).
----------	--

NG

Repair or replace harness or connector.

OK

Check and replace ABS & BA & TRC & VSC ECU.

cardiagn.com

DTC	Always ON	Malfunction in ECU
------------	------------------	---------------------------

CIRCUIT DESCRIPTION

DTC No.	DTC Detecting Condition	Trouble Area
Always ON	Either of the following 1. or 2. is detected: 1. The ECU connectors are OFF from the ECU. 2. There is a malfunction in the ECU internal circuit.	<ul style="list-style-type: none"> • Battery • IC regulator • Power source circuit • ABS & BA & TRC & VSC ECU

HINT:

There is a case that hand-held tester cannot be used when ECU is abnormal.

Fail safe function:

If trouble occurs in the ECU, the ECU cuts off current to the ABS solenoid relay and prohibits ABS & BA & TRC & VSC controls. When fail safe function in ABS system is activated, "VSC TRC" warning light and "VSC OFF" indicator light tight up.

WIRING DIAGRAM

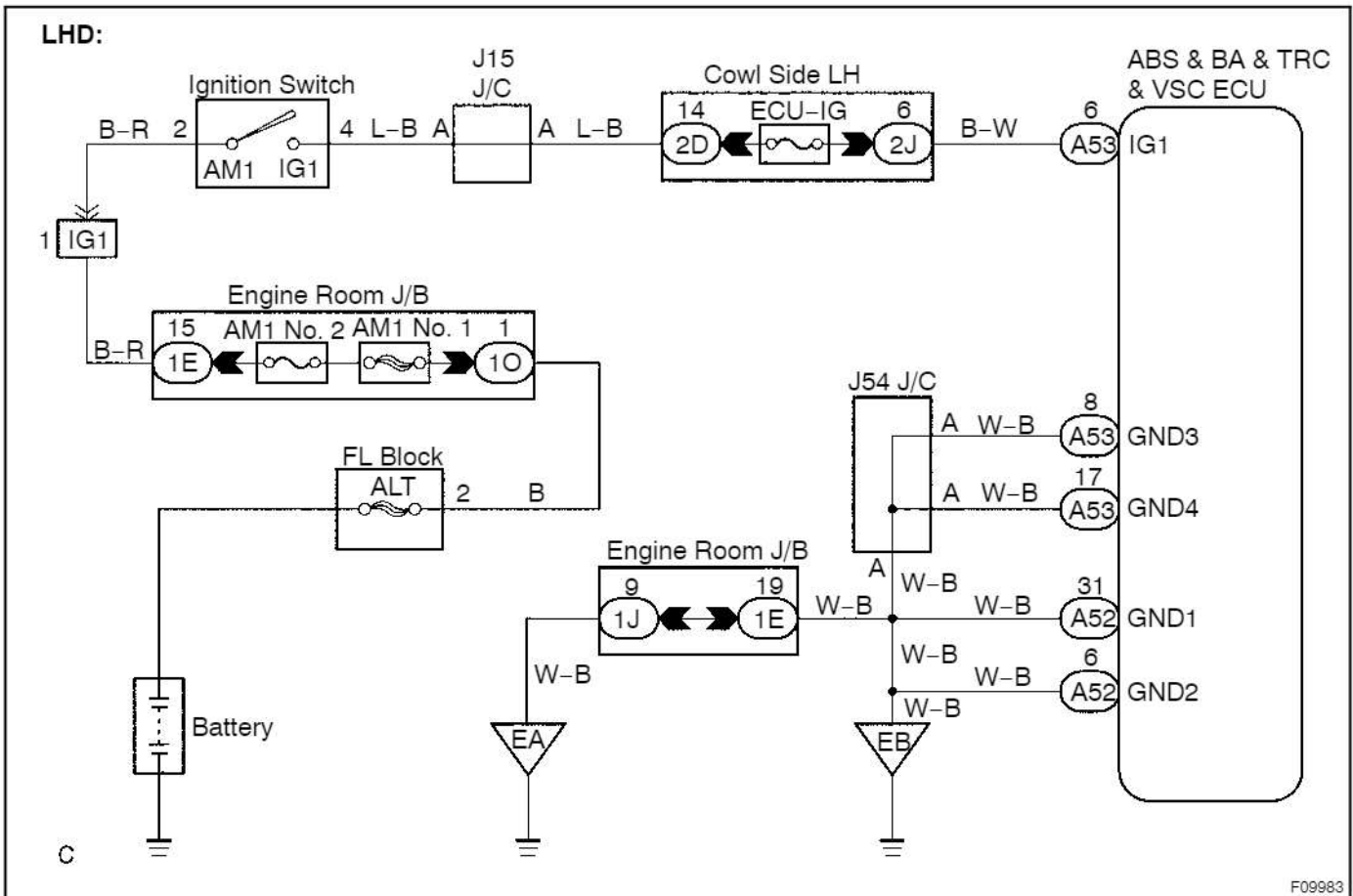

F09983

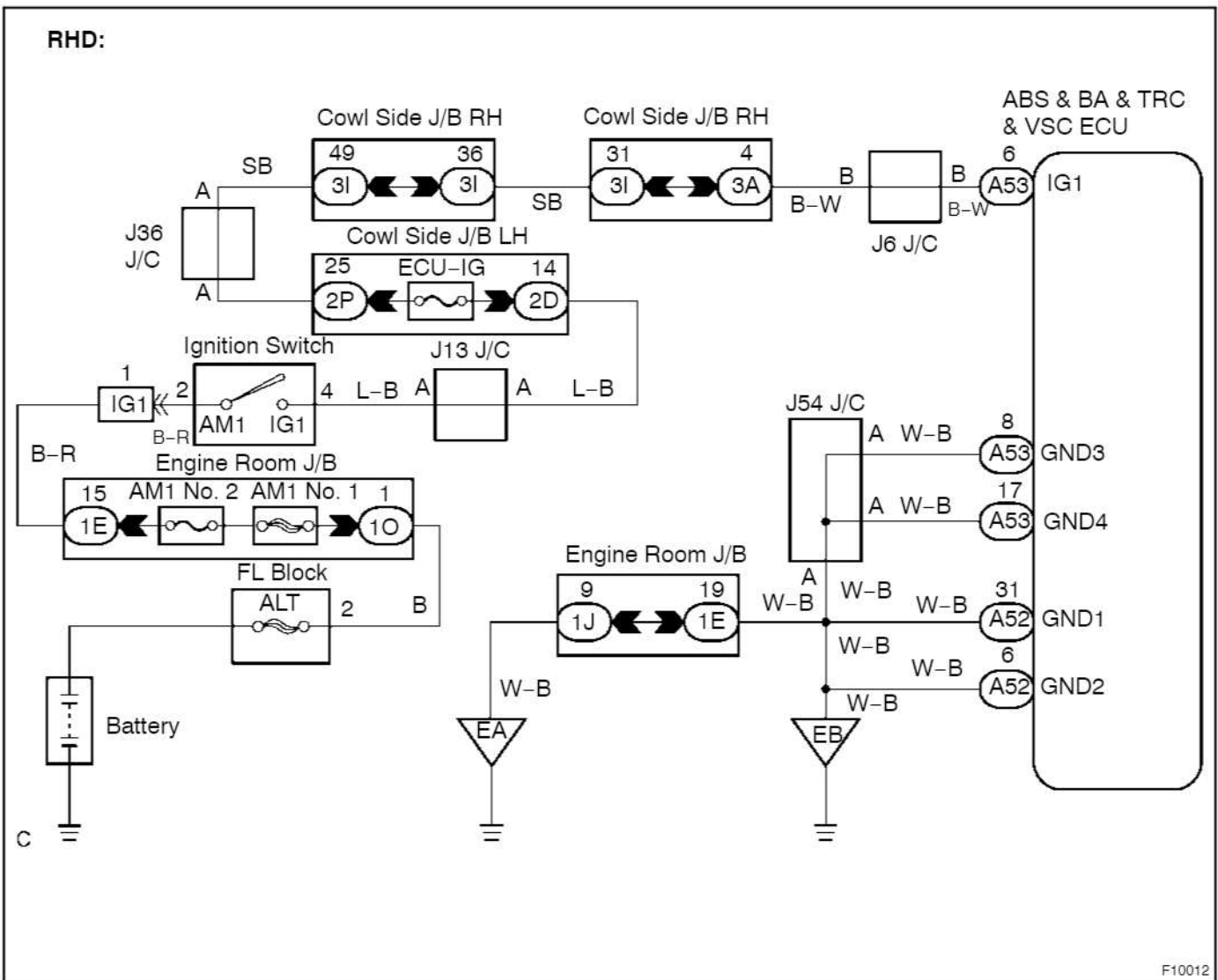

INSPECTION PROCEDURE

1	Check that the ECU connectors are securely connected to the ECU.
---	--

NO
Connect the connector to the ECU.

YES

2 Is DTC output?

Check DTC on [page DI-4](#).

YES

Repair circuit indicated by the output code.

NO

3 Does ABS warning light go off?

YES

Check for open or short circuit in harness and connector between ECU-IG fuse and ECU ([See page IN-35](#)).

NO

4 Check battery voltage.

PREPARATION:

Start the engine.

CHECK:

Check the battery voltage.

OK:

Voltage: 10 - 14 V

NG

Check and repair the charging system.

OK

5	Check operation of the ABS warning light.
----------	--

In case of using the hand-held tester:

PREPARATION:

- (a) Connect the hand-held tester to the DLC3.
- (b) Turn the ignition switch ON and push the hand-held tester main switch ON.
- (c) Select the ACTIVE TEST mode on the hand-held tester.

CHECK:

Check that "ON" and "OFF" of the ABS warning light can be shown on the combination meter by the hand-held tester.

In case of not using the hand-held tester:

PREPARATION:

- (a) Turn the ignition switch OFF.
- (b) Disconnect the connector from the ABS & BA & TRC & VSC ECU.
- (c) Turn the ignition switch ON.

CHECK:

Check the ABS warning goes off.

OK	Check and replace combination meter (See page BE-1).
-----------	---

NG

6	Check for short circuit in harness and connector between combination meter and ABS & BA & TRC & VSC ECU, combination meter and check connector (See page IN-35).
----------	---

NG	Repair or replace harness or connector.
-----------	--

OK

Check and replace ABS & BA & TRC & VSC ECU.
--

DTC	Always ON	Malfunction in ECU VSC TRC Warning Light Circuit
------------	------------------	---

CIRCUIT DESCRIPTION

DTC No.	DTC Detecting Condition	Trouble Area
Always ON	There is a malfunction in the ECU internal circuit.	<ul style="list-style-type: none"> • Power source circuit • ABS & BA & TRC & VSC ECU • VSC TRC warning light circuit

Fail safe function:

If trouble occurs in the ECU, the ECU prohibits ABS & BA & TRC & VSC controls and the brake system becomes normal.

HINT:

If fail safe function is activated in VSC system, "VSC OFF" indicator light lights up.

WIRING DIAGRAM

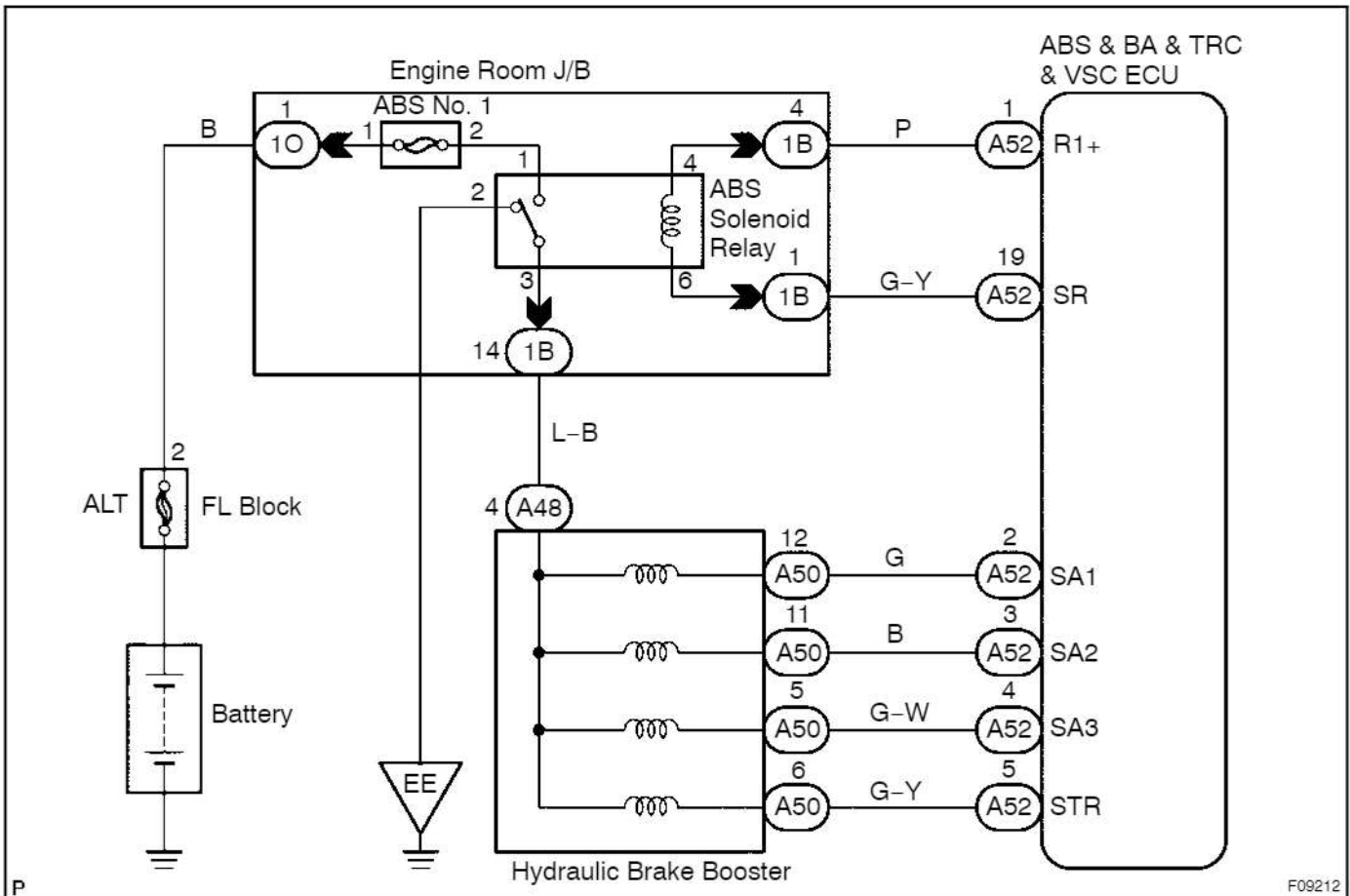

cardiagn.com

INSPECTION PROCEDURE

1	Check that the ECU connectors are securely connected to the ECU.
---	--

NO	Connect the connector to the ECU.
----	-----------------------------------

YES

2	Is DTC output for VSC?
---	------------------------

Check DTC on [page DI-4](#).

YES	Repair circuit indicated by the output code.
-----	--

NO

3	Does VSC TRC warning light go off?
---	------------------------------------

YES	Check for open or short circuit in harness and connector between ECU-IG fuse and ECU (See page IN-35).
-----	--

NO

4	Check battery voltage.
---	------------------------

PREPARATION:

Start the engine.

CHECK:

Check the battery voltage.

OK:

Voltage: 10 - 16 V

NG	Check and repair the charging system.
----	---------------------------------------

OK

5	Check operation of the VSC TRC warning light.
----------	--

In case of using the hand-held tester:

PREPARATION:

- (a) Connect the hand-held tester to the DLC3.
- (b) Turn the ignition switch ON and push the hand-held tester main switch ON.
- (c) Select the ACTIVE TEST mode on the hand-held tester.

CHECK:

Check that "ON" and "OFF" of the VSC TRC warning light can be shown on the combination meter on the hand-held tester.

In case of not using the hand-held tester:

PREPARATION:

- (a) Turn the ignition switch OFF.
- (b) Disconnect the connector from the ABS & BA & TRC & VSC ECU.
- (c) Turn the ignition switch ON.

CHECK:

Check the VSC TRC warning light goes off.

NG

Check and replace combination meter (See page BE-1).

OK

Check and replace ABS & BA & TRC & VSC ECU.

ABS Warning Light Circuit

CIRCUIT DESCRIPTION

If the ECU detects trouble, it lights the ABS warning light while at the same time prohibiting ABS control. At this time, the ECU records a DTC in memory.

Connect terminals Tc and E₁ of the check connector to make the ABS warning light blink and output the DTC.

WIRING DIAGRAM

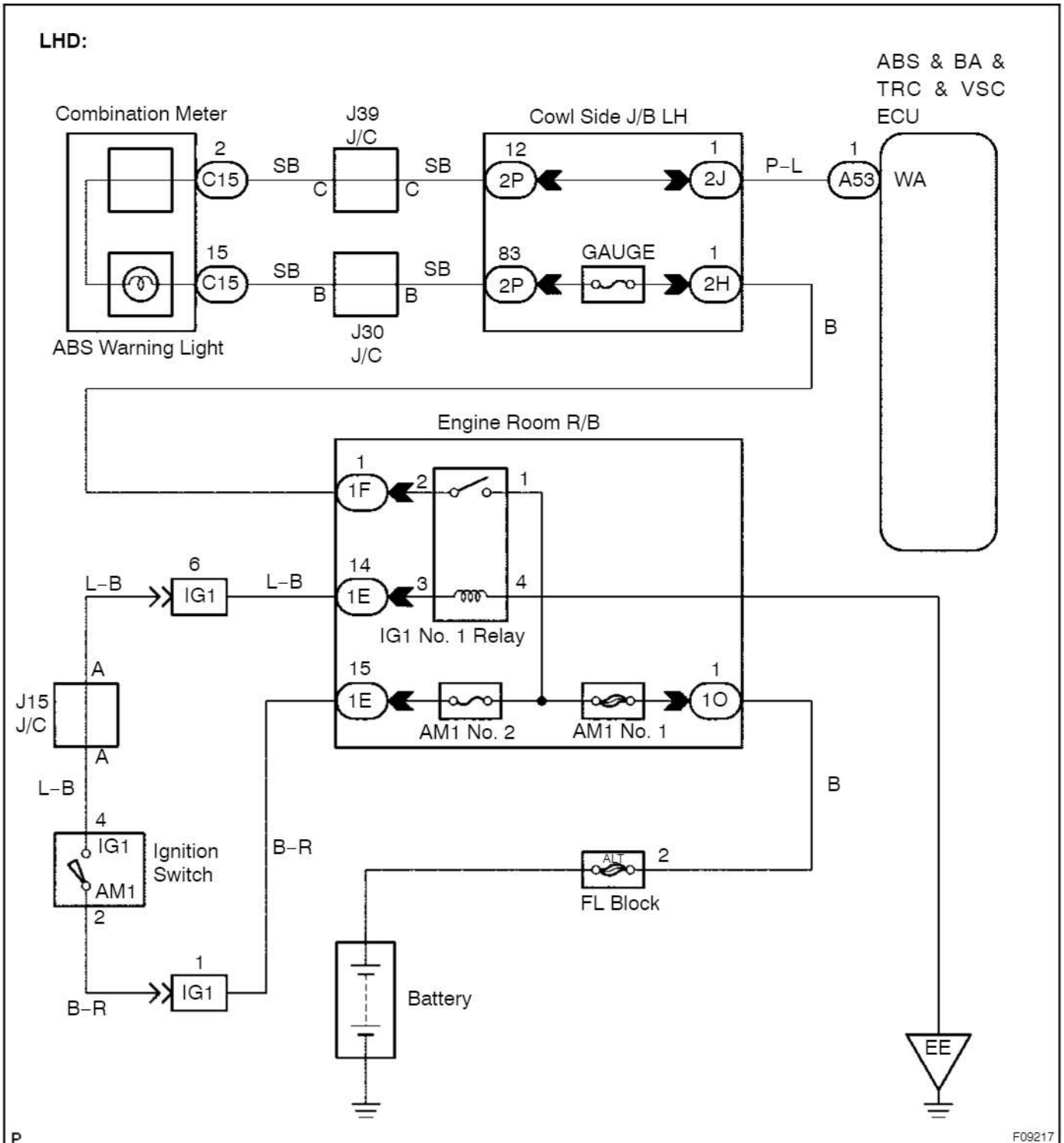

RHD:

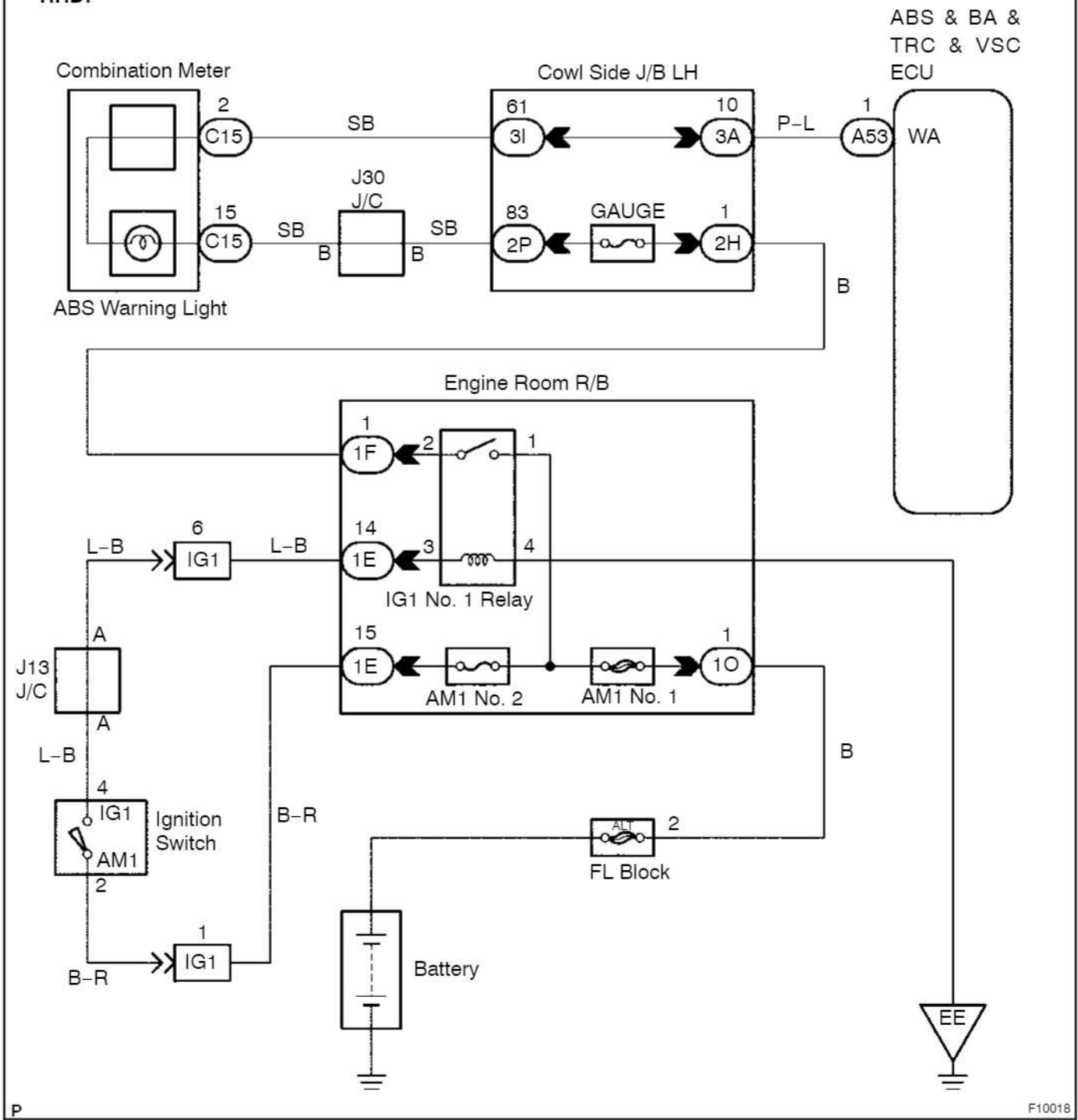

cardiagn.com

P

F10018

INSPECTION PROCEDURE

HINT:

Troubleshoot in accordance with the chart below for each trouble symptom.

ABS warning light does not light up	*1
ABS warning light remains on	*2

*1: Start the inspection from step 1 in case of using the hand-held tester and start from step 2 in case of not using hand-held tester.

*2: After inspection with step 4, start the inspection from step 5 in case of using the hand-held tester and start from step 6 in case of not using hand-held tester.

1	Check operation of the ABS warning light.
----------	--

PREPARATION:

- (a) Connect the hand-held tester to the DLC3.
- (b) Turn the ignition switch ON and push the hand-held tester main switch ON.
- (c) Select the ACTIVE TEST mode on the hand-held tester.

CHECK:

Check that "ON" and "OFF" of the ABS warning light can be shown on the combination meter on the hand-held tester.



2	Does the warning lights other than ABS warning lights up?
----------	--

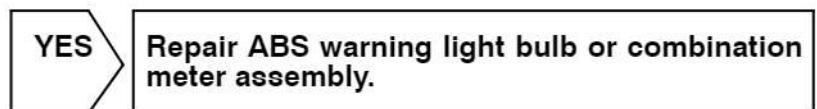

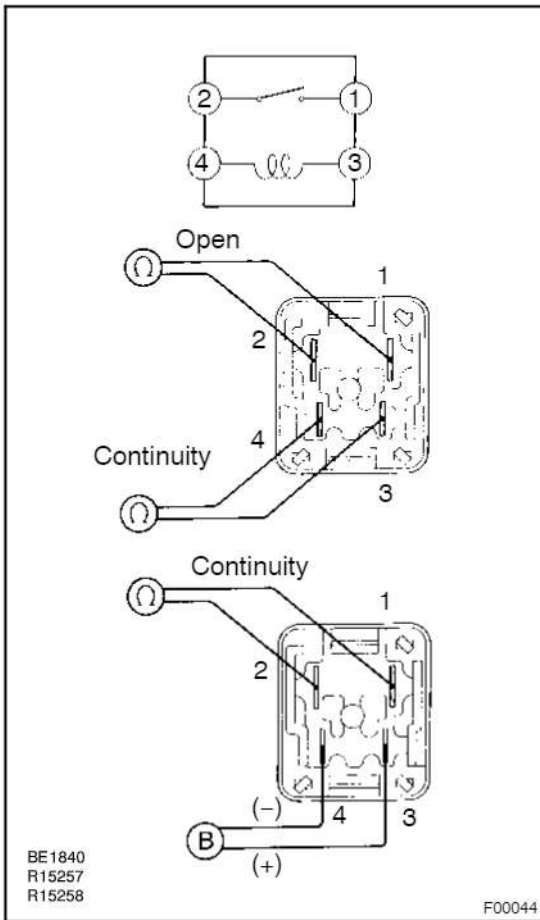
3 Check IG1 No. 1 relay.**PREPARATION:**

Remove IG1 No. 1 relay from engine room J/B.

CHECK:

Check continuity between each pair of terminal of IG1 No. 1 relay.

OK:

Terminals 3 and 4	Continuity
Terminals 1 and 2	Open

CHECK:

- Apply battery voltage between terminals 3 and 4.
- Check continuity between terminals.

OK:

Terminals 1 and 2	Continuity
-------------------	------------

NG**Replace IG1 No. 1 relay.****OK**

Check for open circuit in harness and connector between IG1 No. 1 relay and combination meter (See page IN-35).

4 Check that the ECU connectors are securely connected to the ECU.

NO

Connect the connector to the ECU.

YES

5 Check operation of the ABS warning light (See step 1).

OK

Check and replace ABS & BA & TRC & VSC ECU.

NG

6 Is DTC output?

Check DTC on [page DI-4](#).

YES

Repair circuit indicated by the output code.

NO

7 Check for short circuit in harness and connector between ABS warning light and ABS & BA & TRC & VSC ECU (See [page IN-35](#)).

NG

Repair or replace harness or connector.

OK

Check and repair ABS & BA & TRC & VSC ECU.

cardiagn.com

VSC TRC Warning Light Circuit

CIRCUIT DESCRIPTION

If the ECU stores DTC, the VSC TRC warning light lights on the combination meter.

WIRING DIAGRAM

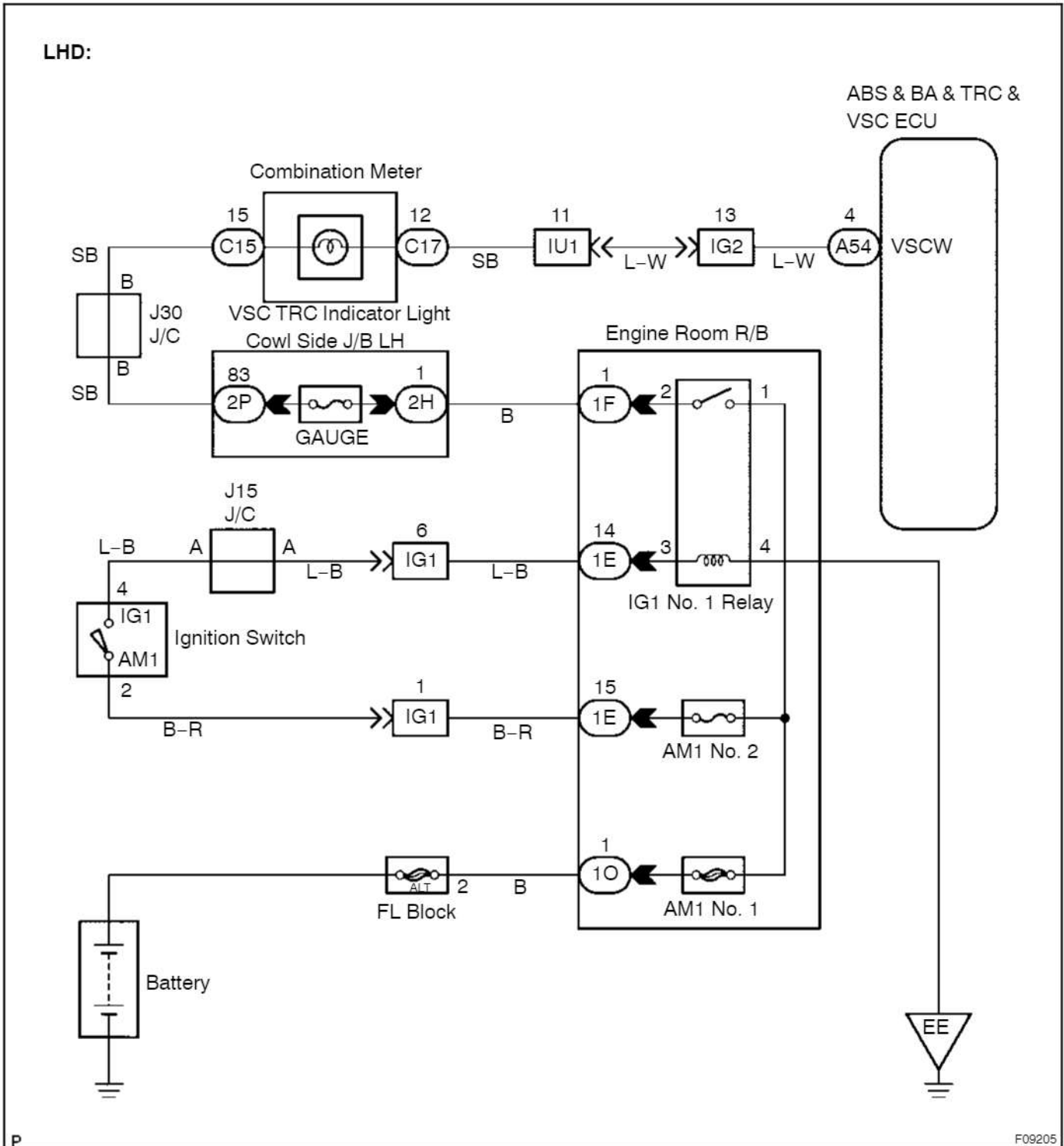

cardiagn.com

RHD:

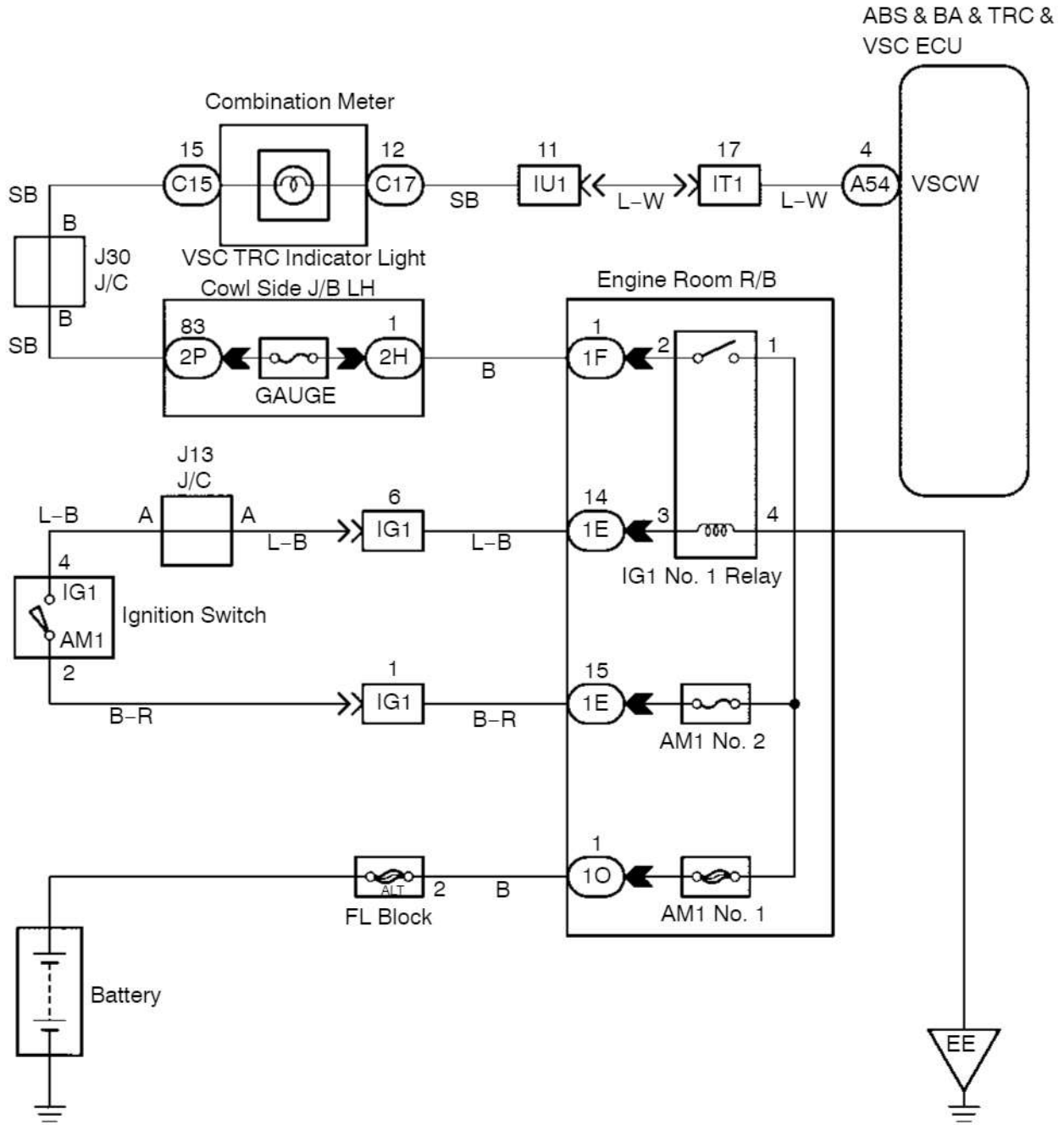

cardiagn.com

P

F09205

INSPECTION PROCEDURE**HINT:**

Troubleshoot in accordance with the chart below for each trouble symptom.

VSC TRC warning light does not light up	*1
VSC TRC warning light remains on	*2

*1: Start the inspection from step 1 in case of using the hand-held tester and start from step 2 in case of not using hand-held tester.

*2: After inspection with step 4, start the inspection from step 5 in case of using the hand-held tester and start from step 6 in case of not using hand-held tester.

1	Check operation of the VSC TRC warning light.
----------	--

PREPARATION:

- (a) Connect the hand-held tester to the DLC3.
- (b) Turn the ignition switch ON and push the hand-held tester main switch ON.
- (c) Select the ACTIVE TEST mode on the hand-held tester.

CHECK:

Check that "ON" and "OFF" of the VSC TRC warning light can be shown on the combination meter on the hand-held tester.



2	Does the warning lights other than VSC TRC warning lights up?
----------	--

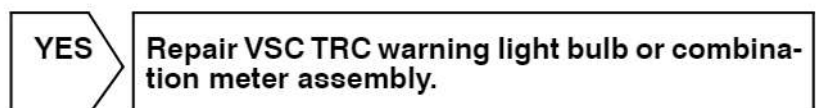

3 Check IG1 No. 1 relay.

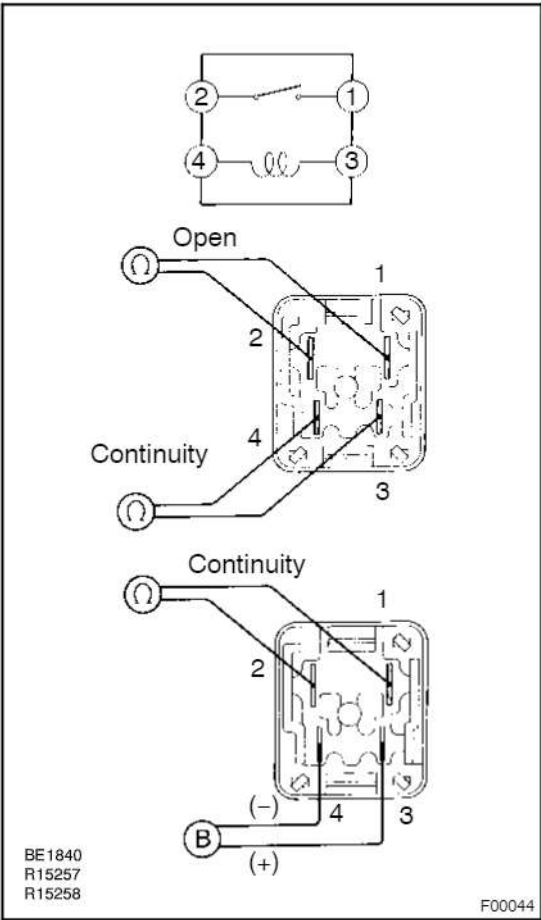

PREPARATION:

Remove IG1 No. 1 relay from engine room J/B.

CHECK:

Check continuity between each pair of terminal of IG1 No. 1 relay.

OK:

Terminals 3 and 4	Continuity
Terminals 1 and 2	Open

CHECK:

- (a) Apply battery voltage between terminals 3 and 4.
- (b) Check continuity between terminals.

OK:

Terminals 1 and 2	Continuity
-------------------	------------

NG Replace IG1 No. 1 relay.

OK

Check for open circuit in harness and connector between IG1 No. 1 relay and combination meter (See page IN-35).

4 Check that the ECU connectors are securely connected to the ECU.

NO

Connect the connector to the ECU.

YES

5 Check operation of the VSC TRC warning light (See step 1).

OK

Check and replace ABS & BA & TRC & VSC ECU.

NG

6 Is DTC output?

Check DTC on [page DI-4](#).

YES

Repair circuit indicated by the output code.

NO

7 Check for short circuit in harness and connector between VSC TRC warning light and ABS & BA & TRC & VSC ECU (See [page IN-35](#)).

NG

Repair or replace harness or connector.

OK

8 Check voltage of the ECU-IG power source.

In case of using the hand-held tester:

PREPARATION:

- (a) Connect the hand-held tester to the DLC3.
- (b) Turn the ignition switch ON and push the hand-held tester main switch ON.
- (c) Select the DATALIST mode on the hand-held tester.

CHECK:

Check the voltage condition output from the ECU displayed on the hand-held tester.

OK:

"Normal" is displayed.

In case of not using the hand-held tester:

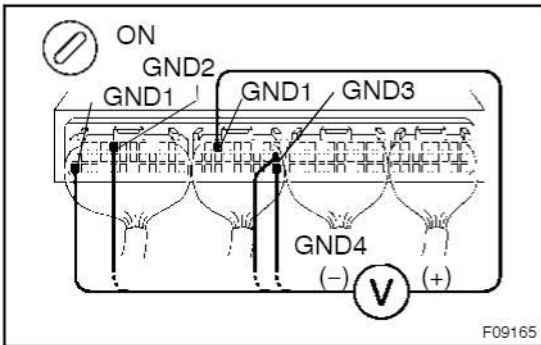

PREPARATION:

Remove ABS & BA & TRAC & VSC ECU with connectors still connected.

CHECK:

- (a) Turn the ignition switch ON.
- (b) Measure voltage between terminals IG1 and GND of ABS & BA & TRAC & VSC ECU connector.

OK:

Voltage: 10 - 14 V

NG

Check and replace harnedd or connector.

OK

Check and repair ABS & BA & TRC & VSC ECU.

BRAKE Warning Light Circuit

CIRCUIT DESCRIPTION

The BRAKE warning light lights up while the brake fluid is insufficient or an abnormality occurs in the hydraulic brake booster and EBD is abnormally.

WIRING DIAGRAM

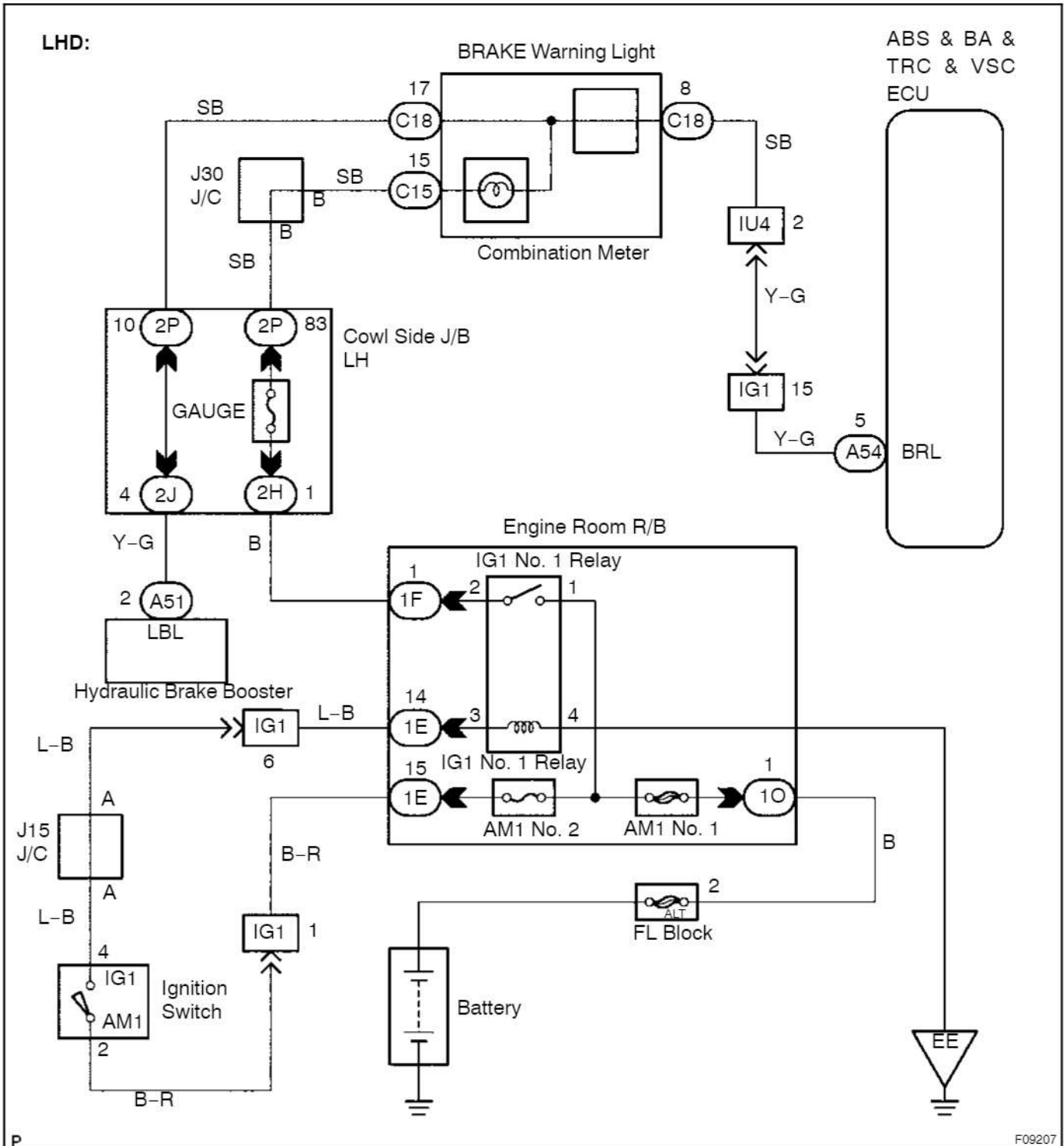

cardiagn.com

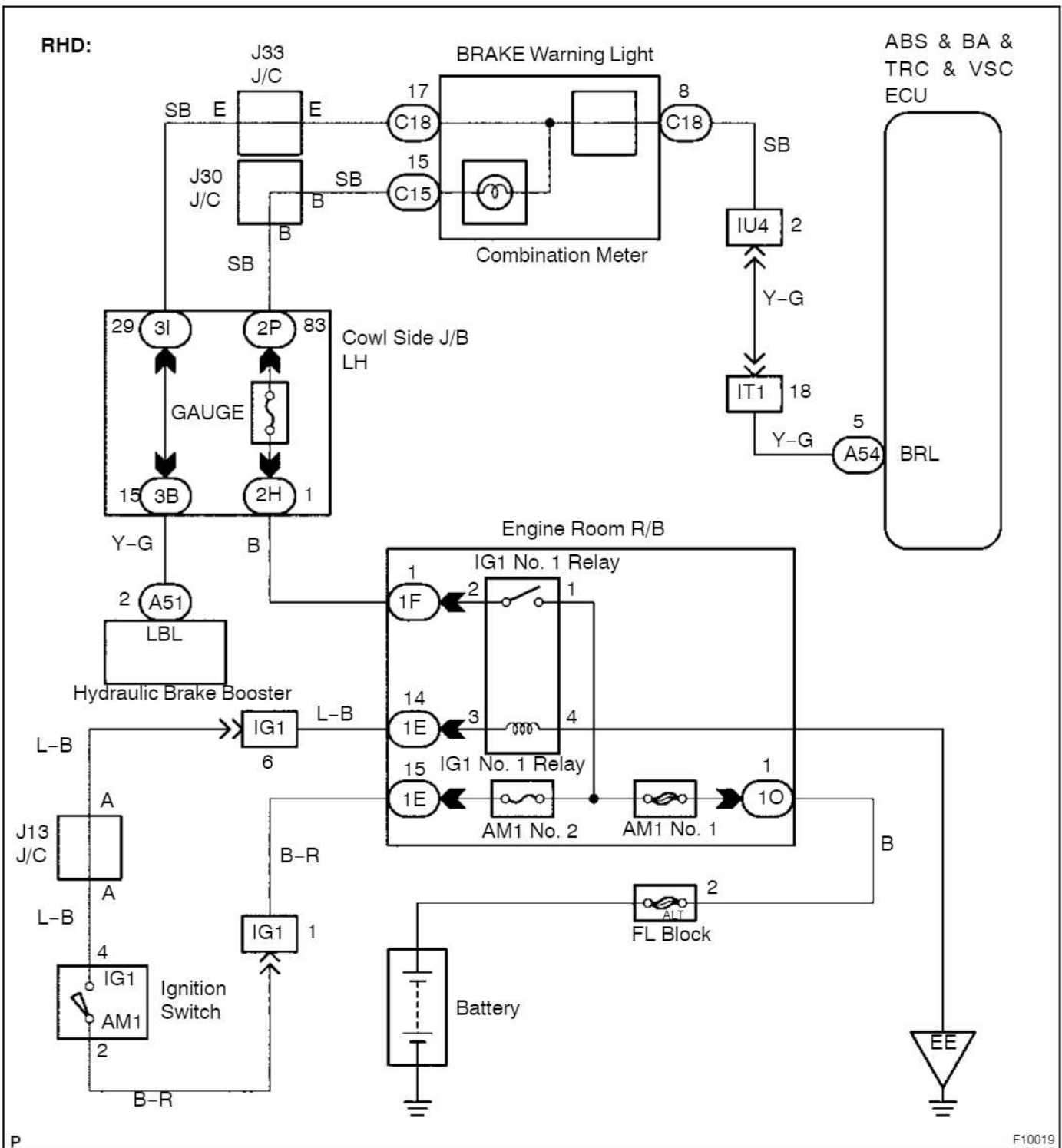

INSPECTION PROCEDURE

1 Check parking brake switch circuit (See page BE-4).

NG

Repair or replace parking brake switch circuit.

OK

2 Check brake fluid level warning switch circuit (See page BE-4).

NG

Repair or replace brake fluid level warning switch circuit.

OK

3 Is DTC output for ABS?

YES

Repair circuit indicated by the output code.

NO

4 Does the warning lights other than BRAKE warning lights up?

YES

Go to step 6.

NO

5 Check IG1 No. 1 relay.

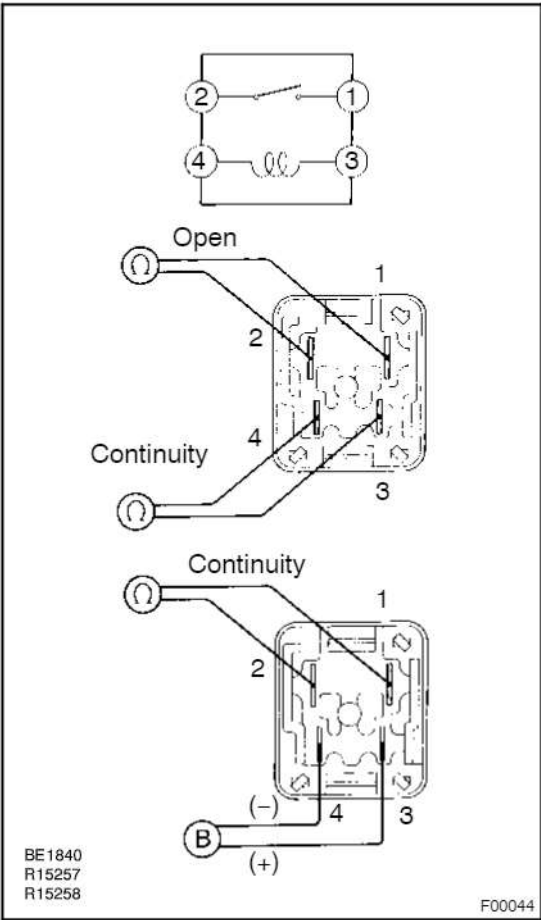

PREPARATION:

Remove IG1 No. 1 relay from engine room J/B.

CHECK:

Check continuity between each pair of terminal of IG1 No. 1 relay.

OK:

Terminals 3 and 4	Continuity
Terminals 1 and 2	Open

CHECK:

- (a) Apply battery voltage between terminals 3 and 4.
- (b) Check continuity between terminals.

OK:

Terminals 1 and 2	Continuity
-------------------	------------

NG Replace IG1 No. 1 relay.

OK

Check for open circuit in harness and connector between IG1 No. 1 relay and combination meter (See page IN-35).

6 Check BRAKE warning light.

Open circuit in the combination meter (See page BE-1).

NG Repair brake warning light bulb or combination meter assembly.

OK

- | | |
|----------|--|
| 7 | Check for short circuit in harness and connector between brake warning light and ABS & BA & TRC & VSC ECU (See page IN-35). |
|----------|--|

NG

Repair or replace harness or connector.

OK

- | | |
|----------|--|
| 8 | Check voltage of the ECU-IG power source. |
|----------|--|

In case of using the hand-held tester:

PREPARATION:

- (a) Connect the hand-held tester to the DLC3.
- (b) Turn the ignition switch ON and push the hand-held tester main switch ON.
- (c) Select the DATALIST mode on the hand-held tester.

CHECK:

Check the voltage condition output from the ECU displayed on the hand-held tester.

OK:

"Normal" is displayed.

In case of not using the hand-held tester:

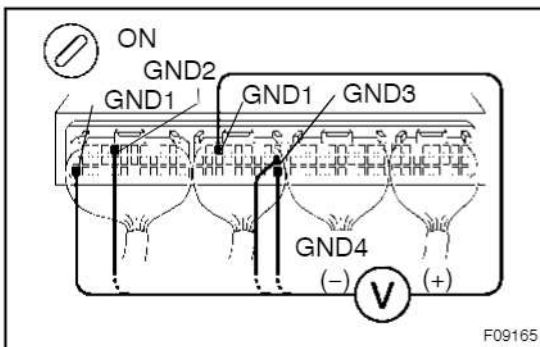
**PREPARATION:**

Remove ABS & BA & TRC & VSC ECU with connectors still connected.

CHECK:

- (a) Turn the ignition switch ON.
- (b) Measure voltage between terminals IG1 and GND of ABS & BA & TRC & VSC ECU connector.

OK:

Voltage: 10 - 14 V

NG

Check and replace harnedd or connector.

OK

Check and repair ABS & BA & TRC & VSC ECU.

SLIP Indicator Light Circuit

CIRCUIT DESCRIPTION

The SLIP indicator blinks during VSC operation.

WIRING DIAGRAM

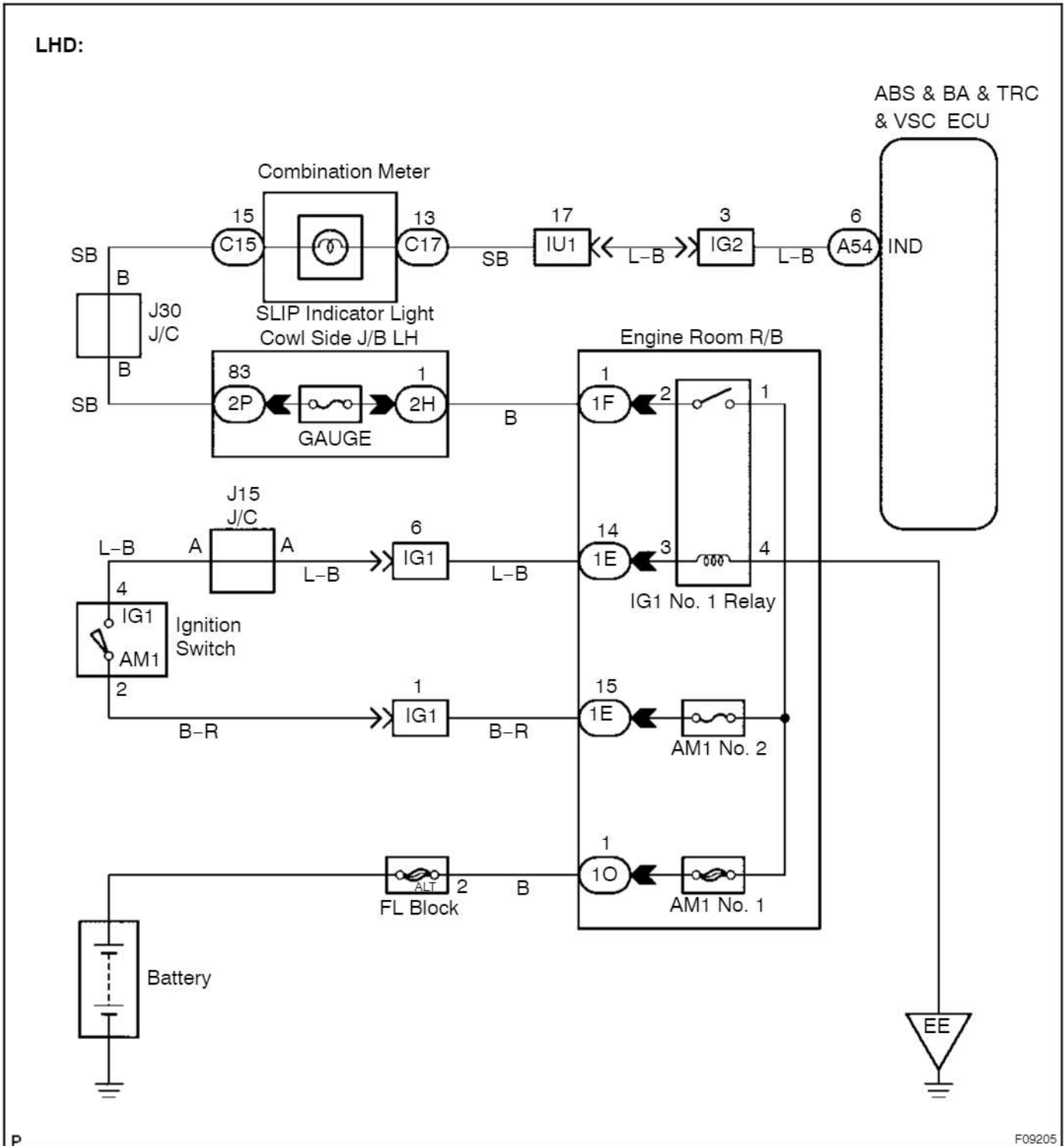

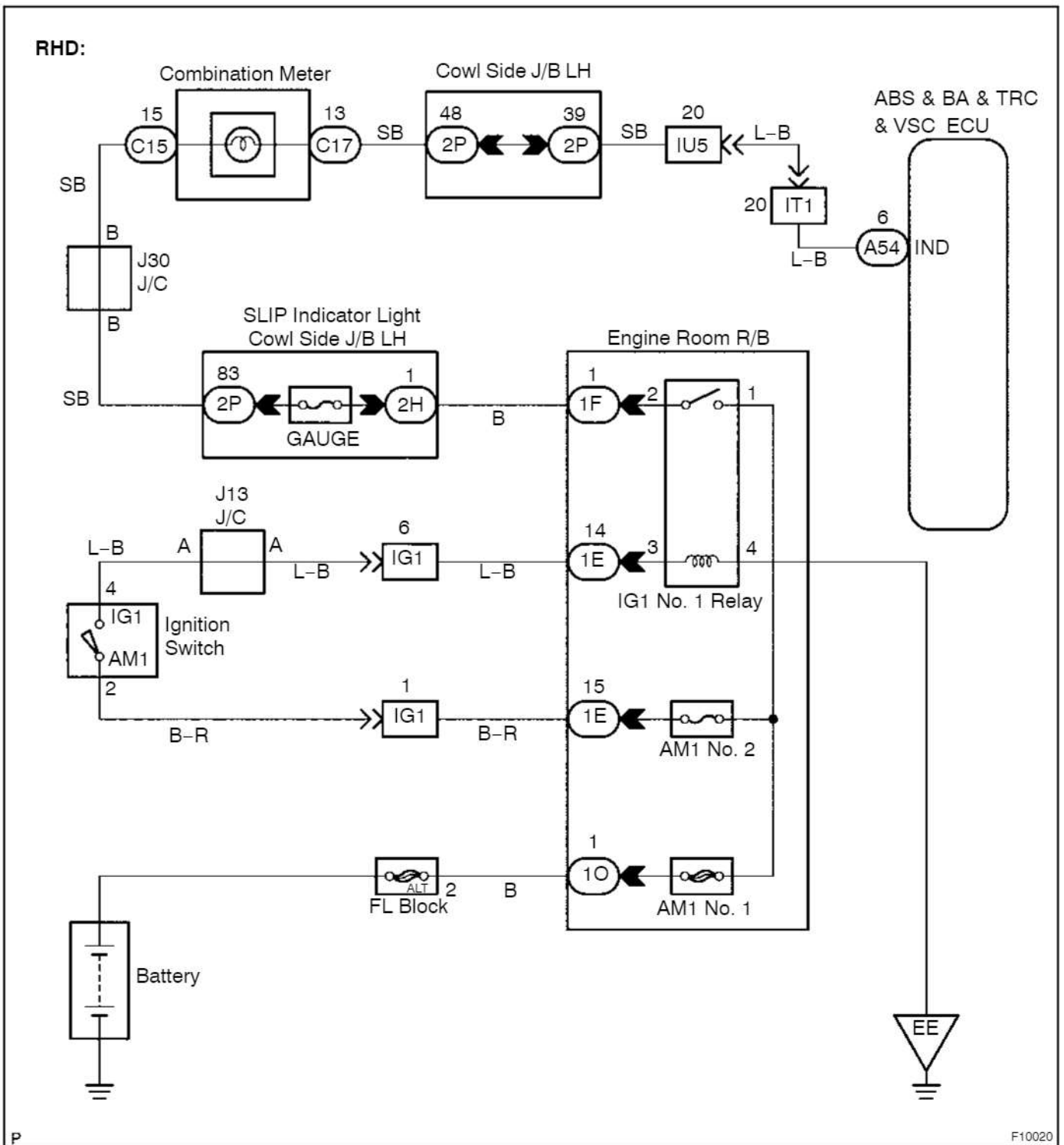

cardiagn.com

INSPECTION PROCEDURE

1 Does the warning lights other than SLIP indicator lights up?

YES Go to step 3.

NO

2 Check IG1 No. 1 relay.

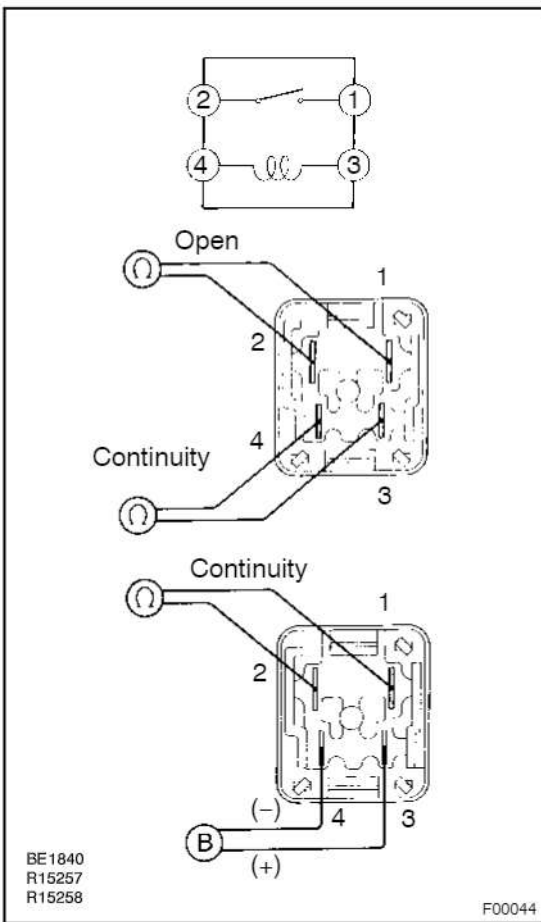

PREPARATION:

Remove IG1 No. 1 relay from engine room J/B.

CHECK:

Check continuity between each pair of terminal of IG1 No. 1 relay.

OK:

Terminals 3 and 4	Continuity
Terminals 1 and 2	Open

CHECK:

- (a) Apply battery voltage between terminals 3 and 4.
- (b) Check continuity between terminals.

OK:

Terminals 1 and 2	Continuity
-------------------	------------

NG Replace IG1 No. 1 relay.

OK

Check for open circuit in harness and connector between IG1 No. 1 relay and combination meter (See page IN-35).

3 Check SLIP indicator light.

Open circuit in the combination meter (See page BE-1).

NG**Repair SLIP indicator light bulb or combination meter assembly.****OK****4 Check for short circuit in harness and connector between SLIP indicator light and ABS & BA & TRC & VSC ECU (See page IN-35).****NG****Repair or replace harness or connector.****OK****Check and repair ABS & BA & TRC & VSC ECU.**

ACTIVE TRC Indicator Light Circuit

CIRCUIT DESCRIPTION

The ACTIVE TRC indicator blinks during TRC operation.

WIRING DIAGRAM

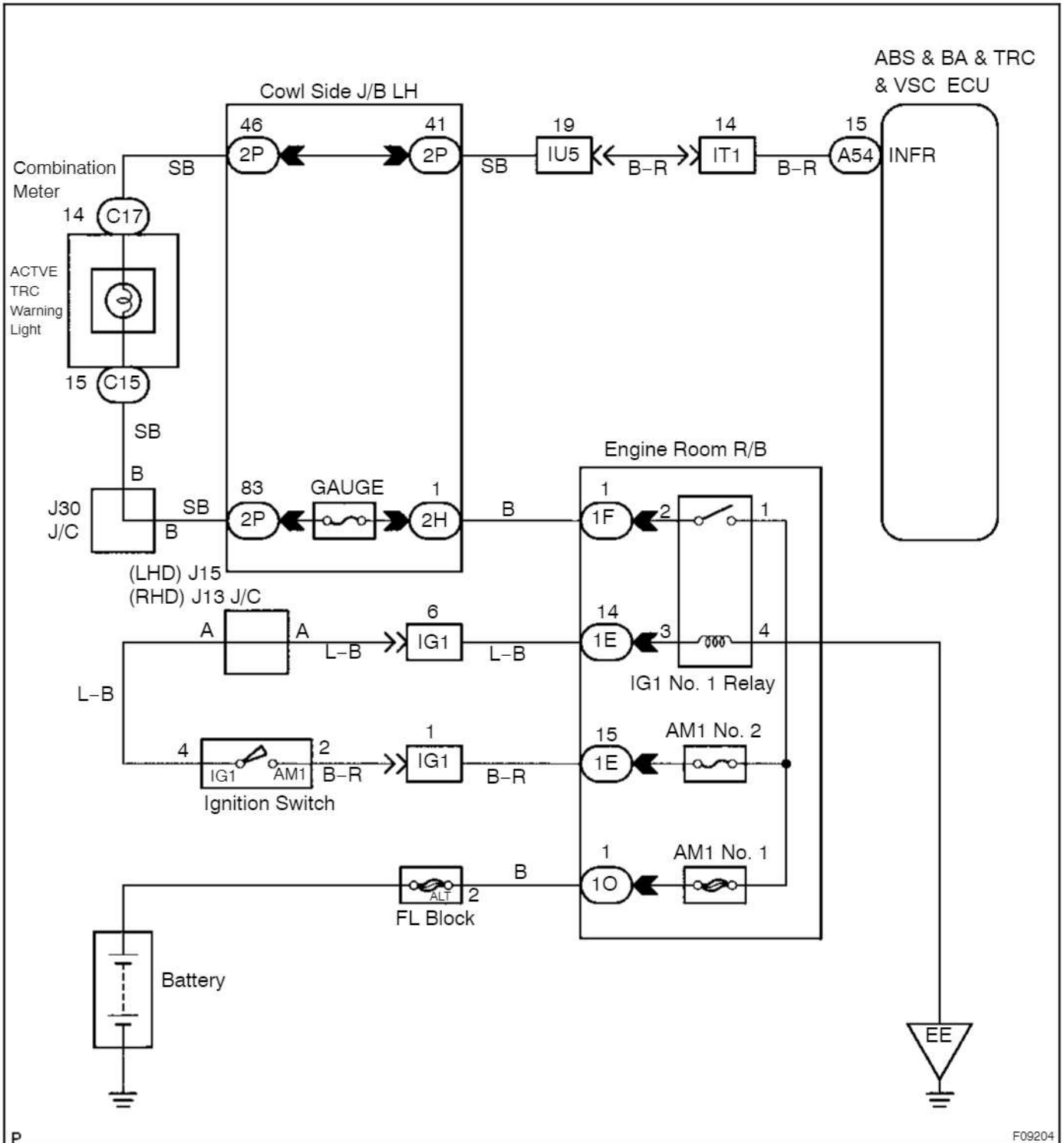

P

F09204

INSPECTION PROCEDURE

1 Does the warning lights other than ACTIVE TRC indicator lights up?

YES

Go to step 3.

NO

2 Check IG1 No. 1 relay.

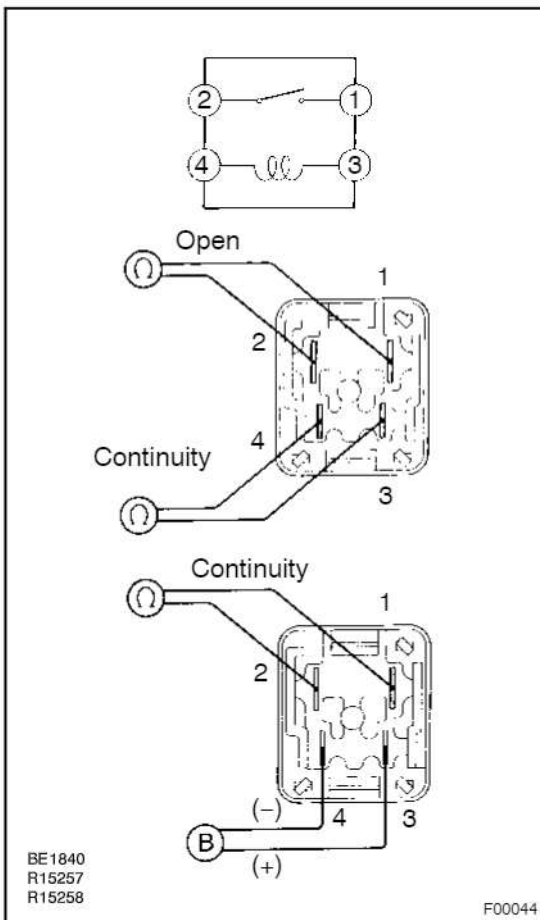
**PREPARATION:**

Remove IG1 No. 1 relay from engine room J/B.

CHECK:

Check continuity between each pair of terminal of IG1 No. 1 relay.

OK:

Terminals 3 and 4	Continuity
Terminals 1 and 2	Open

CHECK:

- Apply battery voltage between terminals 3 and 4.
- Check continuity between terminals.

OK:

Terminals 1 and 2	Continuity
-------------------	------------

NG

Replace IG1 No. 1 relay.

OK

Check for open circuit in harness and connector between IG1 No. 1 relay and combination meter (See page IN-35).

3	Check ACTIVE TRC indicator light.
----------	--

Open circuit in the combination meter (See page BE-1).

NG	Repair ACTIVE TRC indicator light bulb or combination meter assembly.
-----------	--

OK

4	Check for short circuit in harness and connector between ACTIVE TRC indicator light and ABS & BA & TRC & VSC ECU (See page IN-35).
----------	---

NG	Repair or replace harness or connector.
-----------	--

OK

Check and repair ABS & BA & TRC & VSC ECU.

cardiagn.com

VSC OFF Indicator Light, Center Diff Lock Switch Circuit

CIRCUIT DESCRIPTION

This is the VSC control main switch. When the center differential is locked, VSC control goes off and the VSC OFF indicator lights up. Also, light the VSC OFF indicator light is "ON" when the VSC system is at the fail safe control.

WIRING DIAGRAM

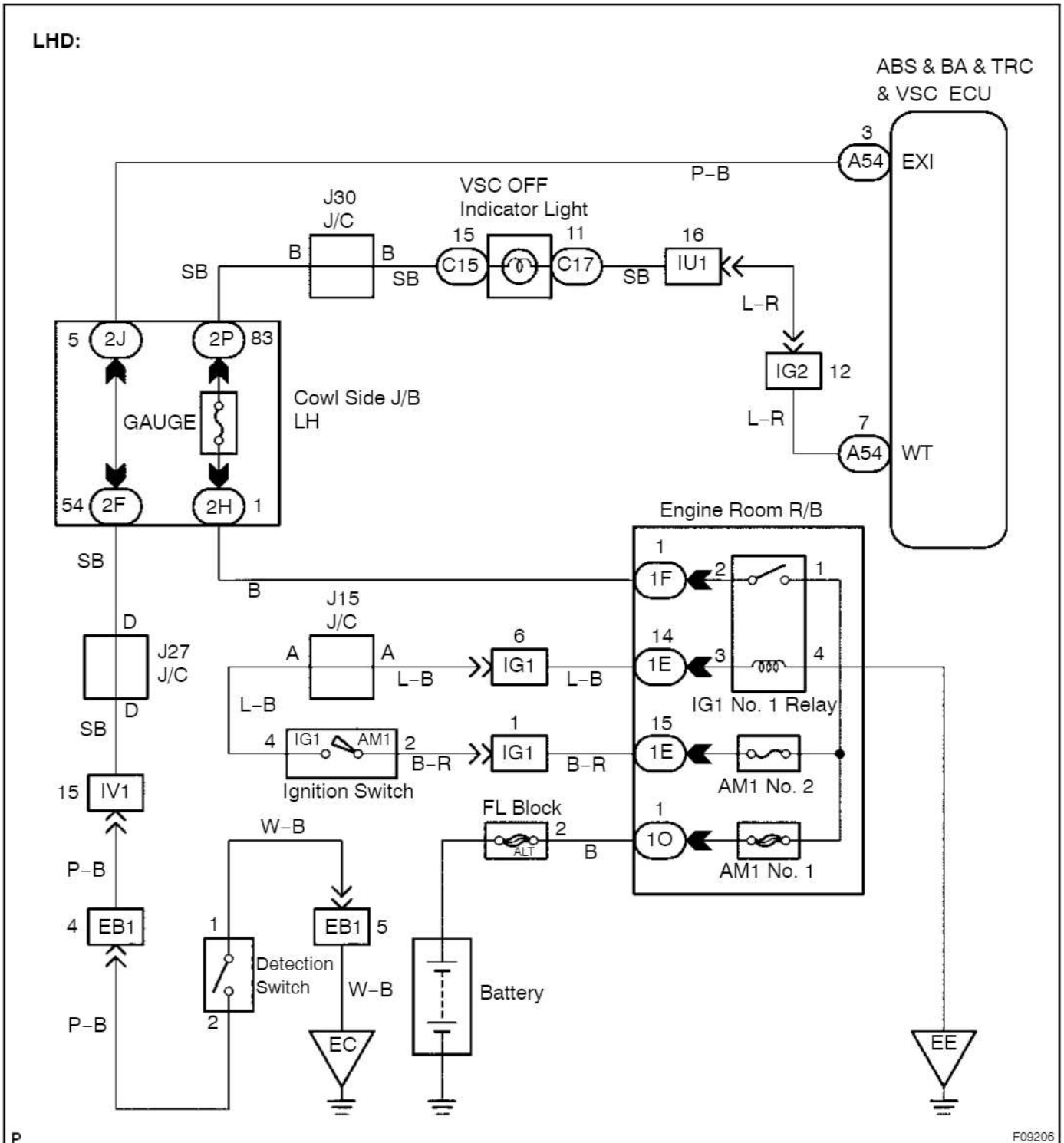

cardiagn.com

RHD:

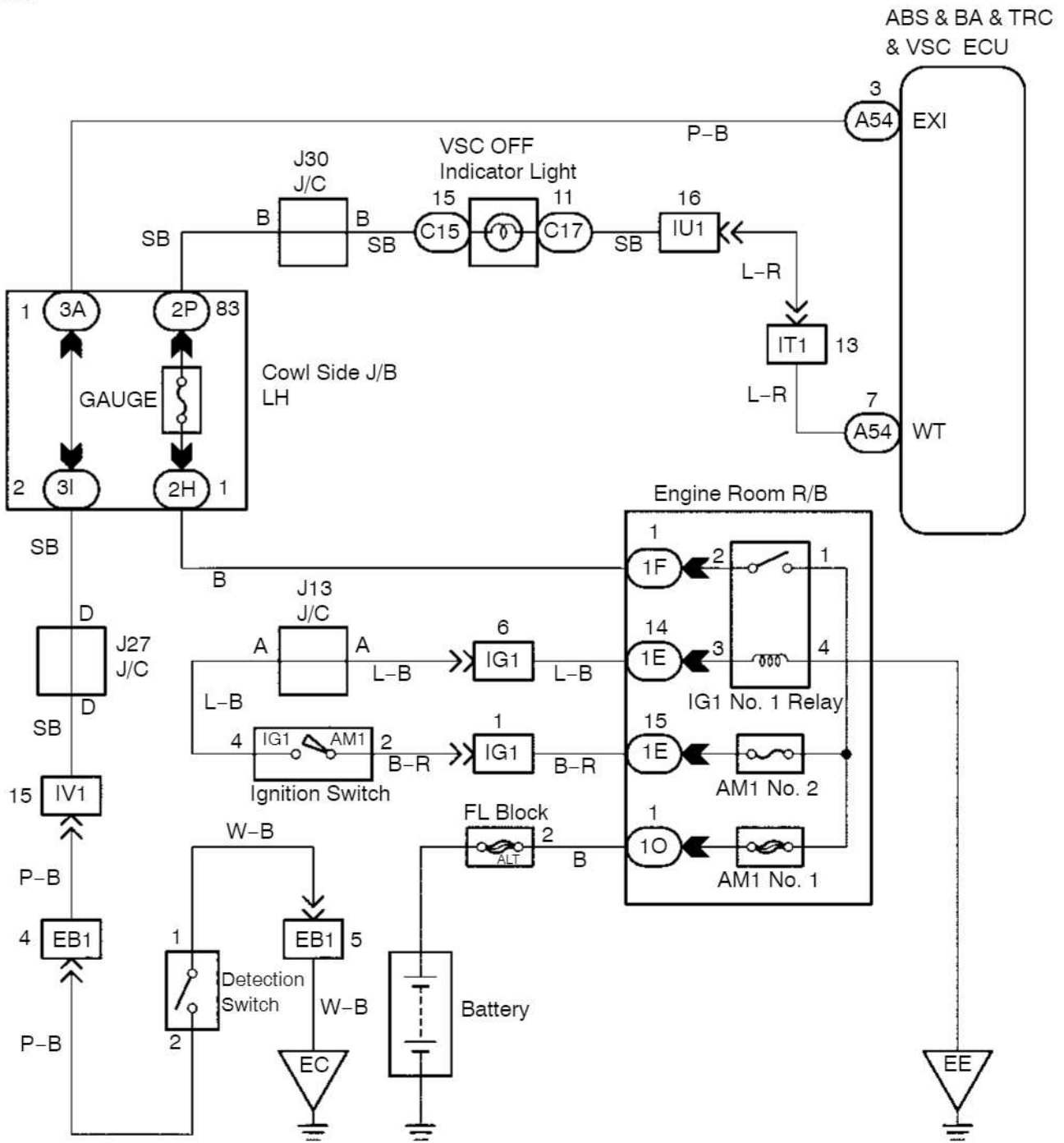

cardiagn.com

P

F09206

INSPECTION PROCEDURE**HINT:**

Start the inspection from step 1 in case of using the hand-held tester and start from step 2 in case of not using the hand-held tester.

1	Check operation of the VSC OFF indicator light.
----------	--

PREPARATION:

- (a) Connect the hand-held tester to the DLC3.
- (b) Turn the ignition switch ON and push the hand-held tester main switch ON.
- (c) Select the ACTIVE TEST mode on the hand-held tester.

CHECK:

Check that "ON" and "OFF" of the VSC OFF indicator light can be shown on the combination meter with the hand-held tester.



2	Is DTC output for VSC?
----------	-------------------------------



3	Does the warning lights other than VSC OFF indicator lights up?
----------	--

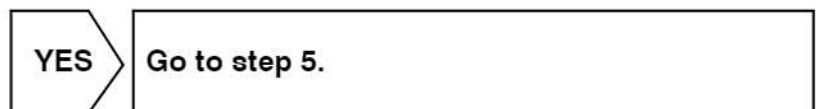

4 Check IG1 No. 1 relay.

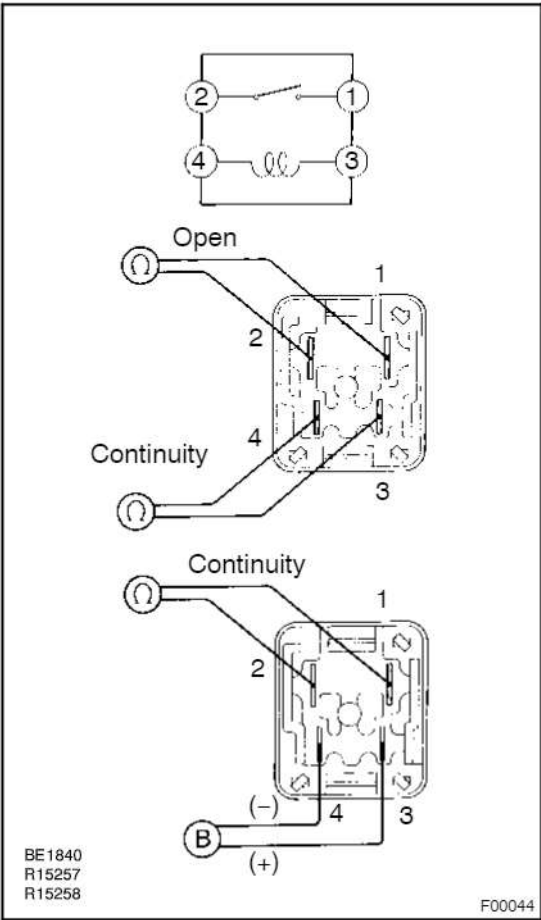

PREPARATION:

Remove IG1 No. 1 relay from engine room J/B.

CHECK:

Check continuity between each pair of terminal of IG1 No. 1 relay.

OK:

Terminals 3 and 4	Continuity
Terminals 1 and 2	Open

CHECK:

- (a) Apply battery voltage between terminals 3 and 4.
- (b) Check continuity between terminals.

OK:

Terminals 1 and 2	Continuity
-------------------	------------

NG Replace IG1 No. 1 relay.

OK

Check for open circuit in harness and connector between IG1 No. 1 relay and combination meter (See page IN-35).

5 Check VSC OFF indicator light.

Open circuit in the combination meter (See page BE-1).

NG Repair VSC OFF indicator light bulb or combination meter assembly.

OK

- 6** Check for short circuit in harness and connector between VSC OFF indicator light and ABS & BA & TRC & VSC ECU (See page IN-35).

NG

Repair or replace harness or connector.

OK

- 7** Check for open and short circuit in harness and connector between detection switch and ABS & BA & TRC & VSC ECU (See page IN-35).

NG

Repair or replace harness or connector.

OK

- 8** Check detection switch (detection switch remains on).

NG

Check and repair detection switch (See Pub No. RM616E on page TR-55).

OK

Check and repair ABS & BA & TRC & VSC ECU.

Brake Warning, VSC Buzzer Circuit

CIRCUIT DESCRIPTION

The brake warning, VSC buzzer sounds while the accumulator pressure is abnormally low or an abnormality causing low fluid pressure occurs VSC is activated.

WIRING DIAGRAM

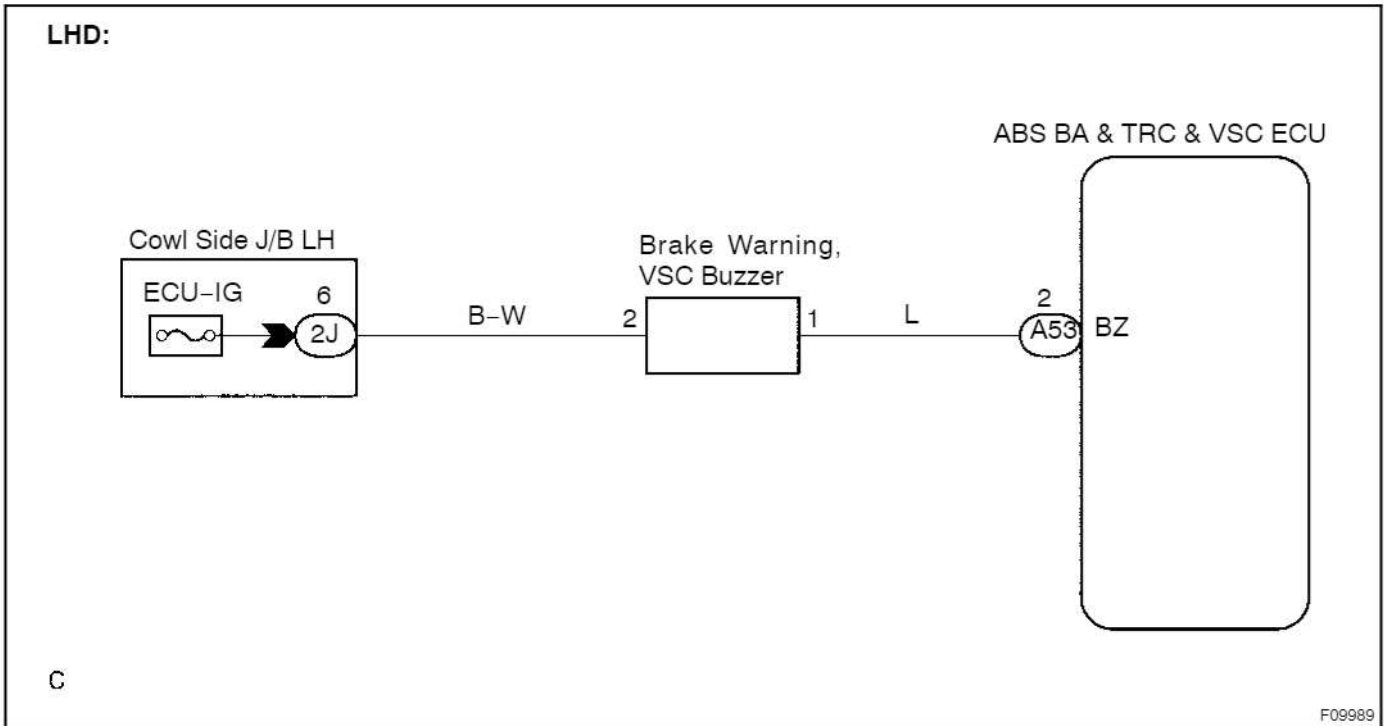

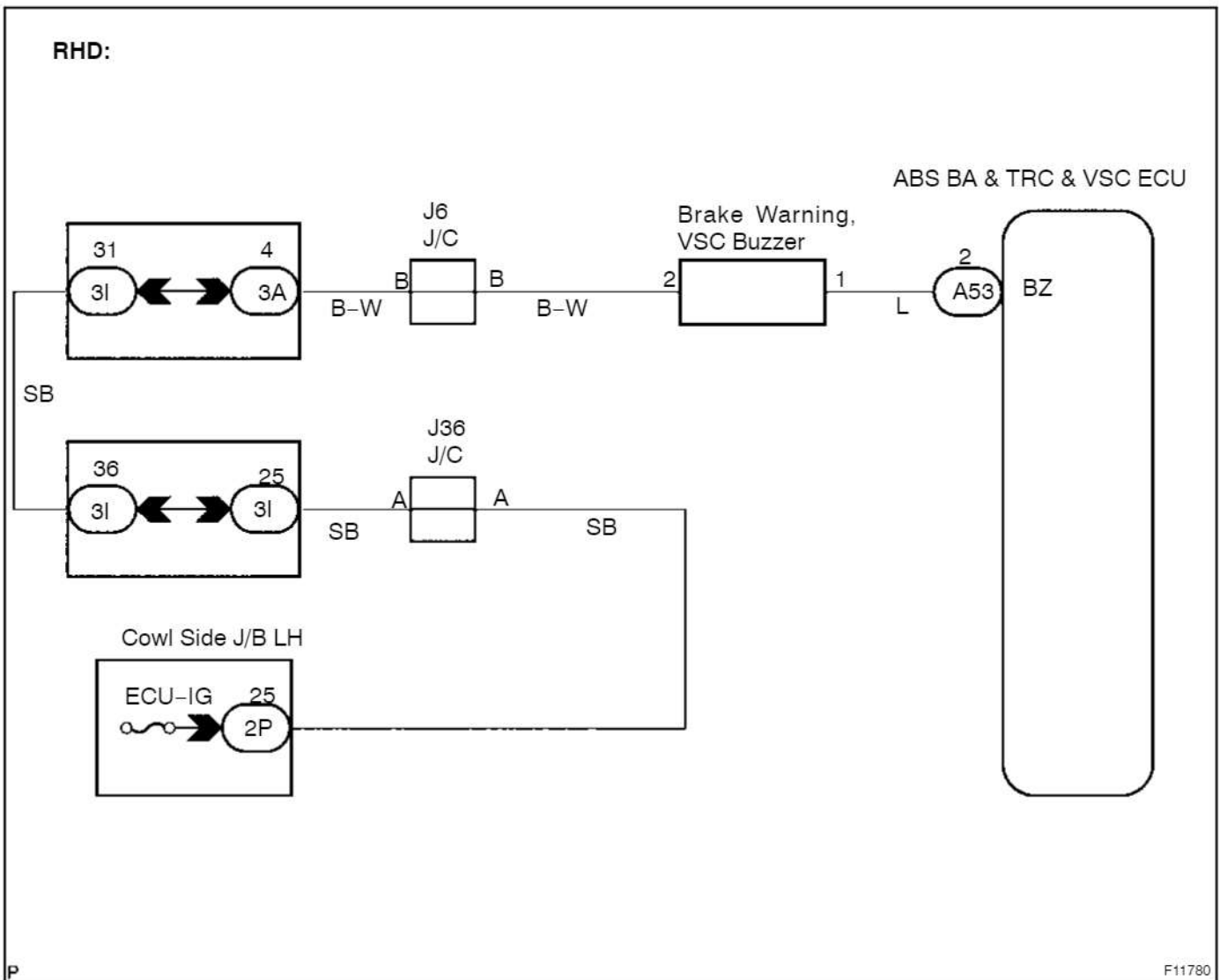

INSPECTION PROCEDURE

HINT:

Start the inspection from step 1 in case of using the hand-held tester and start from step 2 in case of not using the hand-held tester.

1	Check operation of the brake warning, VSC buzzer.
----------	--

PREPARATION:

- (a) Connect the hand-held tester to the DLC3.
- (b) Turn the ignition switch ON and push the hand-held tester main switch ON.
- (c) Select the ACTIVE TEST mode on the hand-held tester.

CHECK:

Check that brake warning, VSC buzzer sounds "ON" and "OFF" with the hand-held tester.

OK

Check and replace ABS & BA & TRC & VSC ECU.

NG

2 Check brake warning, VSC buzzer.

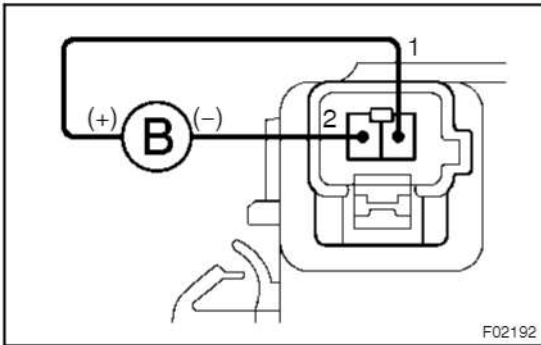

PREPARATION:

Disconnect the brake warning, VSC buzzer connector.

CHECK:

Apply battery voltage to the terminals 1 and 2 of brake warning, VSC buzzer connector, check that the brake warning, VSC buzzer sounds.

NG

Replace brake warning, VSC buzzer.

OK

3 Check for open and short circuit in harness and connector between ABS & BA & TRC & VSC ECU and brake warning, VSC buzzer (See page IN-35).

NG

Repair or replace harness or connector.

OK

Check and replace ABS & BA & TRC & VSC ECU.

Tc Terminal Circuit

CIRCUIT DESCRIPTION

Connecting terminals Tc and E₁ of the check connector causes the ECU to display the DTC by flashing the ABS warning light and VSC TRC warning light.

WIRING DIAGRAM

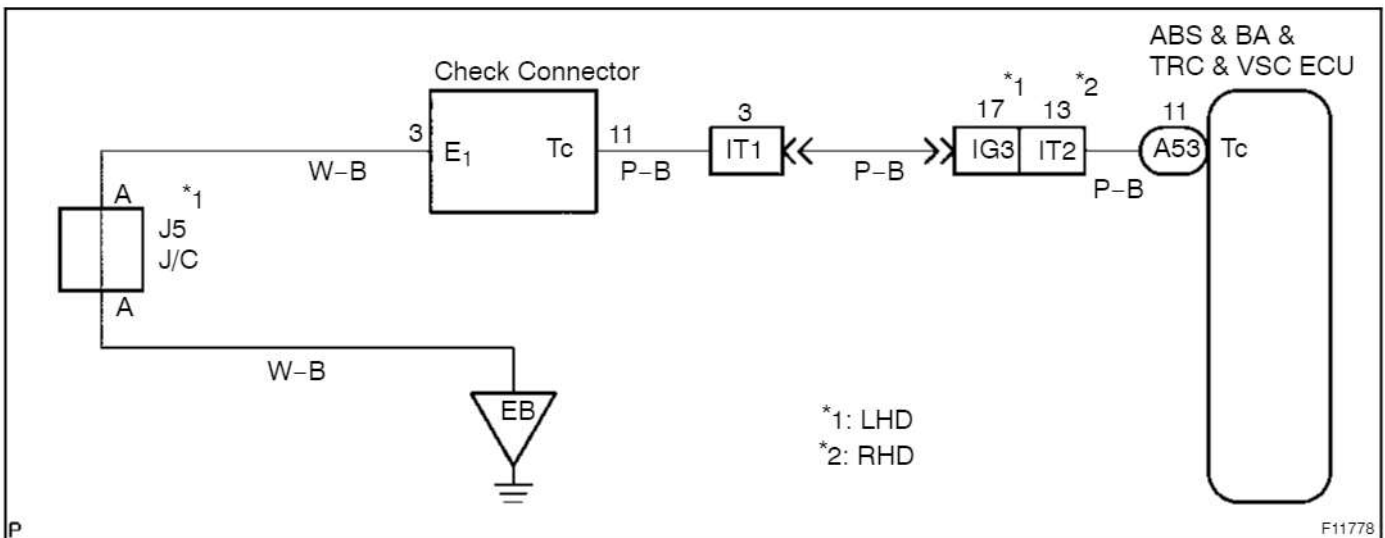

INSPECTION PROCEDURE

- 1 Check voltage between terminals Tc and E₁ of check connector.

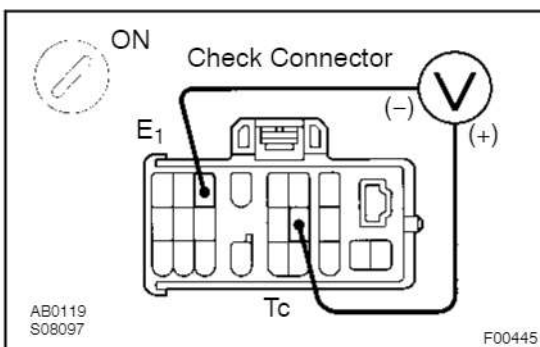

CHECK:

- Turn ignition switch ON.
- Measure voltage between terminals Tc and E₁ of check connector.

OK:

Voltage: 10 - 14 V

OK

If ABS warning light does not blink even after Tc and E₁ have been connected, the ECU may be defective.

NG

2 IG switch OFF, and check for open and short circuit in harness and connector between ABS & BA & TRC & VSC ECU and check connector, check connector and body ground ([See page IN-35](#)).

NG

Repair or replace harness or connector.

OK

Check and replace ABS & BA & TRC & VSC ECU.

Ts Terminal Circuit

CIRCUIT DESCRIPTION

The sensor check circuit detects abnormalities in the speed sensor signal which cannot be detected by the DTC check.

Connecting terminals Ts and E₁ of the check connector or Tc starts the check.

WIRING DIAGRAM

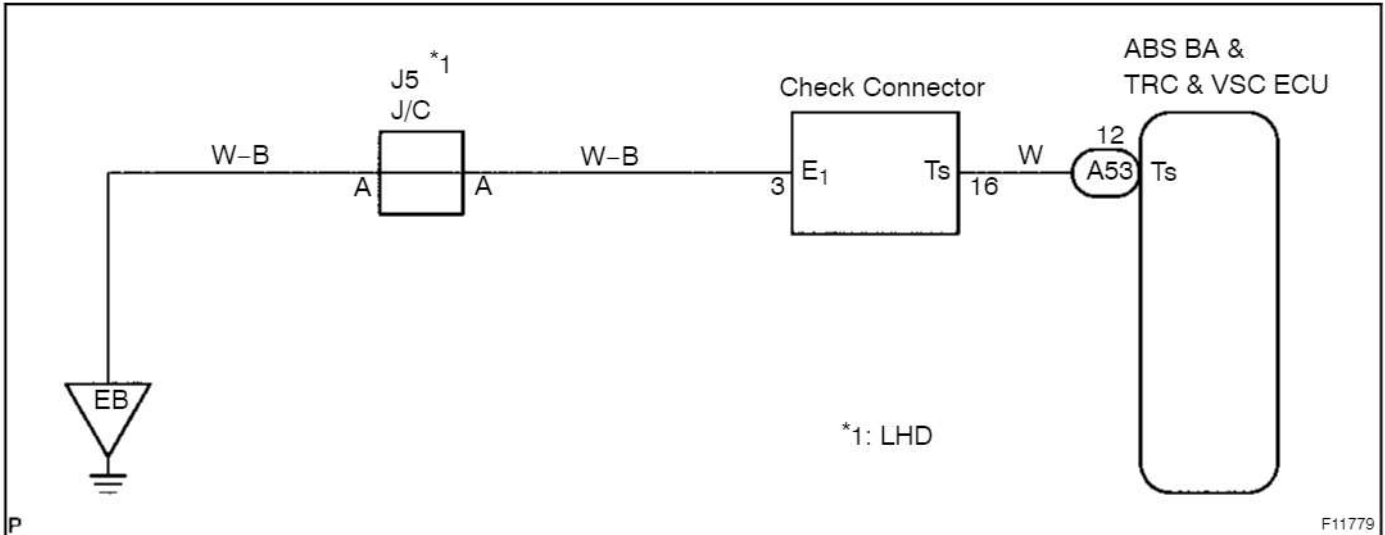

INSPECTION PROCEDURE

- 1 Check voltage between terminals Ts and E₁ of check connector.

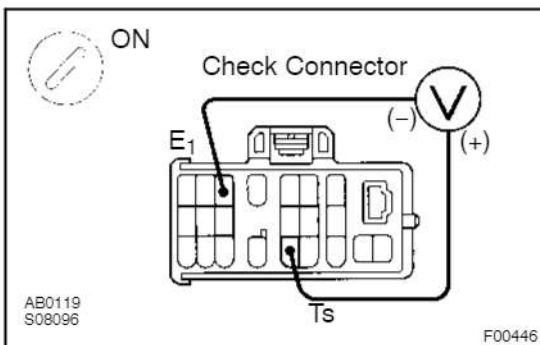

CHECK:

- Turn the ignition switch ON.
- Measure voltage between terminals Ts and E₁ of check connector.

OK:

Voltage: 10 - 14 V

OK

If ABS warning light does not blink even after Ts and E₁ have been connected, the ECU may be defective.

NG

2 IG switch OFF, and check for open and short circuit in harness and connector between ABS & BA & TRC & VSC ECU and check connector, check connector and body ground ([See page IN-35](#)).

NG

Repair or replace harness or connector.

OK

Check and replace ABS & BA & TRC & VSC ECU.

Check for Fluid Leakage

Check for fluid leakage from actuator or hydraulic lines.

LHD:

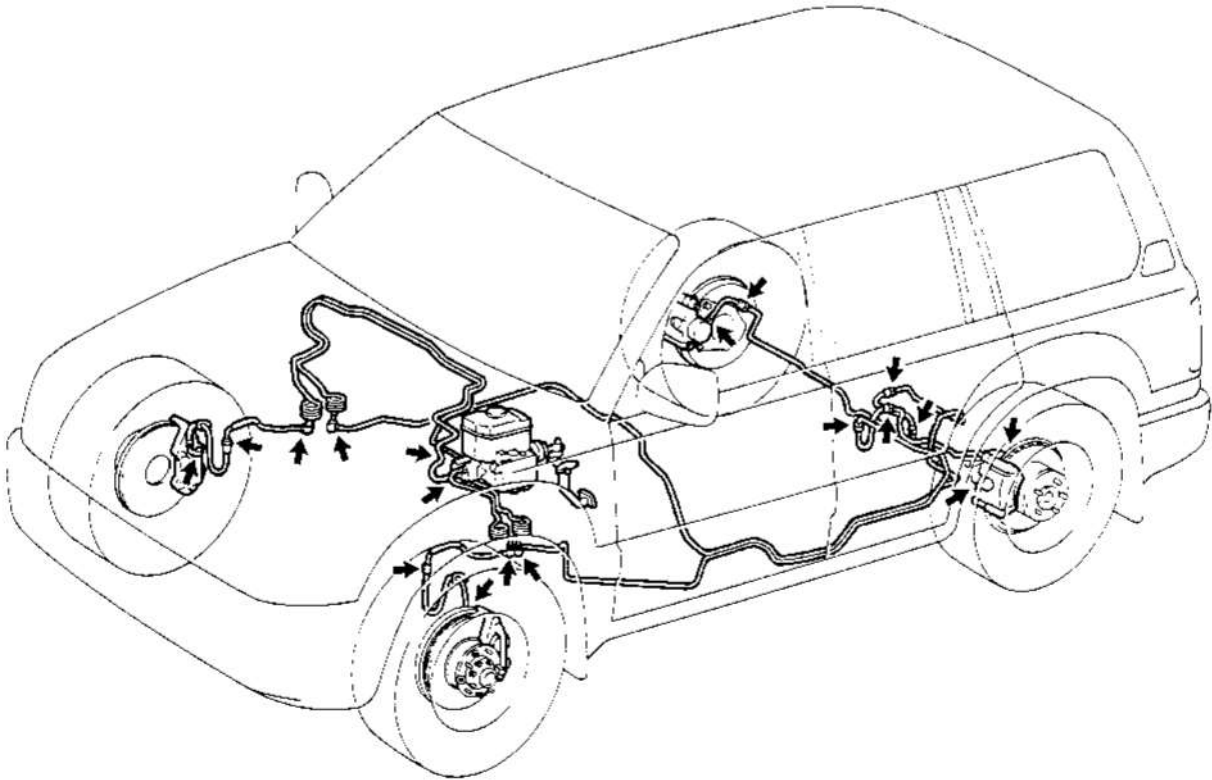

RHD:

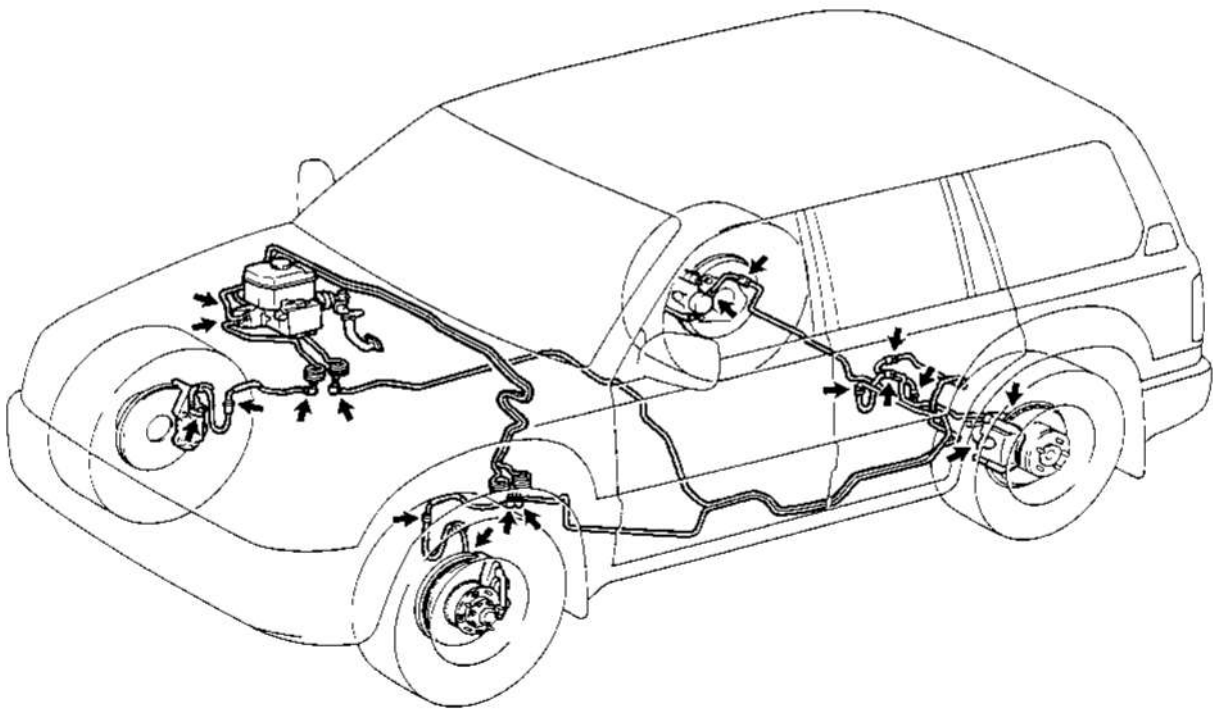

Z

F10041

FRONT DIFFERENTIAL CARRIER (Independent Front Suspension) COMPONENTS

SA159-01

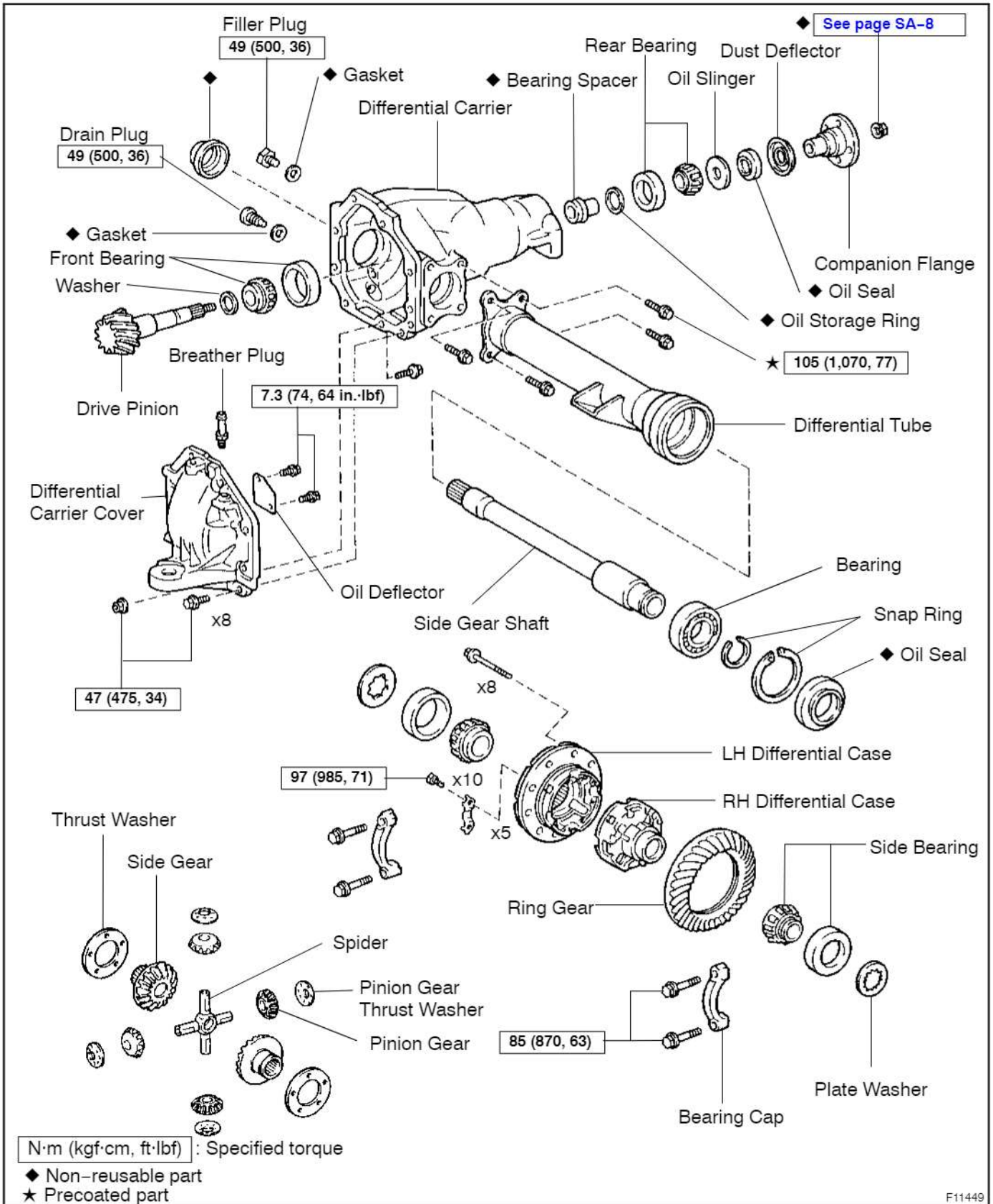

cardiagn.com

F11449

DISASSEMBLY

1. REMOVE DIFFERENTIAL CARRIER COVER

- Remove the 9 bolts and nut from the carrier cover.
- Using a brass bar and hammer, separate the cover from carrier.
- Remove the breather plug from the differential carrier cover.
- Remove the 2 bolts and oil deflector from the differential carrier cover.

2. SET DIFFERENTIAL CARRIER TO OVERHAUL STAND, ETC.

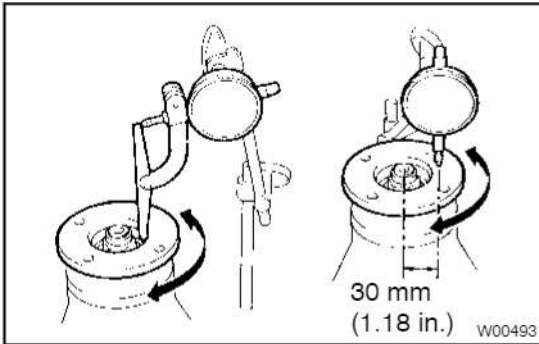

3. CHECK RUNOUT OF COMPANION FLANGE

Using a dial indicator, measure the vertical and lateral runout of the companion flange.

Maximum: 0.09 mm (0.0035 in.)

If the runout is greater than the maximum, replace the companion flange.

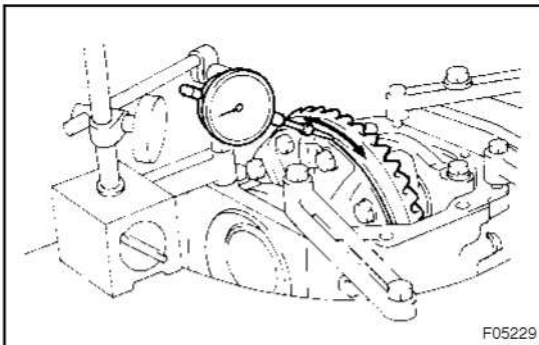

4. CHECK RING GEAR RUNOUT

Using a dial indicator, measure the ring gear runout.

Maximum runout: 0.07 mm (0.0028 in.)

If the runout is greater than the maximum, replace the ring gear and drive pinion as a set.

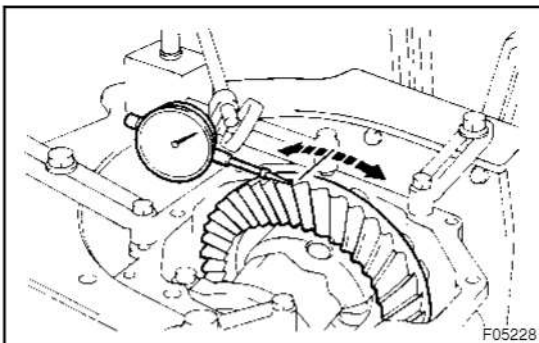

5. CHECK RING GEAR BACKLASH

Using a dial indicator, while holding the drive pinion flange measure the ring gear backlash.

Backlash: 0.13 - 0.18 mm (0.0051 - 0.0071 in.)

HINT:

Measure at 3 or more places on the circumference of the ring gear.

If the backlash is not within the specification, adjust the backlash.

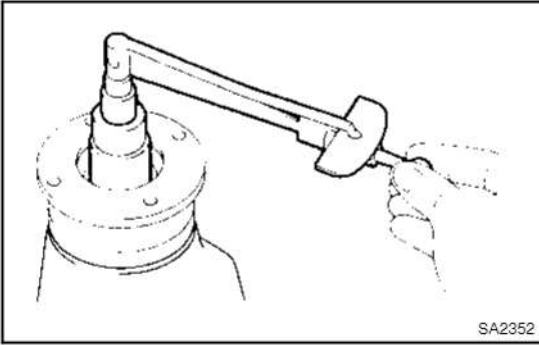

6. MEASURE DRIVE PINION PRELOAD

Using a torque wrench, measure the drive pinion preload using the backlash of the drive pinion and ring gear.

Preload (at starting):

0.5 – 0.8 N·m (5 – 8 kgf·cm, 4.3 – 6.9 in.·lbf)

7. CHECK TOTAL PRELOAD

Using a torque wrench, measure the total preload.

Total preload (at starting):

Drive pinion preload plus

0.4 – 0.6 N·m (4 – 6 kgf·cm, 3.5 – 5.2 in.·lbf)

If necessary, disassemble and inspect the differential.

8. INSPECT TOOTH CONTACT BETWEEN RING GEAR AND DRIVE PINION (See page SA-8)

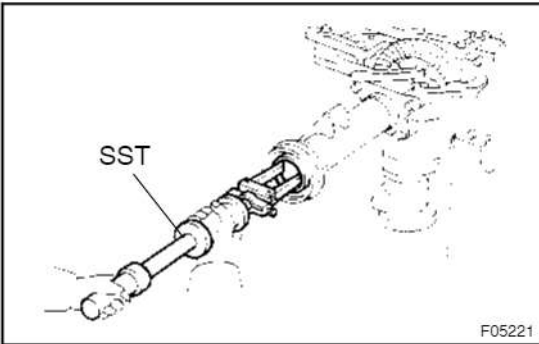

9. REMOVE SIDE GEAR SHAFT OIL SEALS

Using SST, remove the 2 side gear shaft oil seals.

SST 09308-00010

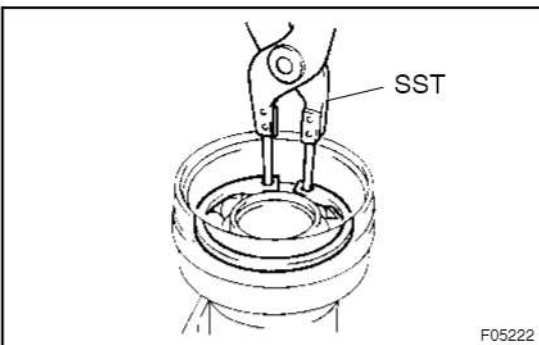

10. REMOVE DIFFERENTIAL TUBE ASSEMBLY

(a) Using SST, remove the snap ring.

SST 09350-30020 (09350-07060)

(b) Using a snap ring expander, remove the snap ring.

(c) Remove the 4 bolts and differential tube with side gear shaft from the differential carrier.

(d) Remove the side gear shaft from the differential tube.

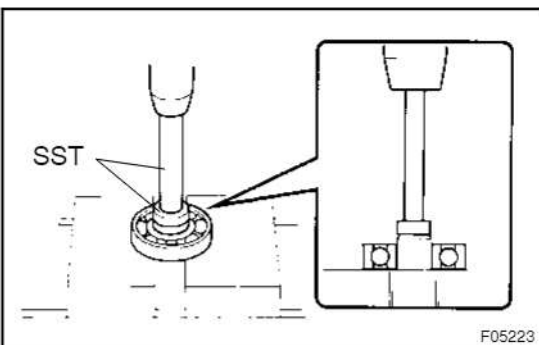

11. REMOVE SIDE GEAR BEARING

Using SST and a press, remove the bearing from side gear shaft.

SST 09950-60010 (09951-00410), 09950-70010 (09951-07100)

12. REMOVE COMPANION FLANGE

(a) Using a chisel and hammer, unstake the nut.

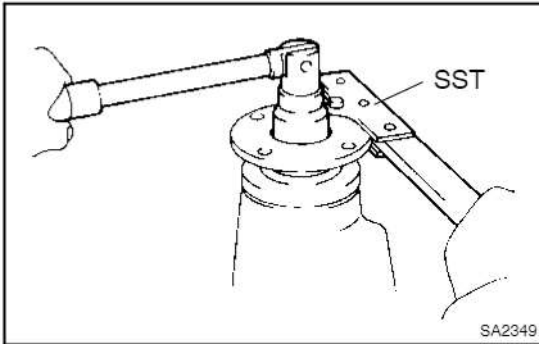

- (b) Using SST to hold the flange, remove the nut.
SST 09330-00021

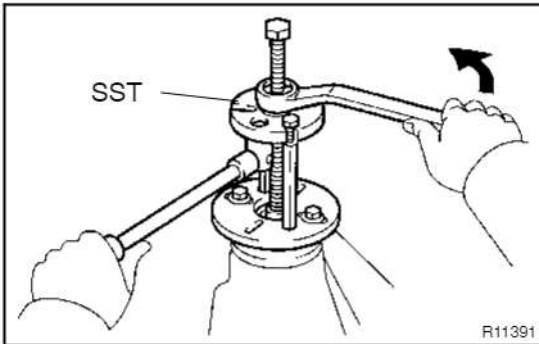

- (c) Using SST, remove the companion flange.
SST 09950-30011 (09951-03010, 09953-03010,
09954-03010, 09955-03030, 09956-03020)

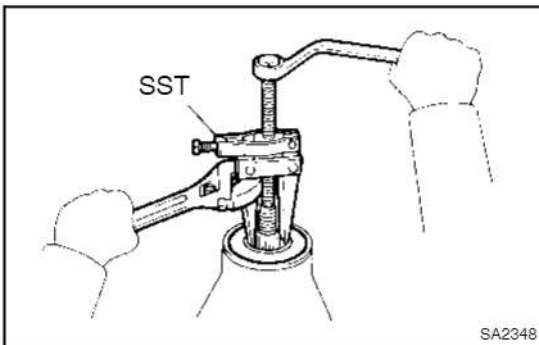

13. REMOVE OIL SEAL AND OIL SLINGER

- (a) Using SST, remove the oil seal from the differential carrier.
SST 09308-10010
(b) Remove the oil slinger.

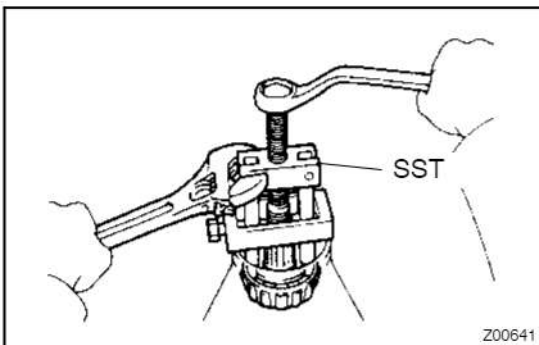

14. REMOVE REAR BEARING

- Using SST, remove the rear bearing from the drive pinion.
SST 09556-22010
If the rear bearing is damaged or worn, replace the rear bearing.

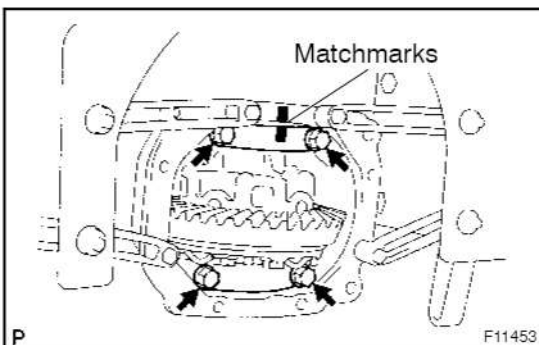

15. REMOVE DIFFERENTIAL CASE ASSEMBLY

- (a) Place matchmarks on the bearing cap and differential carrier.
(b) Remove the 4 bolts and 2 bearing caps.

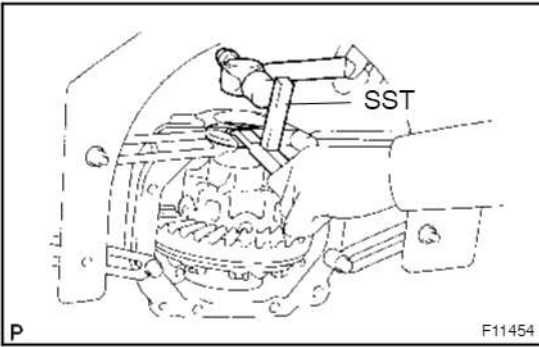

- (c) Using SST and a hammer, remove the 2 side bearing plate washers.

SST 09504-22011

HINT:

Measure the plate washer and note down the thickness.

- (d) Remove the differential case with the bearing outer races from the differential carrier.

HINT:

Tag the bearing outer races to show the location for reassembling.

16. REMOVE DRIVE PINION AND BEARING SPACER FROM DIFFERENTIAL CARRIER

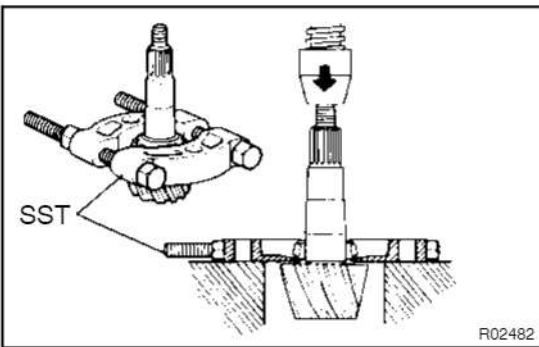

17. REMOVE DRIVE PINION FRONT BEARING

- (a) Using SST and a press, remove the front bearing from the drive pinion.

SST 09950-00020

HINT:

If the drive pinion or ring gear is damaged, replace them as a set.

- (b) Remove the washer.

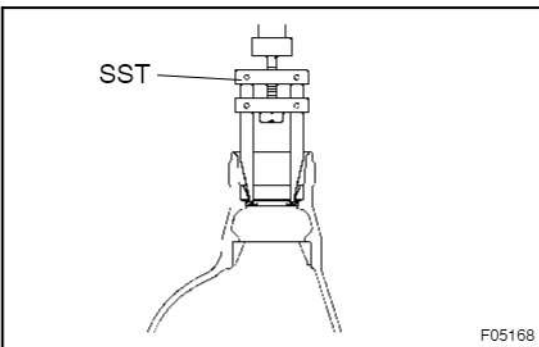

18. REMOVE DRIVE PINION FRONT AND REAR BEARING OUTER RACES AND OIL STORAGE RING

- (a) Using SST, remove the rear bearing outer race.

SST 09308-00010

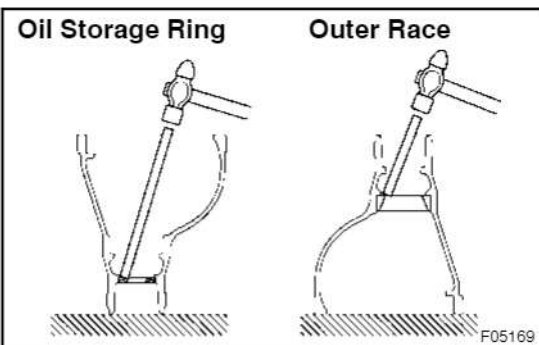

- (b) Using a brass bar and hammer, remove the oil storage ring and front bearing outer race.

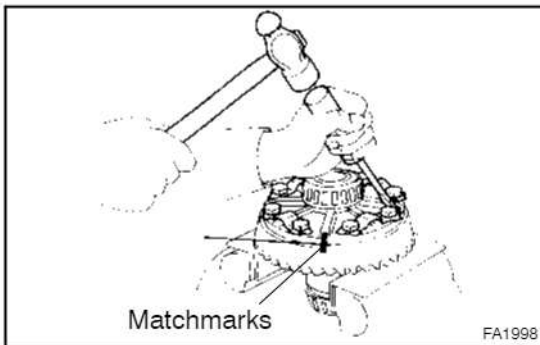
**19. REMOVE RING GEAR**

- Place matchmarks on the ring gear and differential case.
- Using a screwdriver and hammer, unstick the 5 lock plates.
- Remove the 10 bolts and 5 lock plates.
- Using a plastic hammer, tap on the ring gear to separate it from the differential case.

20. CHECK DIFFERENTIAL CASE RUNOUT

- Place the bearing outer races on their respective bearings. Check that the left and right outer races are not interchanged.
- Install the assembled plate washers onto the side bearing.
- Install the differential case in the differential carrier.

HINT:

If it is difficult to install the differential case into the carrier, replace the plate washer with a thinner one.

However, select a plate washer that allows no clearance between it and the carrier.

- Align matchmarks on the bearing cap and differential carrier.
- Install and uniformly tighten the 4 bolts a little at a time.

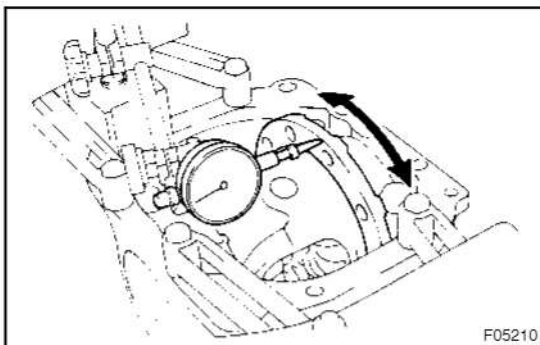

- Using a dial indicator, measure the differential case runout.

Maximum case runout: 0.07 mm (0.0028 in.)

If the runout is greater than the maximum, replace the differential case and side bearings as a set.

- Remove the differential case.

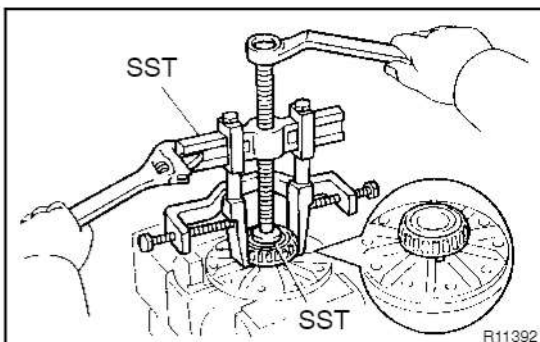
**21. REMOVE SIDE BEARINGS**

Using SST, remove the 2 side bearings from the differential case.

SST 09950-40011 (09951-04020, 09952-04010, 09953-04030, 09954-04010, 09955-04061, 09957-04010, 09958-04011), 09950-60010 (09951-00480)

HINT:

Fix the claws of SST to the notches in the differential case.

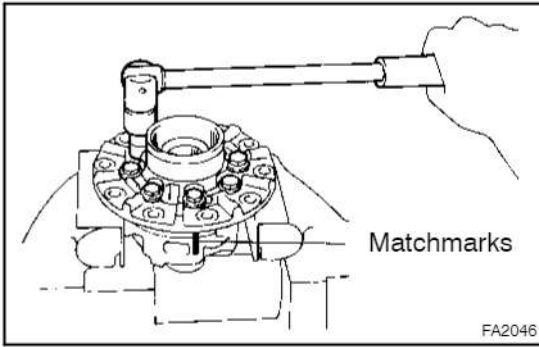

22. DISASSEMBLE DIFFERENTIAL CASE

- (a) Place matchmarks on the LH and RH cases.
- (b) Remove the 8 bolts uniformly, a little at a time.
- (c) Using a plastic hammer, separate the LH and RH cases.
- (d) Remove the spider, 2 side gears, side gear thrust washers, 4 pinion gears and pinion gear thrust washers from the RH differential case.

REASSEMBLY

HINT:

- Using a shop rag, clean off any foreign object from the parts.
- Apply all of the sliding and rotating surfaces with hypoid gear oil.

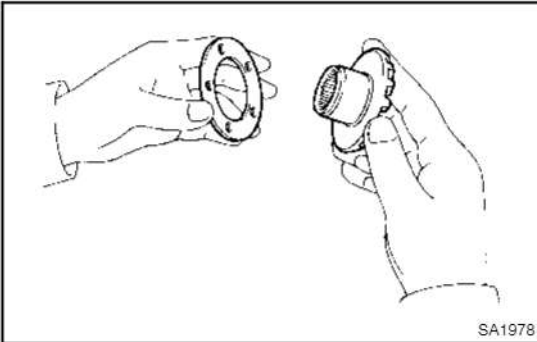

1. MEASURE SIDE GEAR BACKLASH AND ASSEMBLE DIFFERENTIAL CASE

- Install the 2 side gear thrust washers to the side gears.
- Install the 2 side gears to the RH case.
- Install the 4 pinion gears and pinion gear thrust washers to the spider.
- Install the pinion gears with the spider to the RH case.

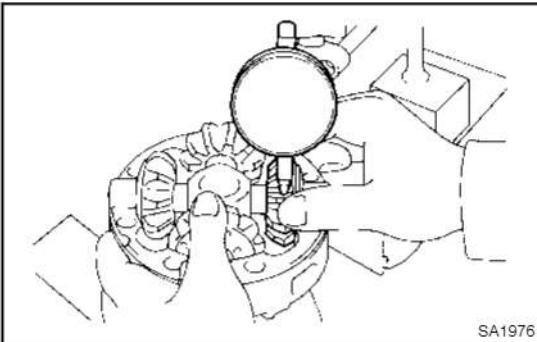

- Using a dial indicator, holding the side gear and spider, measure the side gear backlash,

Backlash: 0.05 – 0.20 mm (0.0020 – 0.0079 in.)

HINT:

- Measure at all 4 locations.
 - Measure the backlash at the RH case and at the LH case.
- If the backlash is not within the specification, install a thrust washer of a different thickness.

Thrust washer thickness

Thickness mm (in.)	Thickness mm (in.)
0.9 (0.035)	1.2 (0.047)
1.0 (0.039)	1.3 (0.051)
1.1 (0.043)	-

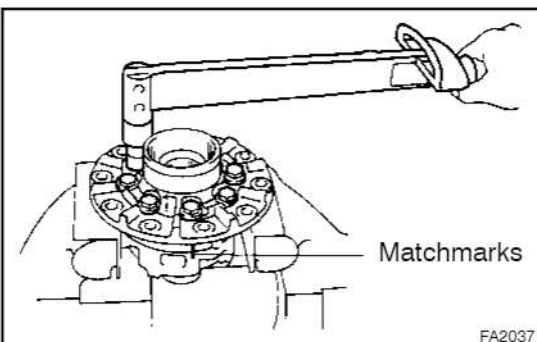

- Align the matchmarks on the LH and RH cases.
- Torque the 8 bolts uniformly a little at a time.

Torque: 47 N·m (480 kgf·cm, 35 ft·lbf)

2. INSTALL RING GEAR ON DIFFERENTIAL CASE

- (a) Clean the contact surfaces of the differential case and ring gear.

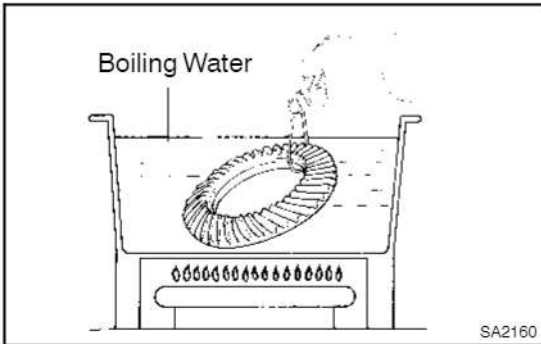

- (b) Heat the ring gear to approx. 100°C (212°F) in boiling water.
- (c) Carefully take the ring gear out of the boiling water.
- (d) After the moisture on the ring gear has completely evaporated, quickly install the ring gear to the differential case.

HINT:

Align the matchmarks on the ring gear and differential case.

- (e) Temporarily install 5 new lock plates and 10 bolts so that the bolt holes in the ring gear and differential case are not misaligned.
- (f) After the ring gear has cooled sufficiently, torque the 10 ring gear set bolts.

Torque: 97 N·m (985 kgf·cm, 71 ft·lbf)

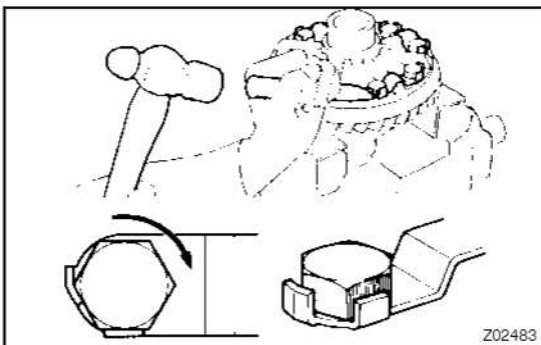

- (g) Using a chisel and hammer, stake the 5 lock plates.

HINT:

Stake the claws of the lock plates to fix the bolts. For the claw contacting the protruding portion of the bolt, stake only the half of it along the tightening direction.

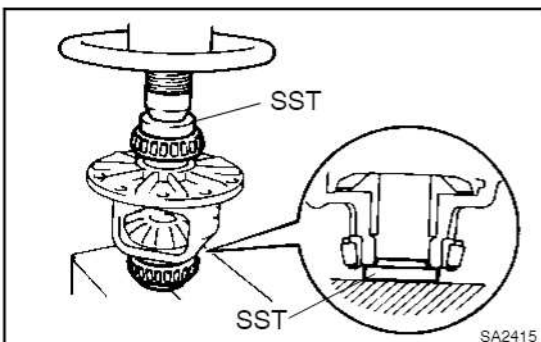

3. INSTALL SIDE BEARINGS

Using SST and a press, install the 2 side bearings to the differential case.

SST 09223-15020, 09950-60010 (09951-00480)

4. CHECK RING GEAR RUNOUT

- (a) Place the bearing outer races on their respective bearings. Check that the left and right outer races are not interchanged.
- (b) Install the assembled plate washers onto the side bearing.
- (c) Install the differential case in the differential carrier.

HINT:

If it is difficult to install the differential case into the carrier, replace the plate washer with a thinner one.

However, select a plate washer that allows no clearance between it and the carrier.

- (d) Align matchmarks on the bearing cap and differential carrier.
- (e) Install and uniformly tighten the 4 bolts a little at a time.

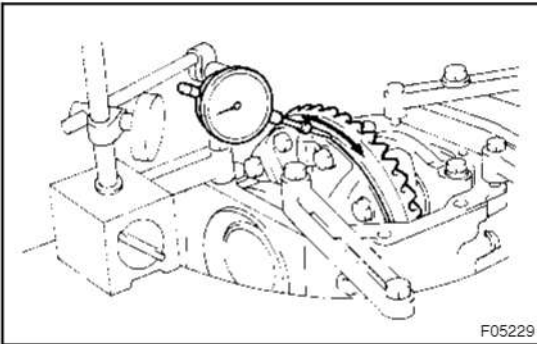

F05229

- (f) Using a dial indicator, measure the ring gear runout.

Maximum runout: 0.07 mm (0.0028 in.)

- (g) Remove the differential carrier.

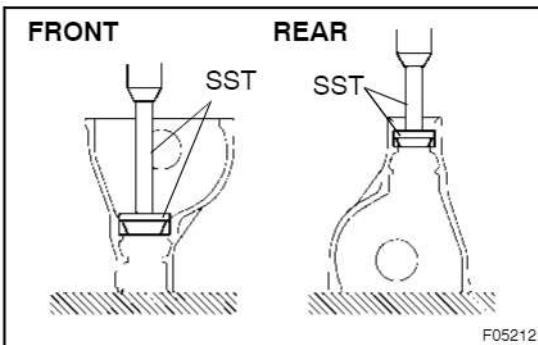

F05212

5. INSTALL DRIVE PINION FRONT AND REAR BEARING OUTER RACES

- (a) Using SST and a press, install the front bearing outer race.

SST 09950-60020 (09951-00780), 09950-70010 (09951-07150)

- (b) Using SST and a press, install the rear bearing outer race.

SST 09950-60020 (09951-00710), 09950-70010 (09951-07150)

6. INSTALL DRIVE PINION FRONT BEARING

- (a) Install the washer on the drive pinion.

HINT:

First fit a washer with the same thickness as the washer which was removed, then after checking the tooth contact pattern, replace the washer with one of a different thickness if necessary.

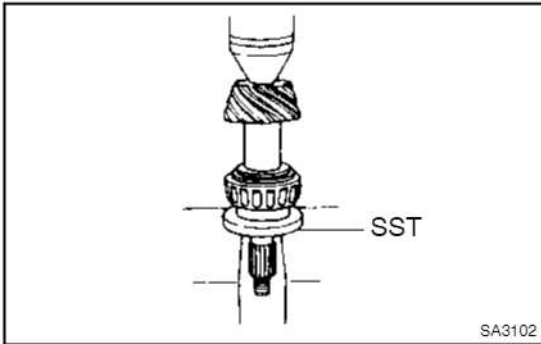

- (b) Using SST and a press, install the front bearing onto the drive pinion.

SST 09506-30012

7. TEMPORARILY ADJUST DRIVE PINION PRELOAD

- (a) Install the drive pinion and rear bearing.

HINT:

Assemble the spacer and oil seal after adjusting the gear contact pattern.

- (b) Install the oil slinger.

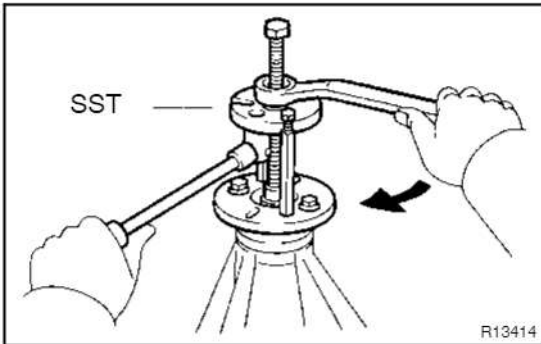

- (c) Using SST, install the companion flange.

SST 09950-30010, (09951-03010, 09953-03010, 09954-03010, 09955-03030, 09956-03020)

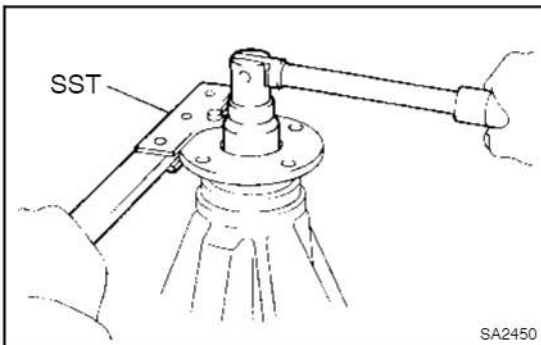

- (d) Using SST to hold the flange and adjust the drive pinion preload by tightening the nut.

NOTICE:

- Coat the nut and threads of the drive pinion with gear oil.
- As there is no spacer, tighten the nut a little at a time, being careful not to overtighten.

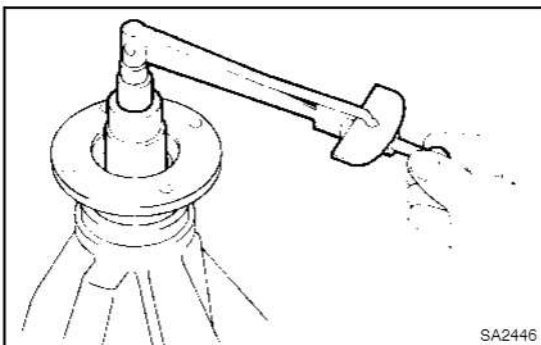

- (e) Using a torque wrench, measure the preload.

Preload (at starting):

New bearing

1.0 - 1.6 N·m (10 - 16 kgf·cm, 8.7 - 13.9 in.·lbf)

Reused bearing

0.5 - 0.8 N·m (5 - 8 kgf·cm, 4.3 - 6.9 in.·lbf)

HINT:

Measure the total preload after turning the bearing clockwise and counterclockwise several times to make the bearing smooth.

8. INSTALL DIFFERENTIAL CASE IN DIFFERENTIAL CARRIER

- (a) Place the bearing outer races on their respective bearings. Check that the left and right outer races are not interchanged.

- (b) Install the differential case in the differential carrier.

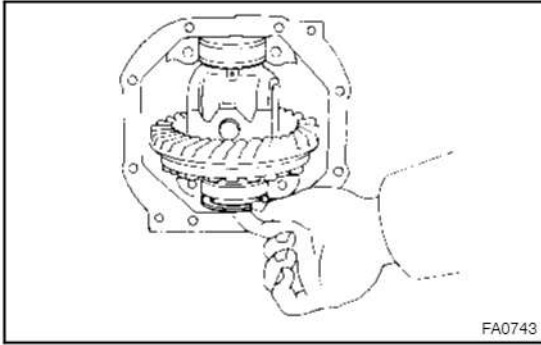

9. ADJUST RING GEAR BACKLASH

- (a) Install the plate washer on the ring gear back side.

HINT:

Make sure that the ring gear has backlash.

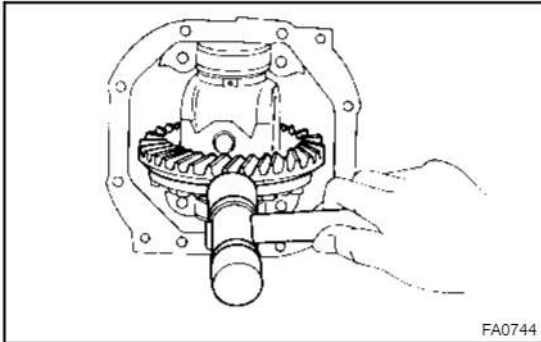

- (b) Tap on the ring gear with a plastic hammer so that the washer fits to the bearing.

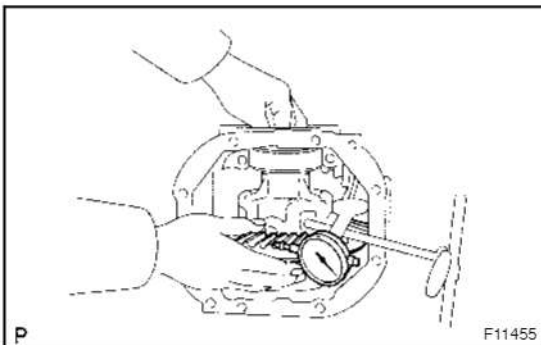

- (c) Using a dial indicator, measure the side gear backlash while holding one pinion gear toward the differential case.

Backlash (Reference): 0.13 mm (0.0051 in.)

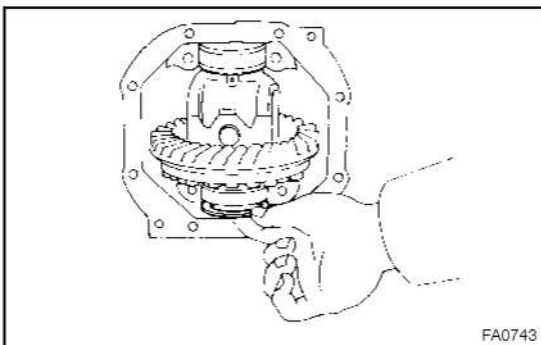

- (d) Select a plate washer for back side ring gear, using the backlash as reference.

Side plate washer thickness

Thickness mm (in.)	Thickness mm (in.)
2.58 (0.1016)	3.04 (0.1197)
2.60 (0.1024)	3.06 (0.1205)
2.62 (0.1031)	3.08 (0.1213)
2.64 (0.1039)	3.10 (0.1220)
2.66 (0.1047)	3.12 (0.1228)
2.68 (0.1055)	3.14 (0.1236)
2.70 (0.1063)	3.16 (0.1244)
2.72 (0.1071)	3.18 (0.1252)
2.74 (0.1079)	3.20 (0.1260)
2.76 (0.1087)	3.22 (0.1268)
2.78 (0.1094)	3.24 (0.1276)
2.80 (0.1102)	3.26 (0.1283)
2.82 (0.1110)	3.28 (0.1291)
2.84 (0.1118)	3.30 (0.1299)
2.86 (0.1126)	3.32 (0.1307)
2.88 (0.1134)	3.34 (0.1315)
2.90 (0.1142)	3.36 (0.1323)
2.92 (0.1150)	3.38 (0.1331)
2.94 (0.1157)	3.40 (0.1339)
2.96 (0.1165)	3.42 (0.1346)
2.98 (0.1173)	3.44 (0.1354)
3.00 (0.1181)	3.46 (0.1362)
3.02 (0.1189)	3.48 (0.1370)

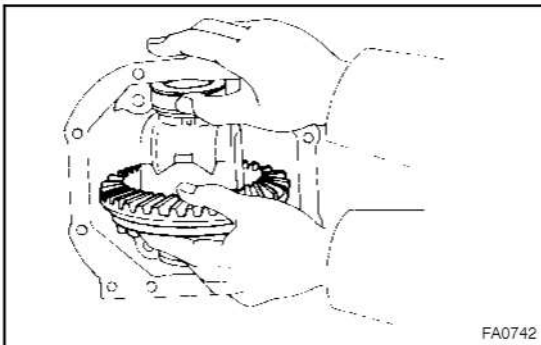

- (e) Select a ring gear teeth side plate washer so that is no clearance between the outer race and case.

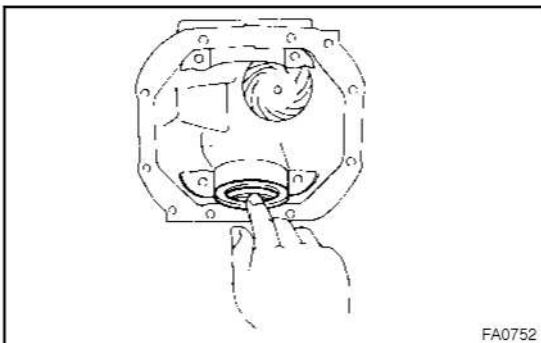

- (f) Remove the plate washers and differential case.
- (g) Install the plate washer into the ring gear back side of the carrier.

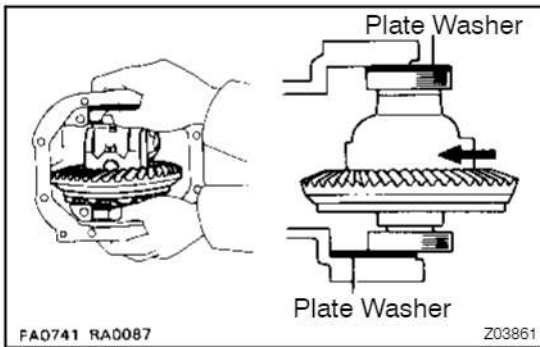

- (h) Place the other plate washer onto the differential case together with the outer race, and install the differential case with the outer race into the carrier.
- (i) Tap on the ring gear with a plastic hammer so that the washers fit to the bearing.

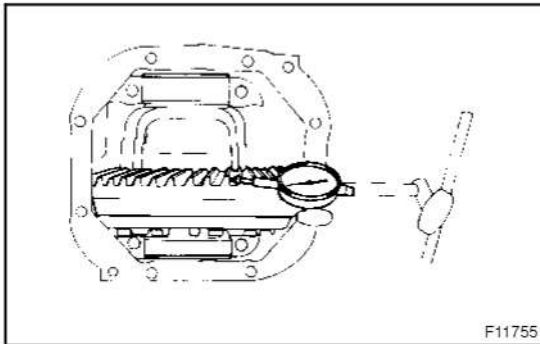

- (j) Using a dial indicator, measure the ring gear backlash.
Backlash: 0.13 – 0.18 mm (0.0051 – 0.0070 in.)
If the backlash is not within the specification, adjust by either increasing or decreasing the thickness of washers on both sides by an equal amount.

HINT:

There should be no clearance between the plate washer and case.

Make sure that there is ring gear backlash.

10. ADJUST SIDE BEARING PRELOAD

- (a) Remove the ring gear teeth side plate washer and measure the thickness.

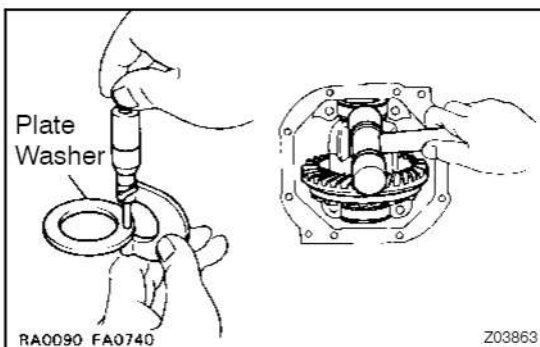

- (b) Using the backlash as a reference, install a new washer of 0.06 – 0.09 mm (0.0024 – 0.0035 in.) thicker than the washer removed.

HINT:

Select a washer which can be pressed in 2/3 of the way with your finger.

- (c) Using a plastic hammer, install the plate washer.
- (d) Align matchmarks on the bearing cap and differential carrier.
- (e) Tighten the 4 bolts.

Torque: 85 N·m (870 kgf·cm, 63 ft·lbf)

HINT:

Turn the ring gear several times to make the side bearings smooth.

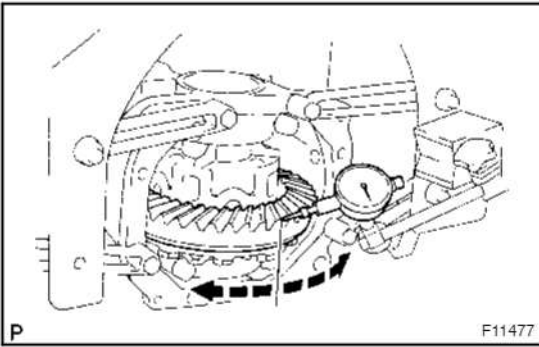

- (f) Using a dial indicator, adjust the ring gear backlash until it is within the specification.

Backlash: 0.13 – 0.18 mm (0.0051 – 0.0070 in.)

If the backlash is not within the specification, adjust by either increasing or decreasing the thickness of washers on both sides by an equal amount.

HINT:

The backlash will change by about 0.02 mm (0.0008 in.) corresponding to 0.03 mm (0.0012 in.) change in the plate washer.

11. MEASURE TOTAL PRELOAD

Using a torque wrench, measure the total preload.

Total preload (at starting):

Drive pinion preload plus

0.4 – 0.6 N·m (4 – 6 kgf·cm, 3.5 – 5.2 in.·lbf)

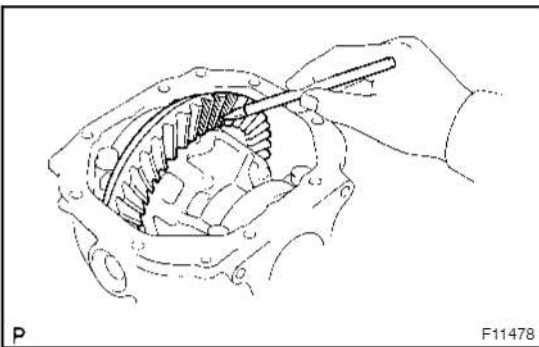

12. INSPECT TOOTH CONTACT BETWEEN RING GEAR AND DRIVE PINION

- Coat 3 or 4 teeth at 3 different positions on the ring gear with red lead primer.
- Hold the companion flange firmly and rotate the ring gear in both directions.
- Inspect the tooth contact pattern.

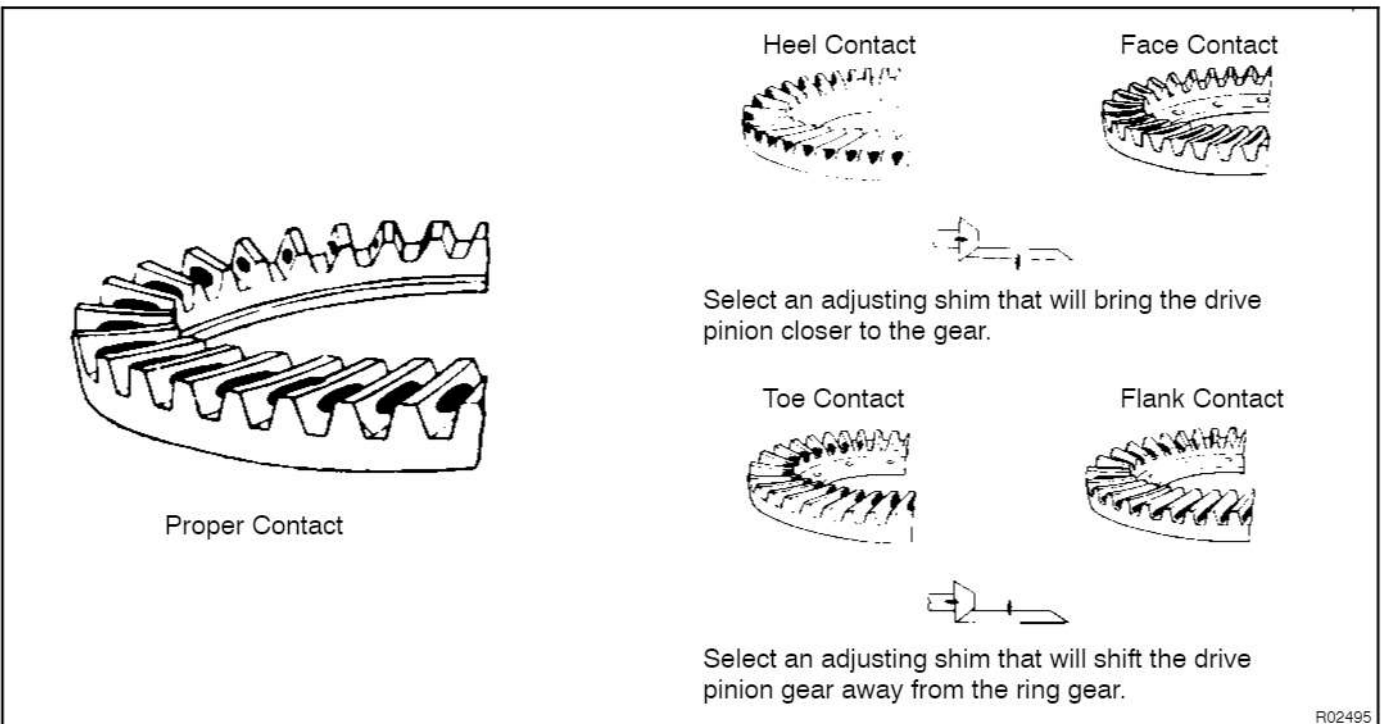

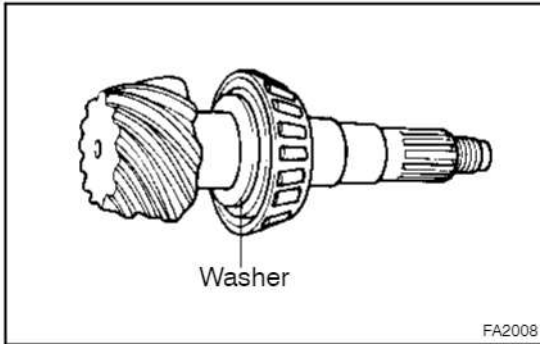

If the teeth are not contacting properly, use the following table to select a proper washer for correction.

Washer thickness

Thickness mm (in.)	Thickness mm (in.)
1.70 (0.0669)	2.03 (0.0799)
1.73 (0.0681)	2.06 (0.0811)
1.76 (0.0693)	2.09 (0.0822)
1.79 (0.0704)	2.12 (0.0835)
1.82 (0.0717)	2.15 (0.0847)
1.85 (0.0729)	2.18 (0.0858)
1.88 (0.0740)	2.21 (0.0870)
1.91 (0.0752)	2.24 (0.0882)
1.94 (0.0764)	2.27 (0.0894)
1.97 (0.0776)	2.30 (0.0906)
2.00 (0.0787)	2.33 (0.0918)

13. REMOVE COMPANION FLANGE (See page SA-2)
14. REMOVE OIL SLINGER
15. REMOVE REAR BEARING (See page SA-2)
16. REMOVE REAR BEARING OUTER RACE (See page SA-2)

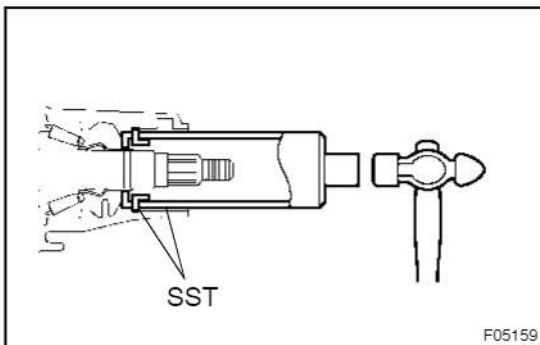

17. INSTALL BEARING SPACER AND OIL STORAGE RING

- (a) Install a new bearing spacer.
- (b) Using SST and a hammer, install a new oil storage ring.
SST 09316-60011 (09316-00011), 09506-35010

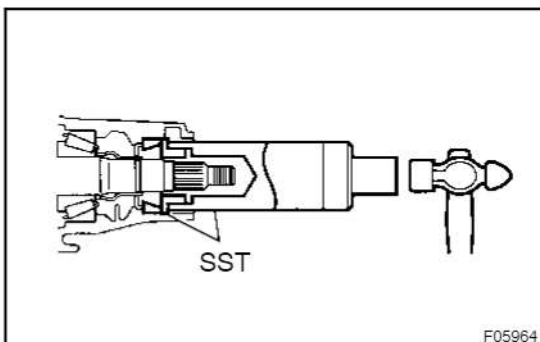

18. INSTALL REAR BEARING OUTER RACE

Using SST and a hammer, install the bearing outer race.

SST 09316-60011 (09316-00011), 09506-35010

19. INSTALL REAR BEARING AND OIL SLINGER

20. INSTALL OIL SEAL

- (a) Coat the hypoid gear oil to a new oil seal periphery.

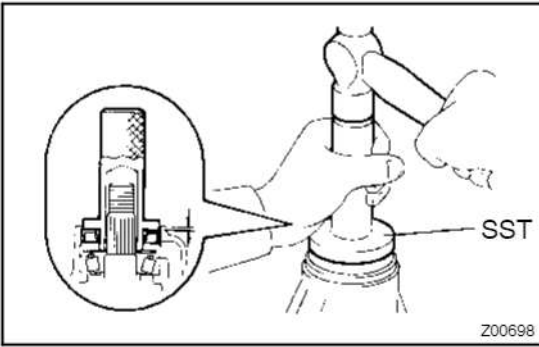

- (b) Using SST and a hammer, install a new oil seal.
SST 09554-30011
Oil seal drive in depth: 1.5 mm (0.059 in.)
- (c) Coat MP grease to the oil seal lip.

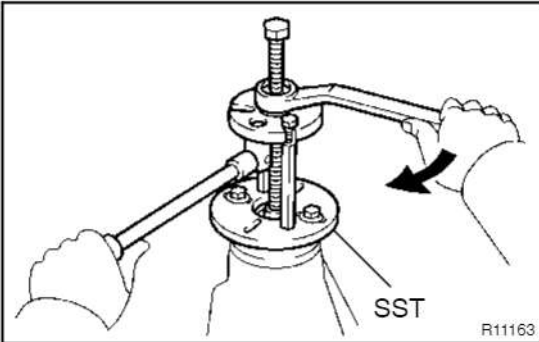

21. INSTALL COMPANION FLANGE

- (a) Using SST, install the companion flange.
SST 09950-30010 (09951-03010, 09953-03010, 09954-03010, 09955-03030, 09956-03020)
- (b) Coat the thread of a new nut with hypoid gear oil LSD.

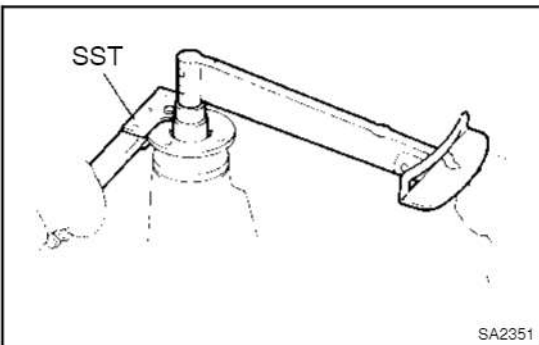

- (c) Using SST to hold the flange, tighten the nut.
SST 09330-00021
Torque: 108 N·m (1,100 kgf·cm, 80 ft·lbf)

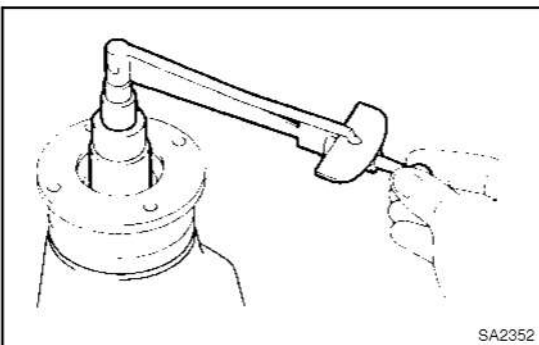

22. ADJUST DRIVE PINION PRELOAD

Using a torque wrench, measure the drive pinion preload using the backlash of the drive pinion and ring gear.

Preload (at starting):

New bearing

1.0 - 1.6 N·m (10 - 16 kgf·cm, 8.7 - 13.9 in·lbf)

Reused bearing

0.5 - 0.8 N·m (5 - 8 kgf·cm, 4.3 - 6.9 in·lbf)

If the preload is greater than the specification, replace the bearing spacer.

If the preload is less than the specification, retighten the nut a force of 13 N·m (130 kgf·cm, 9 ft·lbf) at a time until the specified preload is reached.

SST 09330-00021

Torque: 338 N·m (3,447 kgf·cm, 249 ft·lbf) or less

If the maximum torque is exceeded while retightening the nut, replace the bearing spacer and repeat the preload procedure. Do not loosen the pinion nut to reduce the preload.

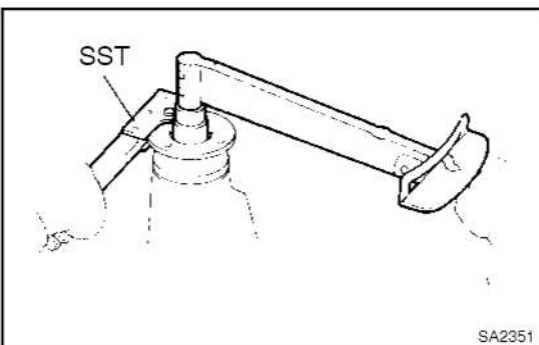

23. RECHECK TOTAL PRELOAD (See page SA-2)
24. RECHECK RING GEAR BACKLASH (See page SA-2)
25. RECHECK TOOTH CONTACT BETWEEN RING GEAR AND DRIVE PINION (See page SA-8)
26. CHECK RUNOUT OF COMPANION FLANGE (See page SA-2)
27. STAKE DRIVE PINION NUT

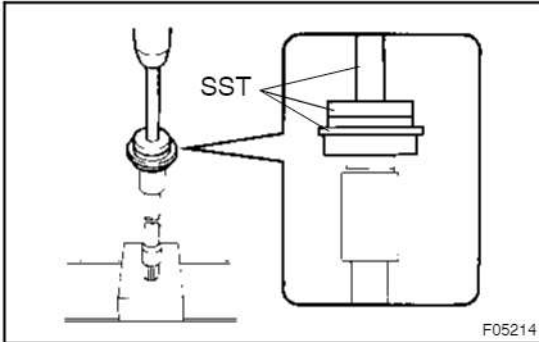

28. INSTALL SIDE GEAR BEARING

Using SST and a press, install the bearing to side gear shaft.
SST 09502-12010, 09950-60020 (09951-00730),
09950-70010 (09951-07100)

29. INSTALL DIFFERENTIAL TUBE ASSEMBLY

- (a) Clean surfaces with FIPG material attached to using gasoline or alcohol.
- (b) Apply FIPG to the differential tube.

FIPG:

Part No. 08826 - 00090, THREE BOND 1281 or equivalent.

HINT:

Install the differential tube within 10 minutes after applying FIPG.

- (c) Install the differential tube with 4 bolts to the differential tube.
Torque: 105 N·m (1,070 kgf·cm, 77 ft·lbf)
- (d) Install the side gear shaft.
- (e) Using a snap ring expander, install the snap ring.

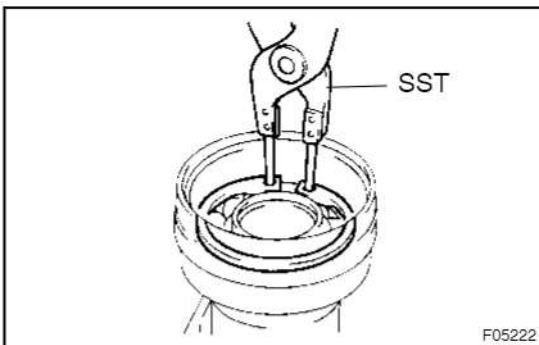

- (f) Using SST, install the snap ring.
SST 09350-30020 (09350-07060)

30. INSTALL SIDE GEAR SHAFT OIL SEALS

- (a) Coat the hypoid gear oil to a new oil seal periphery.

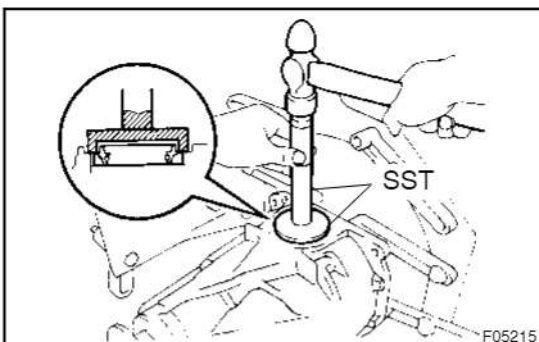

- (b) Using SST and a hammer, install 2 new oil seals.
SST 09550-00032, 09950-70010 (09951-07150)
- (c) Coat MP grease to the oil seal lip.

31. REMOVE DIFFERENTIAL CARRIER FROM OVERHAUL STAND, ETC.

32. INSTALL DIFFERENTIAL CARRIER COVER

- (a) Install the oil deflector with 2 bolts to the carrier cover.
Torque: 7.3 N·m (74 kgf·cm, 64 in·lbf)
- (b) Install the breather plug to the carrier cover.
- (c) Remove any old FIPG material and be careful not to drop oil on the contact surfaces of the differential carrier and carrier cover.
- (d) Clean surfaces with FIPG with material attached to using gasoline or alcohol.

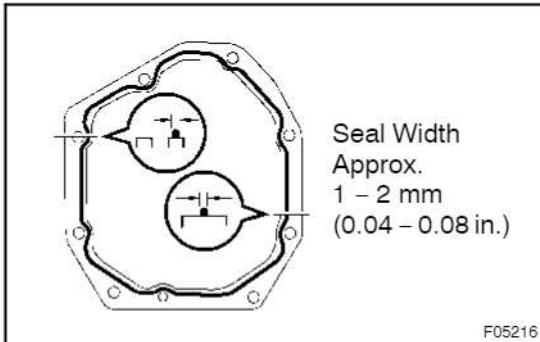

- (e) Apply FIPG to the carrier cover, as shown.

FIPG:

**Part No. 08826-00090, THREE BOND 1281
or equivalent.**

HINT:

Install the carrier cover within 10 minutes after applying FIPG.

- (f) Install the differential carrier cover with the 9 bolts.

Torque: 47 N·m (475 kgf·cm, 34 ft·lbf)

BRAKE FLUID (w/ ABS) BLEEDING

BR12E-03

HINT:

- If any work is done on the brake system or if air in the brake lines is suspected, bleed the air from the system.
- When bleeding, keep the amount of the fluid within the line of reservoir between Min. and Max.

NOTICE:

- **Do not let brake fluid remain on painted surfaces. Wash it off immediately.**
 - **With the reservoir cap removed, when depressing the brake pedal, the fluid will spray.**
1. **FILL RESERVOIR WITH BRAKE FLUID**
Fluid: SAE J1703 or FMVSS NO. 116 DOT3
 2. **In case of using hand-held tester:**
BLEED HYDRAULIC BRAKE BOOSTER

HINT:

If the hydraulic brake booster has been disassembled, disconnect the brake line from the hydraulic brake booster or if the reservoir becomes empty, bleed the hydraulic brake booster.

- (a) Turn the ignition switch OFF, depress the brake pedal more than 40 times.

HINT:

When a pressure in power supply system is released, reaction force becomes light and stroke becomes longer.

- (b) Turn the ignition switch ON, check that the pump stops after approx. 30 to 40 sec.

NOTICE:

When the pump does not stop, repeat step (a) and (b) again.

- (c) With the ignition switch remained ON, depress the brake pedal more than 20 times.
- (d) Observe the procedure in step 4 and bleed the right and left front brake caliper.
- (e) Holding the brake pedal depressed, bleed the right and left rear brake caliper.

HINT:

It is not necessary to depress the pedal continuously, as brake fluid flows out by first depressing.



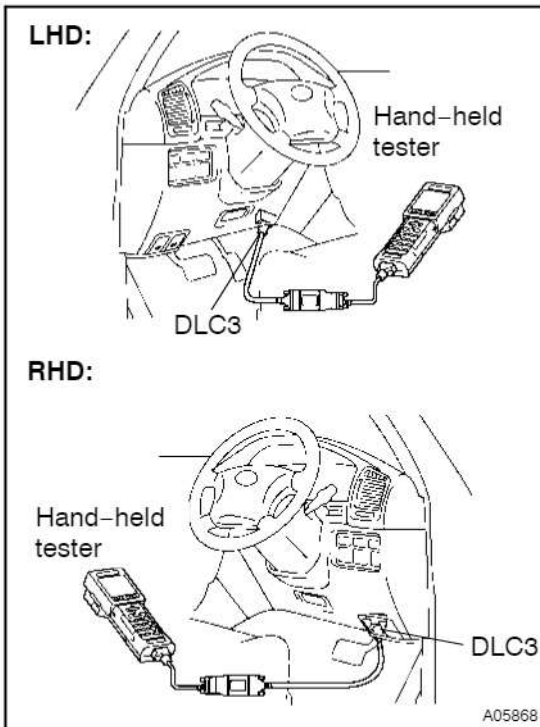

- (f) Connect hand-held tester.
- (1) Turn the ignition switch OFF, connect the hand-held tester to DLC3.
 - (2) Turn the ignition switch ON and select "AIR BLEEDING" on the hand-held tester.

HINT:

Please refer to the hand-held tester operator's manual for further details.

- (g) Bleed right front brake line.
- (1) Select "FR LINE" on the hand-held tester.
 - (2) With "FR LINE" turned ON with the hand-held tester, depress the brake pedal and hold it to bleed the right front brake caliper.
 - (3) Repeat step (2) until there are no more air bubbles in the fluid.
- (h) Bleed left front brake line.
- (1) Select "FL LINE" on the hand-held tester.
 - (2) With "FL LINE" turned ON with the hand-held tester, depress the brake pedal and hold it to bleed the left front brake caliper.
 - (3) Repeat step (2) until there are no more air bubbles in the fluid.
- (i) w/ ABS & TRC & VSC only:
Bleed rear brake line.
- (1) Select "RR LINE" on the hand-held tester.
 - (2) With "RR LINE" turned ON with the hand-held tester, bleed the left and right rear brake caliper.
- (j) Disconnect the hand-held tester from DLC3.
- (k) Clear the DTC ([See page DI-4](#)).

**3. In case of using ABS actuator checker (SST):
BLEED HYDRAULIC BRAKE BOOSTER**

HINT:

If the hydraulic brake booster has been disassembled, disconnect the brake line from the hydraulic brake booster or if the reservoir becomes empty, bleed the hydraulic brake booster.

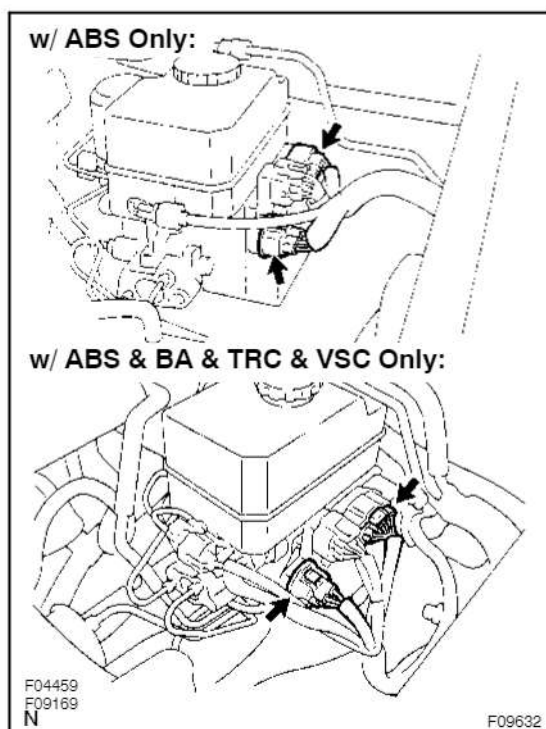

- (a) Disconnect the 2 connectors from the hydraulic brake booster.

- (b) Connect the actuator checker (SST) to the hydraulic brake booster side wire harness via the sub-wire harness (SST), as shown in the chart below.
SST 09990-00150, 09990-00480

HINT:

Connect the connector with the label of "AIR BLEED" attached to the connector of actuator checker.

- (c) Connect the red cable of the checker to the battery positive (+) terminal and the black cable to the negative (-) terminal.

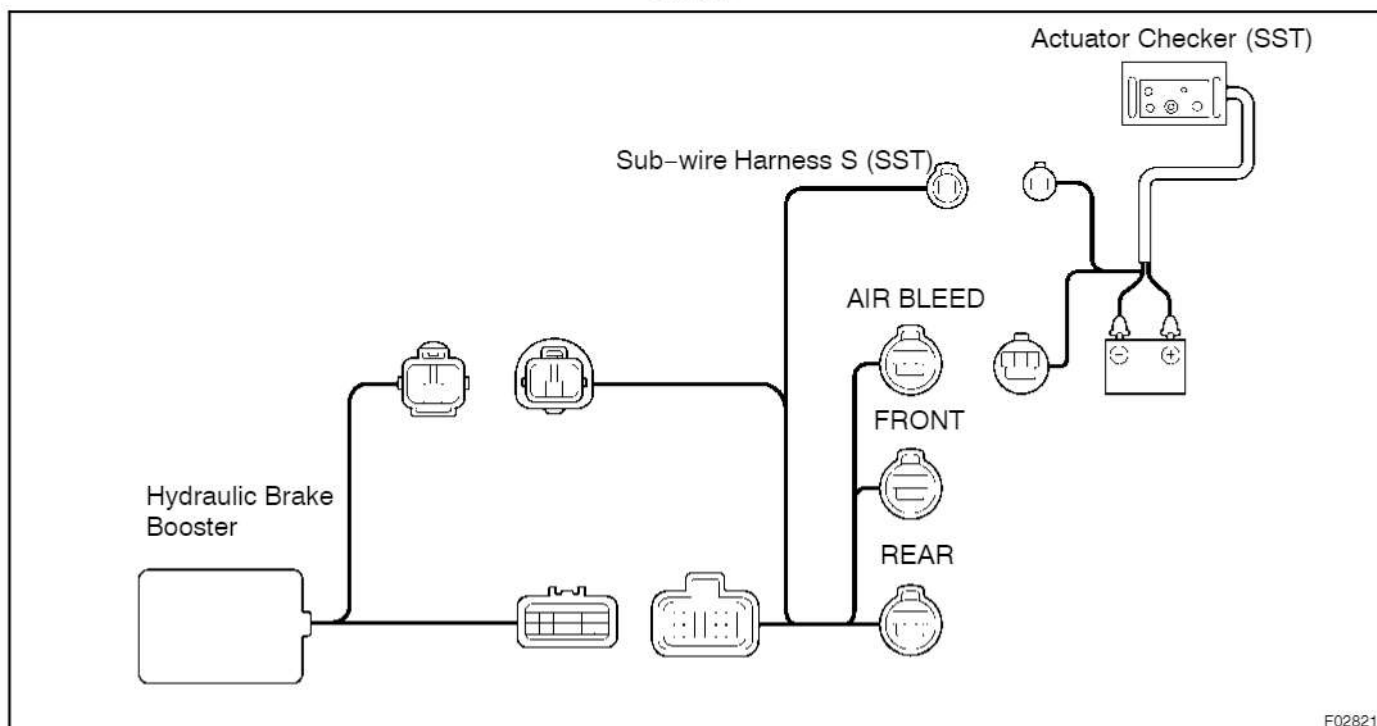

- (d) Turn the ignition switch OFF, depress the brake pedal more than 40 times.

HINT:

When a pressure in power supply system is released, reaction force becomes light and stroke becomes longer.

- (e) Turn the ignition switch ON, check that the pump stops after 30 to 40 sec.

NOTICE:

When the pump does not stop, repeat step (d) and (e) again.

- (f) With the ignition switch remained ON, depress the brake pedal more than 20 times.
- (g) Observe the procedure in step 4 and bleed the right and left front wheel caliper.
- (h) Holding the brake pedal depressed, bleed the right and left rear brake caliper.

HINT:

It is not necessary to depress the pedal continuously, as brake fluid flows out by first depressing.

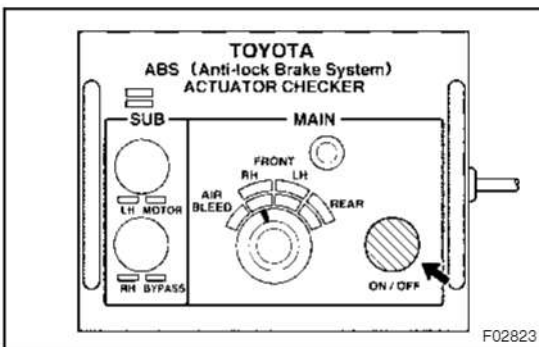

- (i) Bleed right front brake line.
- (1) Turn the selector switch of the actuator checker to the "FRONT RH" position.
 - (2) Push and hold in MAIN push switch, depress the brake pedal and hold it to bleed the right front brake caliper.

NOTICE:

Do not keep the MAIN switch pushed in for more than 10 sec. When operating it continuously, set the interval of more than 20 sec.

- (3) Repeat step (2) until there are no more air bubbles in the fluid.

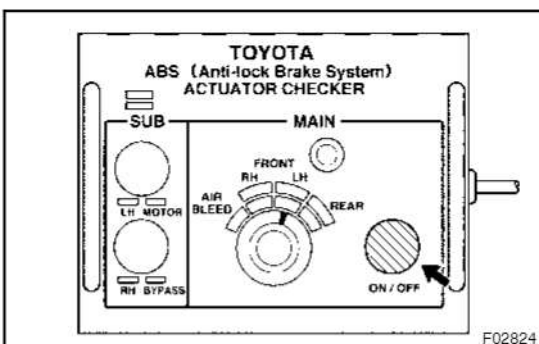

- (j) Bleed left front brake line.
- (1) Turn the selector switch of the actuator checker to the "FRONT LH" position.
 - (2) Push and hold in the MAIN push switch, depress the brake pedal and hold it to bleed the left front brake caliper.

NOTICE:

Do not keep the MAIN switch pushed in for more than 10 sec. When operating it continuously, set the interval of more than 20 sec.

- (3) Repeat step (2) until there are no more air bubbles in the fluid.

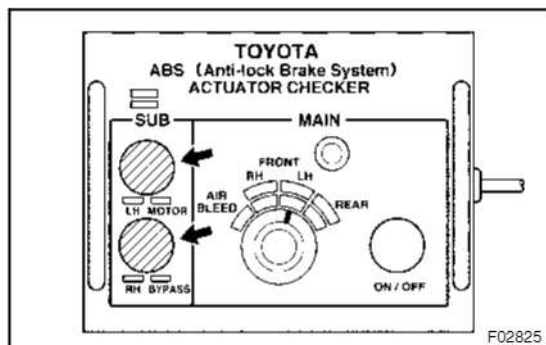

- (k) w/ ABS & TRC & VSC only:
Bleed right rear brake line.
- (1) Push and hold in the "SUB LH" and "SUB RH" switches, bleed the right rear brake caliper.

NOTICE:

Do not keep the MAIN switch pushed in for more than 10 sec. When operating it continuously, set the interval of more than 20 sec.

- (2) Repeat step (1) until there are no more air bubbles in the fluid.
- (l) Observe the procedure in step (k) and bleed left rear brake line.
- (m) Disconnect the actuator checker (SST) and sub-wire harness (SST) from the actuator.
SST 09990-00150, 09990-00480
- (n) Connect the 2 connectors to the hydraulic brake booster.
- (o) Clear the DTC (See page DI-4).

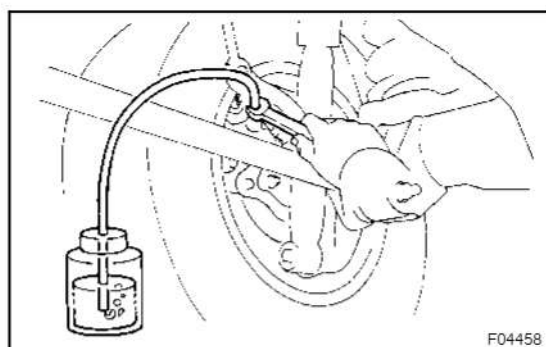
**4. BLEED BRAKE LINE**

- (a) Connect the vinyl tube to the brake caliper.
- (b) Depress the brake pedal several times, then loosen the bleeder plug with the pedal held down.
- (c) At the point when fluid stops coming out, tighten the bleeder plug, then release the brake pedal.
- (d) Repeat (b) and (c) until all the air in the fluid has been bled out.
- (e) Repeat the above procedure to bleed the brake line for each wheel.

Torque: 11 N·m (110 kgf·cm, 8 ft·lbf)

5. CHECK FLUID LEVEL IN RESERVOIR

- (a) With the ignition switch OFF, depress the brake pedal more than 40 times.

HINT:

When a pressure in power supply system is released, reaction force becomes light and stroke becomes longer.

- (b) Remove the reservoir cap. Add brake fluid up to the "MAX" line.

Fluid: SAE J1703 or FMVSS NO. 116 DOT3

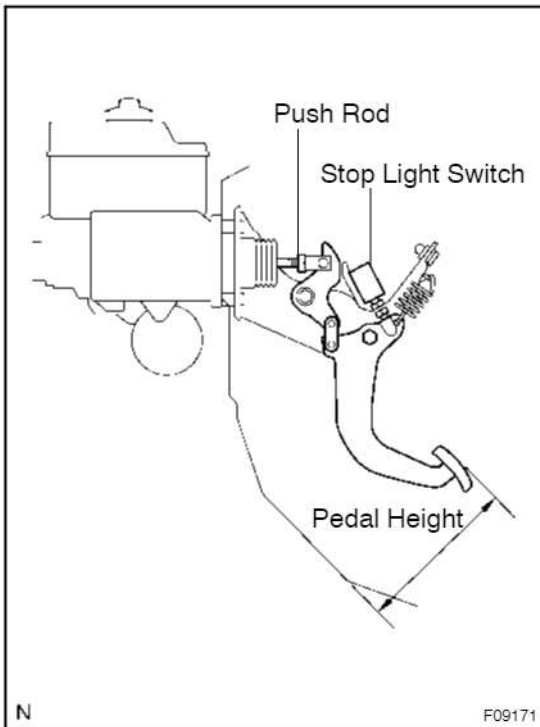

BRAKE PEDAL (w/ ABS) ON-VEHICLE INSPECTION

BR0J8-10

1. CHECK PEDAL HEIGHT

Pedal height from asphalt sheet:

LHD: 183.7 – 193.7 mm (7.232 – 7.626 in.)

RHD: 190.2 – 200.2 mm (7.488 – 7.882 in.)

If the pedal height is incorrect, adjust it.

2. IF NECESSARY, ADJUST PEDAL HEIGHT

- (a) Remove the scuff plate, cowl side trim, lower No. 1 panel, LH lower panel and No. 2 heater to register duct (See Pub. No. RM616E on page BO-127).
- (b) Remove the steering wheel pad, steering wheel lower No. 2 and No. 3 covers, steering wheel, combination switch, column upper and lower covers, steering column assembly and thrust stopper (See Pub. No. RM616E on page SR-13 or SR-29).
- (c) Disconnect the connector from the stop light switch.
- (d) Loosen the stop light switch lock nut and remove the stop light switch.
- (e) Loosen the push rod lock nut.
- (f) Adjust the pedal height by turning the pedal push rod.
- (g) Tighten the push rod lock nut.
Torque: 25 N·m (260 kgf·cm, 19 ft·lbf)
- (h) Install the stop light switch.
- (i) Connect the connector to the stop light switch.
- (j) Push in the brake pedal 5 – 15 mm (0.20 – 0.59 in.), turn the stop light switch to lock the nut in the position where the stop light goes off.
- (k) After installation, push in the brake pedal 5 – 15 mm (0.20 – 0.59 in.), check that stop light lights up.
- (l) After adjusting the pedal height, check the pedal free play.
- (m) Install the thrust stopper, steering column assembly, column upper and lower covers, combination switch, steering wheel, steering wheel lower No. 2 and No. 3 covers, and steering wheel pad (See Pub. No. RM616E on page SR-24 or SR-37).
- (n) Install the No. 2 heater to register duct, LH lower panel, lower No. 1 panel, cowl side trim and scuff plate (See Pub. No. RM616E on page BO-133).

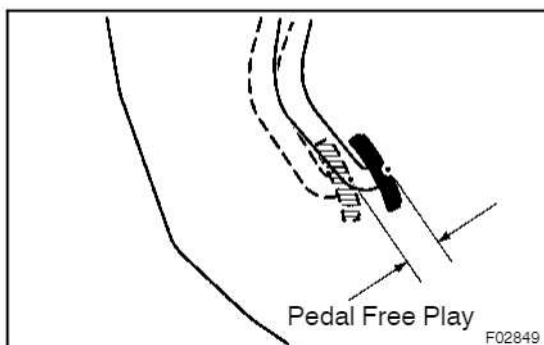

3. CHECK PEDAL FREE PLAY

- (a) Stop the engine and depress the brake pedal more than 40 times until there is no more pressure left in the booster.
- (b) Push in the pedal by hand until the second point of resistance begins to be felt, then measure the distance, as shown.

Pedal free play: 1.0 – 6.0 mm (0.039 – 0.236 in.)

If incorrect, check the stop light switch clearance. If the clearance is OK, then troubleshoot the brake system.

Stop light switch clearance: 1.9 mm (0.075 in.)

HINT:

The freeplay to the 1st point of resistance is due to the play between the clevis, pedal link and pin. It is 1.0 – 6.0 mm (0.039 – 0.236 in.) on the pedal.

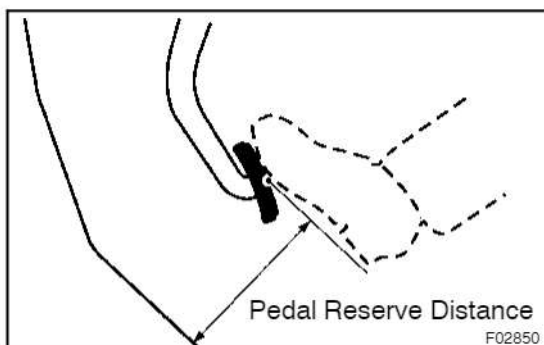

4. CHECK PEDAL RESERVE DISTANCE

- (a) Remove the floor carpet.
 - (b) Release the parking brake.
- With the engine running, depress the pedal and measure the pedal reserve distance, as shown.

Pedal reserve distance at 490 N (50 kgf, 110.1 lbf):

LHD: More than 116 mm (4.57 in.)

RHD: More than 121 mm (4.76 in.)

If the reserve distance is incorrect, troubleshoot the brake system.

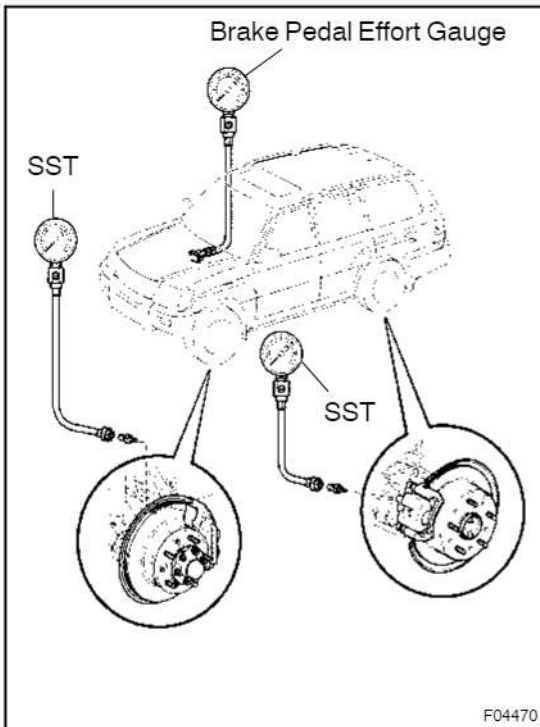

HYDRAULIC BRAKE BOOSTER ON-VEHICLE INSPECTION

BR128-02

1. CHECK HYDRAULIC BRAKE BOOSTER FLUID PRESSURE CHANGE

- (a) Inspect the battery voltage.
Battery voltage: 10 - 14 V
- (b) Turn the ignition switch OFF, depress the brake pedal more than 40 times.

HINT:

When a pressure in power supply system is released, reaction force becomes light and stroke becomes longer.

- (c) Install LSPV gauge (SST) and brake pedal effort gauge, bleed air.

SST 09709-29018

- (d) When booster does not operate:
Depress the brake pedal and check fluid pressure.

At 245 N (25 kgf, 55 lbf):

Front brake pressure	Rear brake pressure
2,697 kPa (27.5 kgf/cm ² , 391 psi) or more	0 kPa (0 kgf/cm ² , 0 psi)

At 343 N (35 kgf, 77 lbf):

Front brake pressure	Rear brake pressure
3,923 kPa (40 kgf/cm ² , 569 psi) or more	0 kPa (0 kgf/cm ² , 0 psi)

- (e) w/ ABS only, when booster operate:
 - (1) Turn the ignition switch ON and wait until the pump motor has stopped.
 - (2) Depress the brake pedal and check fluid pressure.

At 49 N (5 kgf, 11 lbf):

Front brake pressure	Rear brake pressure
1,618 - 2,795 kPa (16.5 - 28.5 kgf/cm ² , 235 - 405 psi)	1,716 - 2,893 kPa (17.5 - 29.5 kgf/cm ² , 249 - 420 psi)

At 98 N (10 kgf, 22 lbf):

Front brake pressure	Rear brake pressure
4,413 - 5,590 kPa (45 - 57 kgf/cm ² , 640 - 811 psi)	3,187 - 4,364 kPa (32.5 - 44.5 kgf/cm ² , 462 - 633 psi)

At 147 N (15 kgf, 33 lbf):

Front brake pressure	Rear brake pressure
7,208 - 8,385 kPa (73.5 - 85.5 kgf/cm ² , 1,045 - 1,216 psi)	4,609 - 5,786 kPa (47 - 59 kgf/cm ² , 668 - 839 psi)

At 196 N (20 kgf, 44 lbf):

Front brake pressure	Rear brake pressure
9,905 - 11,082 kPa (101 - 113 kgf/cm ² , 1,437 - 1,607 psi)	6,031 - 7,208 kPa (61.5 - 73.5 kgf/cm ² , 875 - 1,045 psi)

- (f) w/ ABS & TRC & VSC ECU only, when booster operate:
- (1) Turn the ignition switch ON and wait until the pump motor has stopped.
 - (2) Depress the brake pedal and check fluid pressure.

At 49 N (5 kgf, 11 lbf):

Front brake pressure	Rear brake pressure
1,618 – 2,795 kPa (16.5 – 28.5 kgf/cm ² , 235 – 405 psi)	1,716 – 2,893 kPa (17.5 – 29.5 kgf/cm ² , 249 – 420 psi)

At 98 N (10 kgf, 22 lbf):

Front brake pressure	Rear brake pressure
4,413 – 5,590 kPa (45 – 57 kgf/cm ² , 640 – 811 psi)	4,609 – 5,786 kPa (47 – 59 kgf/cm ² , 668 – 839 psi)

At 147 N (15 kgf, 33 lbf):

Front brake pressure	Rear brake pressure
7,208 – 8,385 kPa (73.5 – 85.5 kgf/cm ² , 1,045 – 1,216 psi)	7,502 – 8,679 kPa (76.5 – 88.5 kgf/cm ² , 1,088 – 1,259 psi)

At 196 N (20 kgf, 44 lbf):

Front brake pressure	Rear brake pressure
9,905 – 11,082 kPa (101 – 113 kgf/cm ² , 1,437 – 1,607 psi)	10,346 – 11,523 kPa (105.5 – 117.5 kgf/cm ² , 1,501 – 1,671 psi)

2. w/ ABS only,

in case of using hand-held tester:

INSPECT HYDRAULIC BRAKE BOOSTER OPERATION

- (a) Inspect the battery voltage.
Battery voltage: 10 – 14 V
- (b) Turn the ignition switch OFF, depress the brake pedal more than 40 times.

HINT:

When a pressure in power supply system is released, reaction force becomes light and stroke becomes longer.

- (c) Turn the ignition switch ON, check the pump motor operation noise.

If the pump motor does not operate, check and replace the wire harness and pump motor ([See page BR-32](#)).



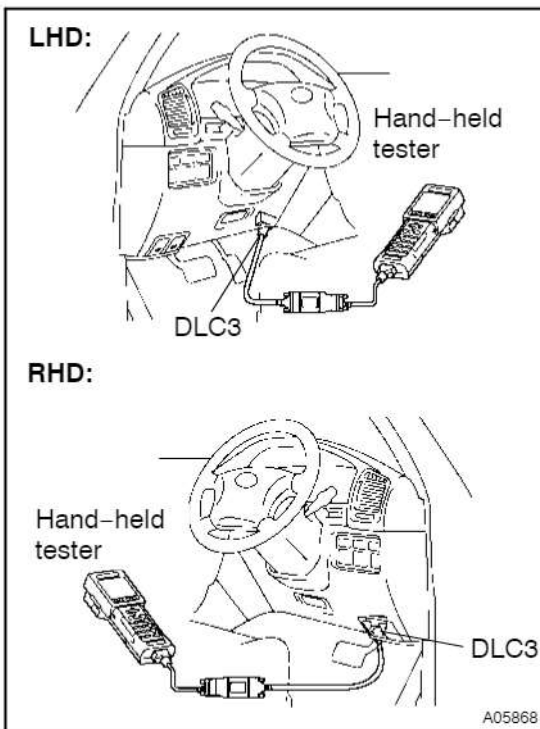

- (d) Connect the hand-held tester.
- (1) Connect the hand-held tester to the DLC3.
 - (2) Turn the ignition switch ON.
 - (3) Select the "ACTIVE TEST" mode on the hand-held tester.

HINT:

- Please refer to the hand-held tester operator's manual for further details.
 - To protect the solenoids, hand-held tester turns OFF automatically for 2 sec. after every solenoid has been turned ON.
- (e) Inspect the front ABS switching solenoid operation.
- (1) Select "SA1" and "SA2" on the hand-held tester.
 - (2) With "SA1" and "SA2" turned ON simultaneously with the hand-held tester, depress the brake pedal with stable force and check that the pedal cannot be depressed.

HINT:

To protect the solenoids, hand-held tester turns OFF automatically for 2 sec. after every solenoid has been turned ON. If the pedal can be depressed, replace the hydraulic brake booster.

NOTICE:

When operating it continuously, set the interval of more than 20 sec.

- (3) Once, release the brake pedal.
- (4) When the solenoids are OFF, after depressing the brake pedal again and check that the brake pedal can be depressed.

If the pedal cannot be depressed, replace the hydraulic brake booster.

- (f) Inspect the front ABS solenoid operation.
- (1) Select "SFRH" and "SFLH" on the hand-held tester.
 - (2) With "SFRH" and "SFLH" turned ON simultaneously with the hand-held tester, depress the brake pedal with stable force and check that the brake pedal cannot be depressed.

HINT:

To protect the solenoids, hand-held tester turns OFF automatically for 2 sec. after every solenoid has been turned ON. If the pedal can be depressed, replace the hydraulic brake booster.

- (3) Once, release the brake pedal when the solenoids are OFF, check that the brake pedal can be depressed.

If the pedal cannot be depressed, replace the hydraulic brake booster.

- (4) Once, release the brake pedal. After depressing and holding the brake pedal with stable force, turn the SFRH and SFRR solenoids ON simultaneously.

HINT:

To protect the solenoids, hand-held tester turns OFF automatically for 2 sec. after every solenoid has been turned ON.

- (5) When the solenoids are OFF, check that the brake pedal can be depressed.

If the pedal cannot be depressed, replace the hydraulic brake booster.

- (6) Once, release the brake pedal. After depressing and holding the brake pedal with stable force, turn the SFLH and SFLR solenoids ON simultaneously.

HINT:

To protect the solenoids, hand-held tester turns OFF automatically for 2 sec. after every solenoid has been turned ON.

- (7) Once release the brake pedal when the solenoids are OFF, check that the brake pedal can be depressed.

If the pedal cannot be depressed, replace the hydraulic brake booster.

- (g) Jack up and support the vehicle.
- (h) Release the parking brake lever.
- (i) Inspect the rear ABS solenoid.
 - (1) Select the "SRH" on the hand-held tester.
 - (2) Turn the "SRH" ON with the hand-held tester and depress the brake pedal with stable force, and rotate the right rear wheel by hand and check it.

HINT:

- To protect the solenoids, hand-held tester turns OFF automatically for 2 sec. after every solenoid has been turned ON.
- When rotating the wheel fast, the fail-safe function is activated and judgement cannot be made properly. So rotate the wheel as slowly as possible.
- When solenoid is OFF, the wheel might stop temporarily. However if the wheel rotates again, the function works normally.

If the rear wheels stop, replace the hydraulic brake booster.

- (3) Once, release the brake pedal and turn the "SRH" OFF, after depressing the brake pedal with stable force and stop the rear right wheel by hand and check it.

If the rear wheel rotate, replace the hydraulic brake booster.

- (4) Depress the pedal with stable force, then turn the "SRH" and "SRR" ON simultaneously.
- (5) When the solenoids are ON, rotate the rear wheel by hand and check it.

HINT:

- To protect the solenoids, hand-held tester turns OFF automatically for 2 sec. after every solenoid has been turned ON.

- When rotating the wheel fast, the fail-safe function is activated and judgement cannot be made properly. So rotate the wheel as slowly as possible.

- (j) Lower the vehicle.
- (k) Disconnect the hand-held tester.

**3. w/ ABS & TRC & VSC only,
in case of using hand-held tester:**

INSPECT HYDRAULIC BRAKE BOOSTER OPERATION

- (a) Inspect the battery voltage.
Battery voltage: 10 – 14 V
- (b) Turn the ignition switch OFF, depress the brake pedal more than 40 times.

HINT:

When a pressure in power supply system is released, reaction force becomes light and stroke becomes longer.

- (c) Check that the brake pedal becomes light to depress. If the pedal does not become to be light to depress, check and replace the brake line and hydraulic brake booster.
- (d) Turn the ignition switch ON, check the pump motor operation noise.

If the pump motor does not operate, check and replace the wire harness and pump motor (See page BR-32).

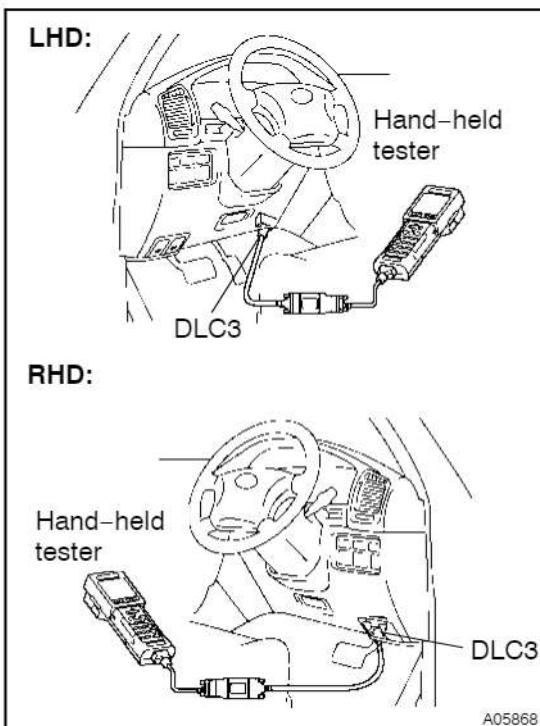

- (e) Connect the hand-held tester.
 - (1) Connect the hand-held tester to the DLC3.
 - (2) Turn the ignition switch ON.
 - (3) Select the "ACTIVE TEST" mode on the hand-held tester.

HINT:

- Please refer to the hand-held tester operator's manual for further details.
 - To protect the solenoids, hand-held tester turns OFF automatically 2 sec. after every solenoid has been turned ON.
- (f) Inspect the front TRC & VSC solenoid operation.
 - (1) Select "SA1" and "SA2" on the hand-held tester.
 - (2) With "SA1" and "SA2" turned ON simultaneously with the hand-held tester, depress the brake pedal with stable force and check that the pedal cannot be depressed.

HINT:

To protect the solenoids, hand-held tester turns OFF automatically 2 sec. after every solenoid has been turned ON.

If the pedal can be depressed, replace the hydraulic brake booster.

NOTICE:

When operating it continuously, set the interval of more than 20 sec.

- (3) Once, release the brake pedal.
- (4) When the solenoids are OFF, after depressing the brake pedal again and check that the brake pedal can be depressed.

If the pedal cannot be depressed, replace the hydraulic brake booster.

- (g) Inspect the front ABS solenoid operation.
 - (1) Select "SFRH" and "SFLH" on the hand-held tester.
 - (2) With "SFRH" and "SFLH" turned ON simultaneously with the hand-held tester, depress the brake pedal with stable force and check that the brake pedal cannot be depressed.

HINT:

To protect the solenoids, hand-held tester turns OFF automatically 2 sec. after every solenoid has been turned ON.

If the pedal can be depressed, replace the hydraulic brake booster.

- (3) Once, release the brake pedal when the solenoids are OFF, check that the brake pedal can be depressed.

If the pedal cannot be depressed, replace the hydraulic brake booster.

- (4) Once, release the brake pedal. After depressing and holding the brake pedal with stable force, turn the SFRH and SFRR solenoids ON simultaneously.

HINT:

To protect the solenoids, hand-held tester turns OFF automatically 2 sec. after every solenoid has been turned ON.

- (5) When the solenoids are OFF, check that the brake pedal can be depressed.

If the pedal cannot be depressed, replace the hydraulic brake booster.

- (6) Once, release the brake pedal. After depressing and holding the brake pedal with stable force, turn the SFLH and SFLR solenoids ON simultaneously.

HINT:

To protect the solenoids, hand-held tester turns OFF automatically 2 sec. after every solenoid has been turned ON.

- (7) When the solenoids are OFF, check that the brake pedal can be depressed.

If the pedal cannot be depressed, replace the hydraulic brake booster.

- (h) Jack up and support the vehicle.
- (i) Release the parking brake lever.
- (j) Shift the transfer shift lever to "N" range and check that the rear wheels by rotating them by hand.
- (k) Inspect the rear TRC & VSC solenoid operation.
 - (1) Select the "SA3" and "STR" on the hand-held tester.
 - (2) Turn the "SA3" and "STR" ON simultaneously with the hand-held tester, and check that the rear wheel does not rotate by hand.

HINT:

When rotating the wheel fast, the fail-safe function is activated and judgement cannot be made properly. So rotate the wheel as slowly as possible.

If the rear wheels rotate, replace the hydraulic brake booster.

- (3) Turn the "SA3" and "STR" OFF simultaneously, and check that the rear wheels by rotating them by hand.

HINT:

- To protect the solenoids, hand-held tester turns OFF automatically 2 sec. after every solenoid has been turned ON.
- When rotating the wheel fast, the fail-safe function is activated and judgement cannot be made properly. So rotate the wheel as slowly as possible.

NOTICE:

When operating it continuously, set the interval of more than 20 sec.

If the rear wheels stop, replace the hydraulic brake booster.

- (l) Inspect the right rear ABS solenoid.
 - (1) Select the "SA3", "STR" and "SRRH", on the hand-held tester.
 - (2) Turn the "SA3", "STR" and "SRRH" ON simultaneously with the hand-held tester, and check that the right rear wheel by rotating it by hand.

HINT:

- To protect the solenoids, hand-held tester turns OFF automatically 2 sec. after every solenoid has been turned ON.
- When rotating the wheel fast, the fail-safe function is activated and judgement cannot be made properly. So rotate the wheel as slowly as possible.
- When solenoid is OFF, the wheel might stop temporarily. However if the wheel rotates again, the function works normally.

If the rear wheels stop, replace the hydraulic brake booster.

- (3) Turn the "SA3", "STR" and "SRRH" OFF, and check that the right rear wheel by rotating it by hand.

HINT:

- To protect the solenoids, hand-held tester turns OFF automatically 2 sec. after every solenoid has been turned ON.
- When rotating the wheel fast, the fail-safe function is activated and judgement cannot be made properly. So rotate the wheel as slowly as possible.

If the right rear wheel stop, replace the hydraulic brake booster.

- (4) Depress the pedal with stable force, then turn the "SRRH" and "SRRR" ON simultaneously.
- (5) When the solenoids are ON, check that the right rear wheel by rotating it by hand.

(m) Inspect the left rear ABS solenoid operation.

- (1) Select the "SA3", "STR" and "SRLH" on the hand-held tester.
- (2) Turn the "SA3", "STR" and "SRLH" ON with hand-held tester, and check that the left rear wheel by rotating it by hand.

HINT:

When rotating the wheel fast, the fail-safe function is activated and judgement cannot be made properly. So rotate the wheel as slowly as possible.

If the rear wheels stop, replace the hydraulic brake booster.

- (3) Turn the "SA3", "STR" and "SRLH" OFF and check that the left rear wheel by rotating it by hand.

HINT:

- To protect the solenoids, hand-held tester turns OFF automatically 2 sec. after every solenoid has been turned ON.
- When rotating the wheel fast, the fail-safe function is activated and judgement cannot be made properly. So rotate the wheel as slowly as possible.
- When solenoid is OFF, the wheel might stop temporarily. However if the wheel rotates again, the function works normally.

If the left rear wheel stop, replace the hydraulic brake booster.

- (4) Depress the pedal with stable force, then turn the "SRLH" and "SRLR" ON simultaneously.

HINT:

To protect the solenoids, hand-held tester turns OFF automatically 2 sec. after every solenoid has been turned ON.

- (5) When the solenoids are ON, check that the left rear wheel by rotating it by hand.

HINT:

When rotating the wheel fast, the fail-safe function is activated and judgement cannot be made properly. So rotate the wheel as slowly as possible.

- (n) Lower the vehicle.

- (o) Disconnect the hand-held tester.
4. **w/ ABS only,**
in case of using ABS actuator checker (SST):
INSPECT HYDRAULIC BRAKE BOOSTER OPERATION

- (a) Inspect the battery voltage.

Battery voltage: 10 - 14 V

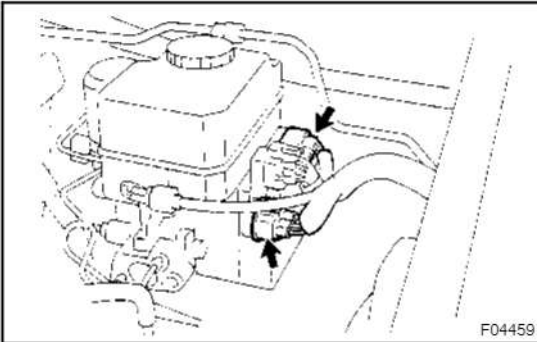

- (b) Disconnect the 2 connectors from hydraulic brake booster.
- (c) Connect the actuator checker (SST) to the hydraulic brake booster side wire harness via the sub-wire harness (SST), as shown in the following chart.
 SST 09990-00150, 09990-00480

HINT:

Connect the connector with the label of "FRONT" attached to the connector of actuator checker.

- (d) Connect the red cable of the checker to the battery positive (+) terminal and the black cable to the negative (-) terminal.

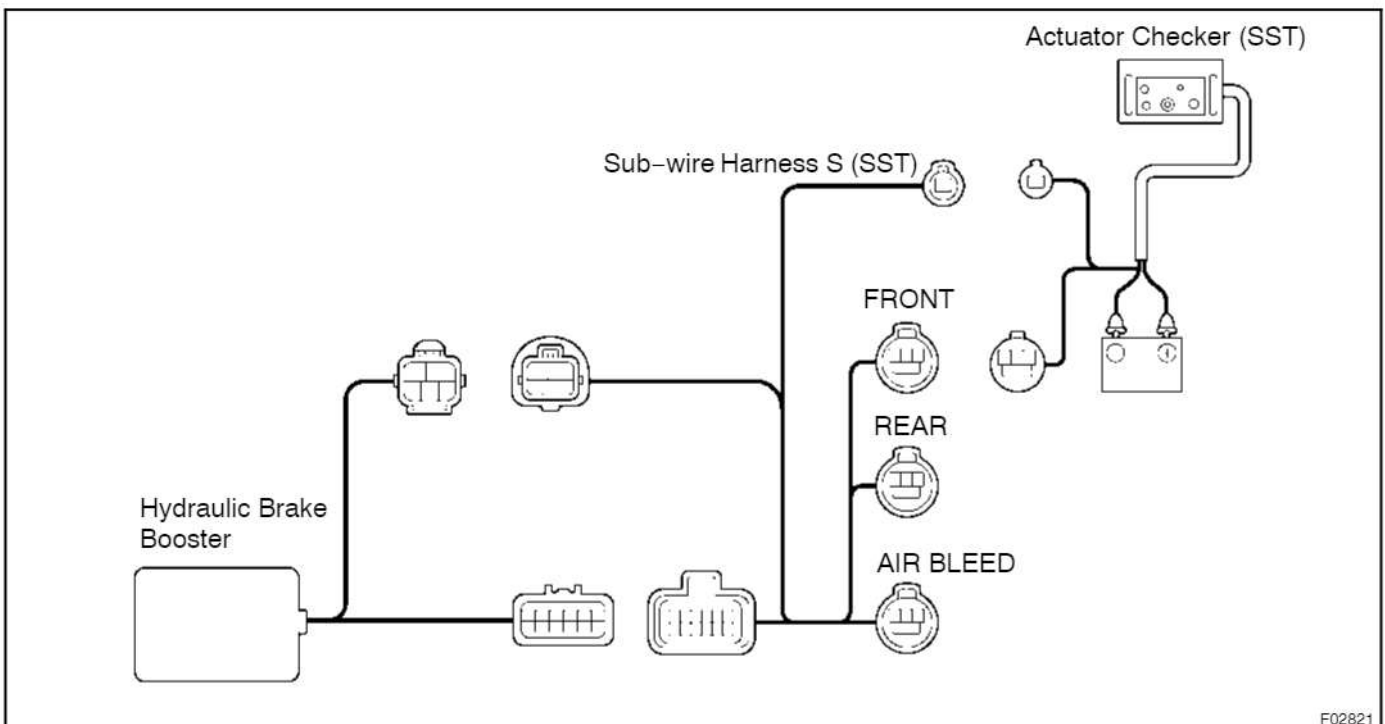

- (e) Place "SHEET G" (SST) of "FRONT" on actuator checker.
SST 09990-00240
- (f) Turn the ignition switch OFF, depress the brake pedal more than 40 times.

HINT:

When a pressure in power supply system is released, reaction force becomes light and stroke becomes longer.

- (g) Turn the ignition switch ON, check the pump motor operation noise.

If the pump motor does not operate, check and replace the wire harness and pump motor (See page BR-32).

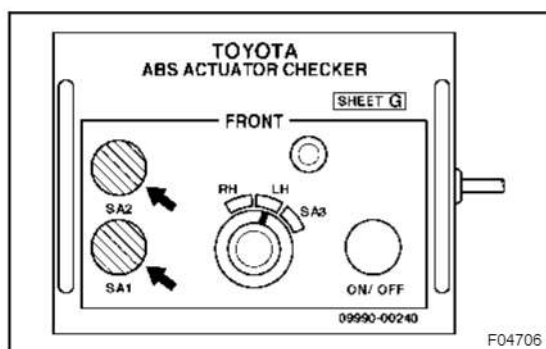

- (h) Inspect the front switching solenoid operation.
 - (1) Push in and hold the "SA1" and "SA2" switches simultaneously, depress strongly and hold the brake pedal with stable force.

NOTICE:

Do not keep the "SA1" and "SA2" pushed down for more than 10 sec. When operating it continuously, set the interval of more than 20 sec.

- (2) Check that the brake pedal cannot be depressed. If the pedal can be depressed, replace the hydraulic brake booster.
- (3) Release the "SA1" switch and check that the brake pedal can be depressed.

If the pedal cannot be depressed, replace the hydraulic brake booster.

- (4) Release the "SA2" switch and check that the brake pedal can be depressed.

If the pedal cannot be depressed, replace the hydraulic brake booster.

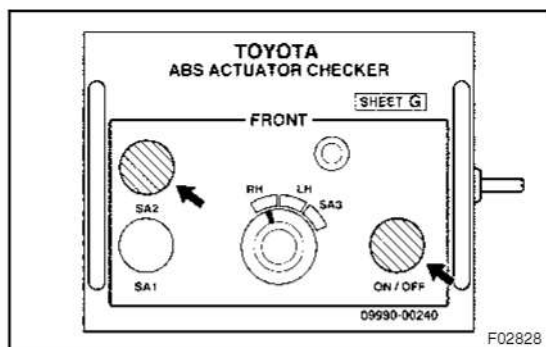

- (i) Inspect the right front solenoid operation.
 - (1) Turn the selector switch to "RH" position.
 - (2) Push and hold in the MAIN push switch and "SA2" switch simultaneously depress and hold the brake pedal with stable force.

NOTICE:

Do not keep the MAIN push switch and "SA2" switch pushed down for more than 10 sec. When operating it continuously, set the interval of more than 20 sec.

(3) Check that the brake pedal cannot be depressed. If the pedal can be depressed, replace the hydraulic brake booster.

(4) Release the MAIN push switch and "SA2" switch simultaneously and check that the brake pedal can be depressed.

If the pedal cannot be depressed, replace the hydraulic brake booster.

(5) Release the brake pedal.

(6) Depress and hold the brake pedal with stable force, push and hold in MAIN push switch.

NOTICE:

Do not keep the MAIN push switch pushed down for more than 10 sec. When operating it continuously, set the interval of more than 20 sec.

(7) Check that the brake pedal cannot be depressed. If the pedal can be depressed, replace the hydraulic brake booster.

(8) Release the MAIN push switch, and check that the brake pedal can be depressed.

If the pedal cannot be depressed, replace the hydraulic brake booster.

(9) Release the brake pedal.

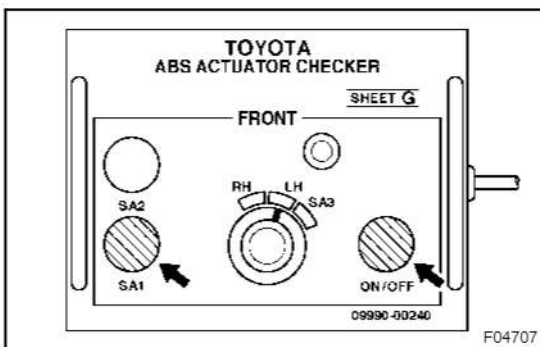
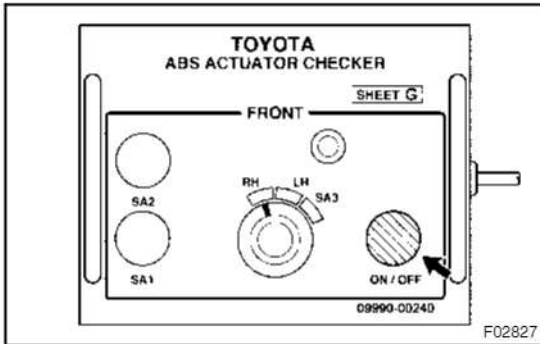

(j) Inspect the left front solenoid operation.

(1) Turn the selector switch to "LH" position.

(2) Push and hold in the MAIN push switch and "SA1" switch simultaneously, depress and hold the brake pedal with stable force.

NOTICE:

Do not keep the MAIN push switch and "SA1" switch pushed down for more than 10 sec. When operating it continuously, set the interval of more than 20 sec.

(3) Check that the brake pedal cannot be depressed. If the pedal can be depressed, replace the hydraulic brake booster.

(4) Release the MAIN push switch and "SA1" switch simultaneously, and check that the brake pedal can be depressed.

If the pedal cannot be depressed, replace the hydraulic brake booster.

(5) Release the brake pedal.

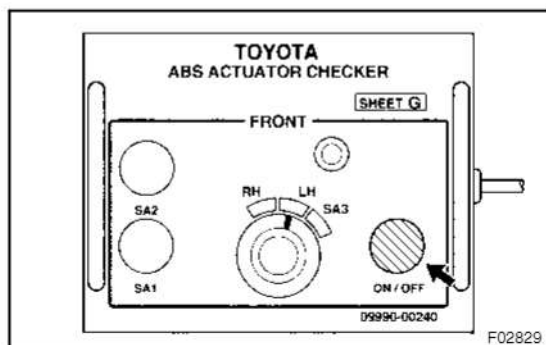

- (6) Depress and hold the brake pedal with stable force, push and hold in MAIN push switch.

NOTICE:

Do not keep the MAIN push switch pushed down for more than 10 sec. When operating it continuously, set the interval of more than 20 sec.

- (7) Check that the brake pedal cannot be depressed. If the pedal can be depressed, replace the hydraulic brake booster.

- (8) Release the MAIN push switch, and check that the brake pedal can be depressed.

If the pedal cannot be depressed, replace the hydraulic brake booster.

- (9) Release the brake pedal.

- (k) Turn the ignition switch OFF, then reconnect the connector of sub-wire harness from the one with label of "FRONT" to "REAR".

- (l) Place "SHEET G" of "REAR" on the actuator checker.

- (m) Jack up and support the vehicle.

- (n) Start the engine and run it at idle.

- (o) Inspect the rear solenoid operation.

- (1) Turn the selector switch to "RH" position.

- (2) Depress the brake pedal several times and release the pedal when the pump begins rotating. Wait until the pump stops.

- (3) Turn the ignition switch OFF.

- (4) Depress the brake pedal with a force of 343 N (35 kgf, 77 lbf), record the fluid surface in the reservoir tank of the hydraulic brake booster.

- (5) Press the MAIN push switch for 10 sec., and check that the fluid surface in the reservoir tank of the hydraulic brake booster does not rise up at this time.

If the fluid surface level rises up, replace the hydraulic brake booster.

NOTICE:

Do not press MAIN push switch for more than 10 sec. When operating the switch continuously, do it an interval of more than 20 sec.

- (6) Release the brake pedal and check that brake pedal is not hard to depress.

If pedal is hard to depress, replace the hydraulic brake booster.

- (7) Start the engine and run it at idle.

- (8) Depress the brake pedal.

- (9) Release the parking brake lever and shift the shift lever to "L" range.

- (10) Once, release the brake pedal. After depressing the brake pedal with stable force, then push and hold MAIN push switch.

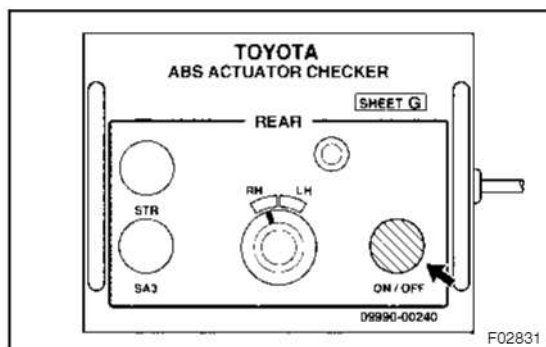

(11) Check that the right rear wheel rotates.

If the right rear wheels stops, replace the hydraulic brake booster.

- (p) Stop the engine and lower the vehicle.
- (q) Remove the "SHEET G" (SST) and disconnect the actuator checker (SST) and sub-wire harness (SST) from the hydraulic brake booster.
- (r) Connect the 2 connectors to the actuator.
- (s) Clear the DTC (See page DI-4).

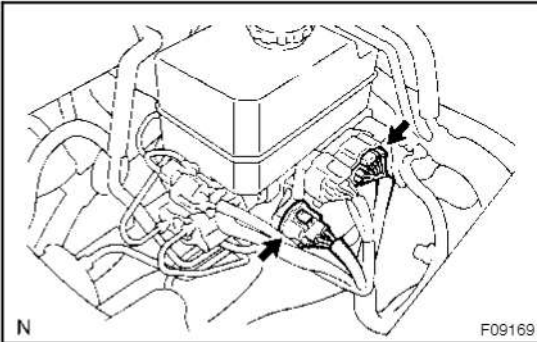

5. **w/ ABS & TRC & VSC only,**
in case of using ABS actuator checker (SST):
INSPECT HYDRAULIC BRAKE BOOSTER OPERATION

- (a) Inspect the battery voltage.
Battery voltage: 10 - 14 V
- (b) Disconnect the 2 connectors from hydraulic brake booster.
- (c) Connect the actuator checker (SST) to the hydraulic brake booster side wire harness via the sub-wire harness S (SST), as shown in the following chart.
 SST 09990-00150, 09990-00480

HINT:

Connect the connector with the label of "FRONT" attached to the connector of actuator checker.

- (d) Connect the red cable of the checker to the battery positive (+) terminal and the black cable to the negative (-) terminal.

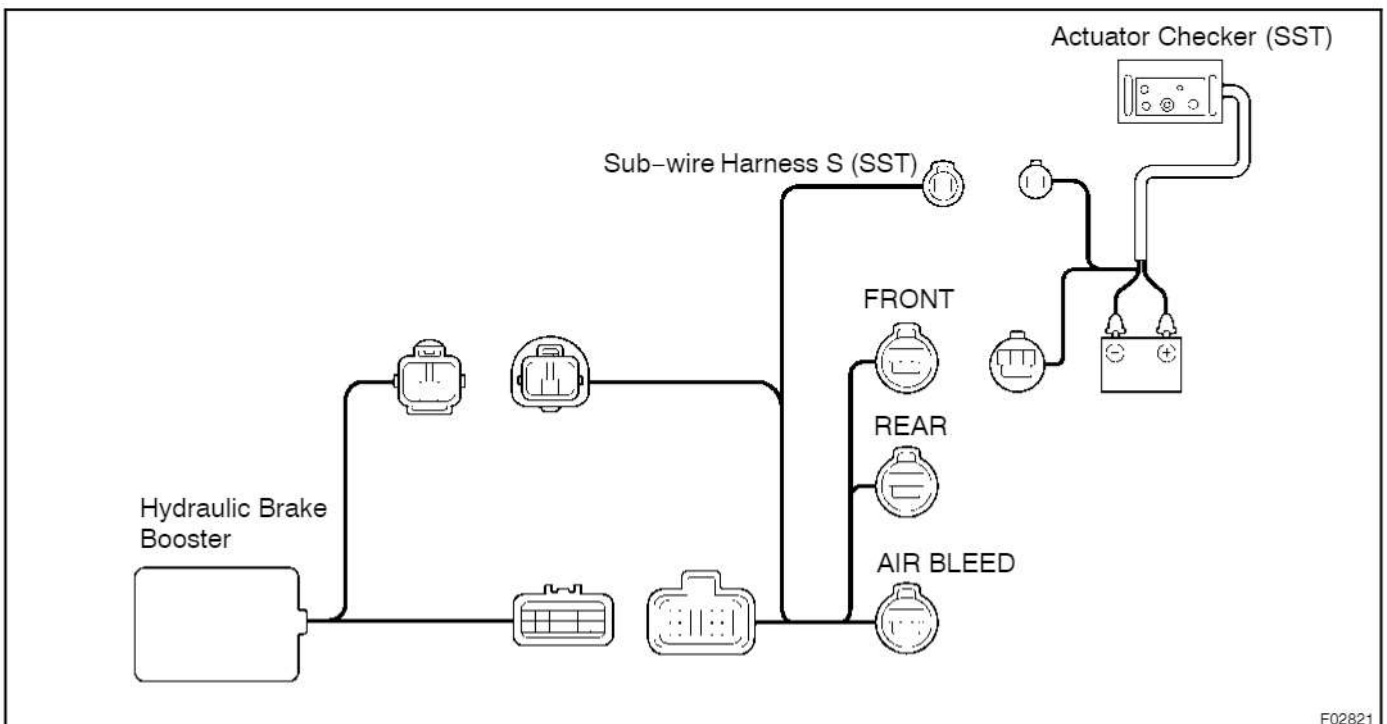

- (e) Place "SHEET G" (SST) of "FRONT" on actuator checker.
SST 09990-00240
- (f) Turn the ignition switch OFF, depress the brake pedal more than 40 times.

HINT:

When a pressure in power supply system is released, reaction force becomes light and stroke becomes longer.

- (g) Check that the brake pedal becomes light to depress. If the pedal does not become to be light to depress, check and replace the brake line and hydraulic brake booster.

- (h) Turn the ignition switch ON, check the pump motor operation noise.

If the pump motor does not operate, check and replace the wire harness and pump motor (See page BR-32).

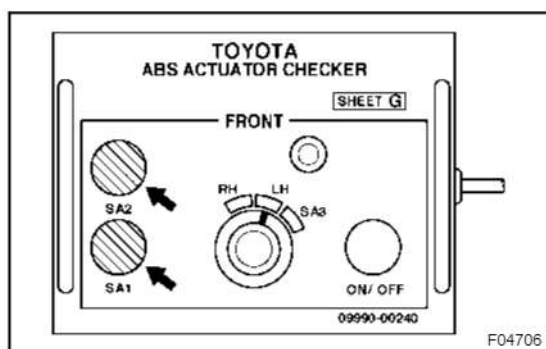

- (i) Inspect the front TRC & VSC solenoid operation.
 - (1) Push in and hold the "SA1" and "SA2" switches simultaneously, depress strongly and hold the brake pedal with stable force.

NOTICE:

Do not keep the "SA1" and "SA2" pushed down for more than 10 sec. When operating it continuously, set the interval of more than 20 sec.

- (2) Check that the brake pedal cannot be depressed. If the pedal can be depressed, replace the hydraulic brake booster.
- (3) Release the "SA1" switch and check that the brake pedal can be depressed.

If the pedal cannot be depressed, replace the hydraulic brake booster.

- (4) Release the "SA2" switch and check that the brake pedal can be depressed.

If the pedal cannot be depressed, replace the hydraulic brake booster.

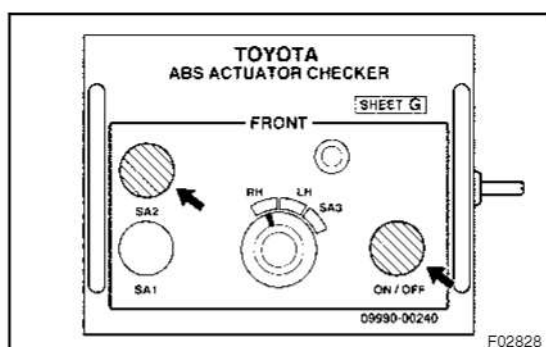

- (j) Inspect the right front ABS solenoid operation.
 - (1) Turn the selector switch to "RH" position.
 - (2) Push and hold in the MAIN push switch and "SA2" switch simultaneously, depress and hold the brake pedal with stable force.

NOTICE:

Do not keep the MAIN push switch and "SA2" switch pushed down for more than 10 sec. When operating it continuously, set the interval of more than 20 sec.

(3) Check that the brake pedal cannot be depressed. If the pedal can be depressed, replace the hydraulic brake booster.

(4) Release the MAIN push switch and "SA2" switch simultaneously and check that the brake pedal can be depressed.

If the pedal cannot be depressed, replace the hydraulic brake booster.

(5) Release the brake pedal.

(6) Depress and hold the brake pedal with stable force, push and hold in MAIN push switch.

NOTICE:

Do not keep the MAIN push switch pushed down for more than 10 sec. When operating it continuously, set the interval of more than 20 sec.

(7) Check that the brake pedal cannot be depressed. If the pedal can be depressed, replace the hydraulic brake booster.

(8) Release the MAIN push switch, and check that the brake pedal can be depressed.

If the pedal cannot be depressed, replace the hydraulic brake booster.

(9) Release the brake pedal.

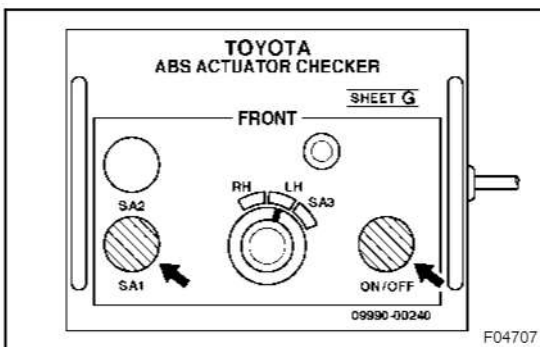
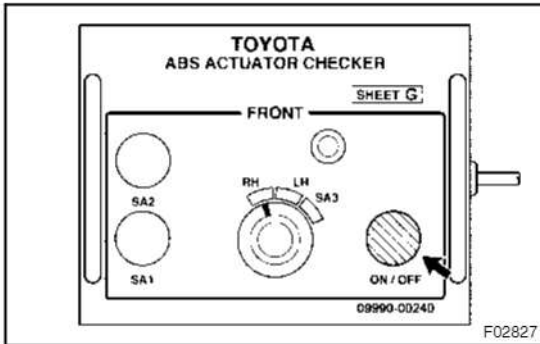

(k) Inspect the left front ABS solenoid operation.

(1) Turn the selector switch to "LH" position.

(2) Push and hold in the MAIN push switch and "SA1" switch simultaneously, depress and hold the brake pedal with stable force.

NOTICE:

Do not keep the MAIN push switch and "SA1" switch pushed down for more than 10 sec. When operating it continuously, set the interval of more than 20 sec.

(3) Check that the brake pedal cannot be depressed. If the pedal can be depressed, replace the hydraulic brake booster.

(4) Release the MAIN push switch and "SA1" switch simultaneously, and check that the brake pedal can be depressed.

If the pedal cannot be depressed, replace the hydraulic brake booster.

(5) Release the brake pedal.

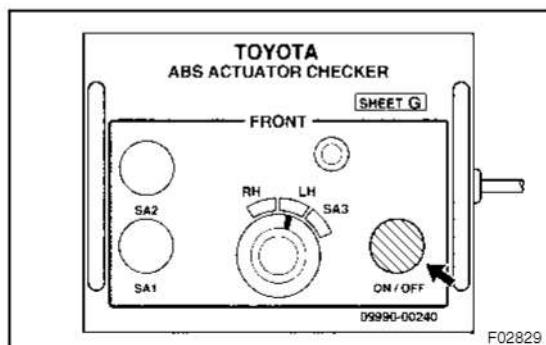

- (6) Depress and hold the brake pedal with stable force, push and hold in MAIN push switch.

NOTICE:

Do not keep the MAIN push switch pushed down for more than 10 sec. When operating it continuously, set the interval of more than 20 sec.

- (7) Check that the brake pedal cannot be depressed. If the pedal can be depressed, replace the hydraulic brake booster.

- (8) Release the MAIN push switch, and check that the brake pedal can be depressed.

If the pedal cannot be depressed, replace the hydraulic brake booster.

- (9) Release the brake pedal.

- (l) Turn the ignition switch OFF, then reconnect the connector of sub-wire harness from the one with label of "FRONT" to "REAR".

- (m) Place "SHEET G" of "REAR" on the actuator checker.

- (n) Jack up and support the vehicle.

- (o) Start the engine and run it at idle.

- (p) Inspect the rear TRC & VSC solenoid.

- (1) Release the parking brake lever and shift the shift lever to "L" range.

- (2) Push and hold the "SA3" switch and "STR" switch simultaneously.

NOTICE:

- **Do not keep the "STR" switch pushed down for more than 10 sec.**
- **Do not keep the "SA3" switch pushed down for more than 5 sec.**
- **When operating it continuously, set the interval of more than 20 sec.**

- (3) Check that the rear wheels stop.

If the rear wheels rotate, replace the hydraulic brake booster.

- (4) Release the "SA3" switch and "STR" switch simultaneously.

- (5) Check that the rear wheels rotate.

If the rear wheels stop, replace the hydraulic brake booster.

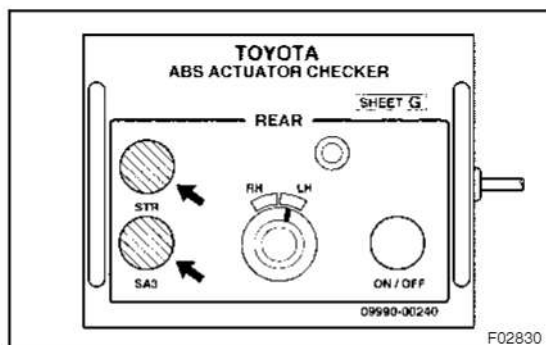

- (q) Inspect the right rear ABS solenoid.

- (1) Turn the selector switch to "RH" position.

- (2) Depress the brake pedal several times and release the brake pedal when the pump begins rotating. Wait until the pump stops.

- (3) Turn the ignition switch OFF.

- (4) Depress the brake pedal with a force of 343 N (35 kgf, 77 lbf), record the fluid surface in the reservoir tank of the hydraulic brake booster.

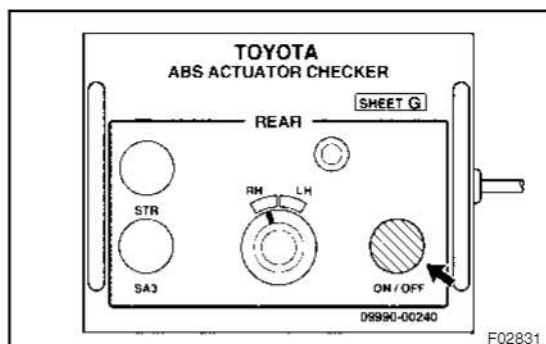

- (5) Press the MAIN push switch for 10 sec., and check that the fluid surface in the reservoir tank of the hydraulic brake booster does not rise up at this time.

If the fluid surface level rises up, replace the hydraulic brake booster.

NOTICE:

Do not press MAIN push switch for more than 10 sec. When operating the switch continuously, do it an interval of more than 20 sec.

- (6) Start the engine and run it at idle.
- (7) Depress the brake pedal.
- (8) Release the parking brake lever and shift the shift lever to "L" range.
- (9) Once, release the brake pedal. After depressing the brake pedal with stable force, then push and hold MAIN push switch.
- (10) Check that the right rear wheel rotates.

If the right rear wheel stops, replace the hydraulic brake booster.

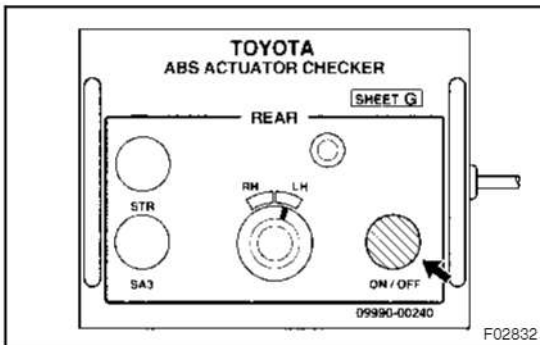

- (r) Inspect the left rear ABS solenoid.
 - (1) Turn the selector switch to "LH" position.
 - (2) Depress the brake pedal several times and release the brake pedal when the pump begins rotating. Wait until the pump stops.
 - (3) Turn the ignition switch OFF.
 - (4) Depress the brake pedal with a force of 343 N (35 kgf, 77 lbf), record the fluid surface in the reservoir tank of the hydraulic brake booster.
 - (5) Press the MAIN push switch for 10 sec., and check that the fluid surface in the reservoir tank of the hydraulic brake booster does not rise up at this time.

If the fluid surface level rises up, replace the hydraulic brake booster.

NOTICE:

Do not press MAIN push switch for more than 10 sec. When operating the switch continuously, do it an interval of more than 20 sec.

- (6) Start the engine and run it at idle.
- (7) Depress the brake pedal.
- (8) Release the parking brake lever and shift the shift lever to "L" range.
- (9) Once, release the brake pedal. After depressing the brake pedal with stable force, then push and hold MAIN push switch.
- (10) Check that the left rear wheel rotates.

If the left rear wheel stops, replace the hydraulic brake booster.

- (s) Stop the engine and lower the vehicle.

- (t) Remove the "SHEET G" (SST) and disconnect the actuator checker (SST) and sub-wire harness S (SST) from the hydraulic brake booster.
- (u) Connect the 2 connectors to the actuator.
- (v) Clear the DTC ([See page DI-4](#)).

COMPONENTS

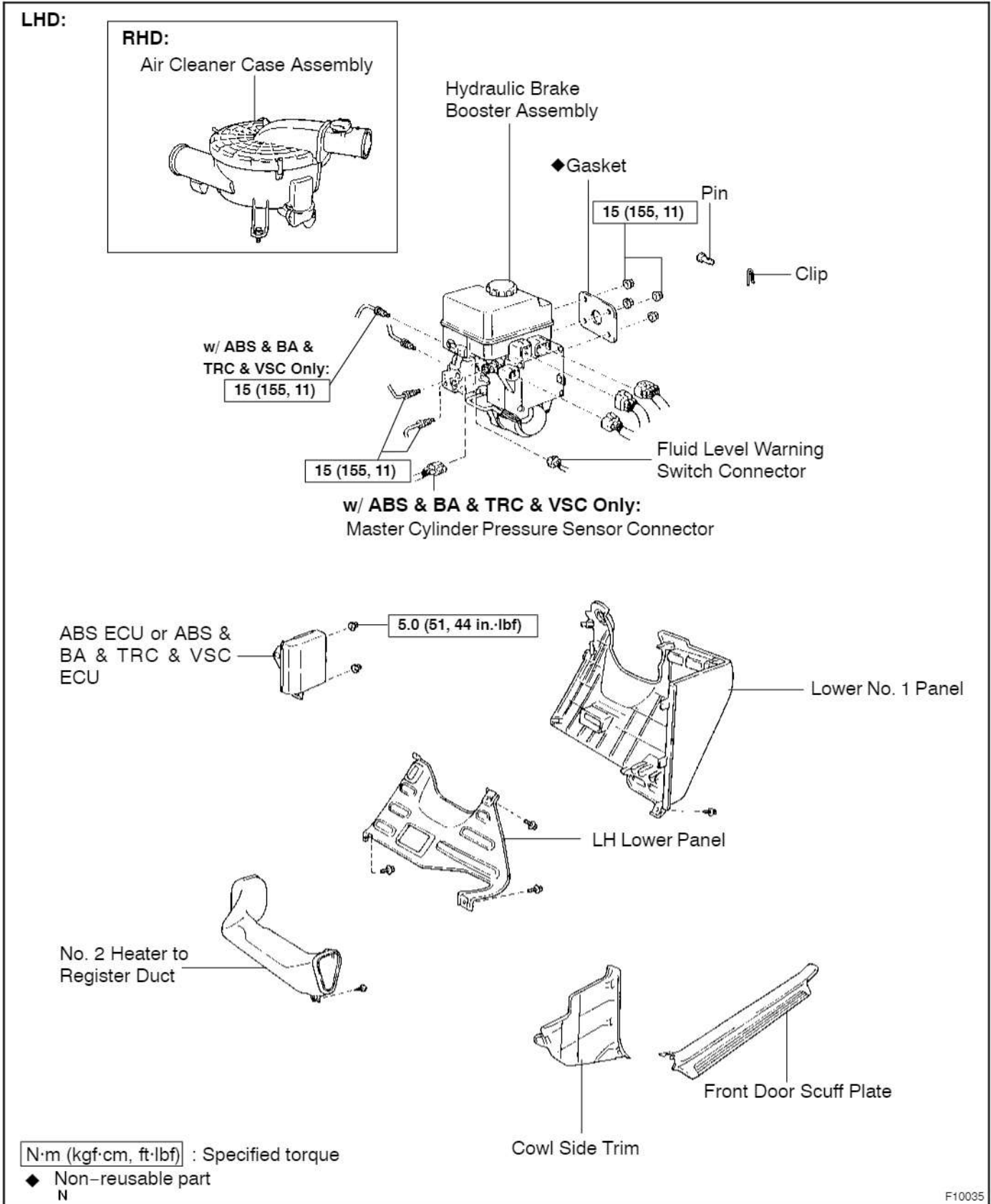

cardiagn.com

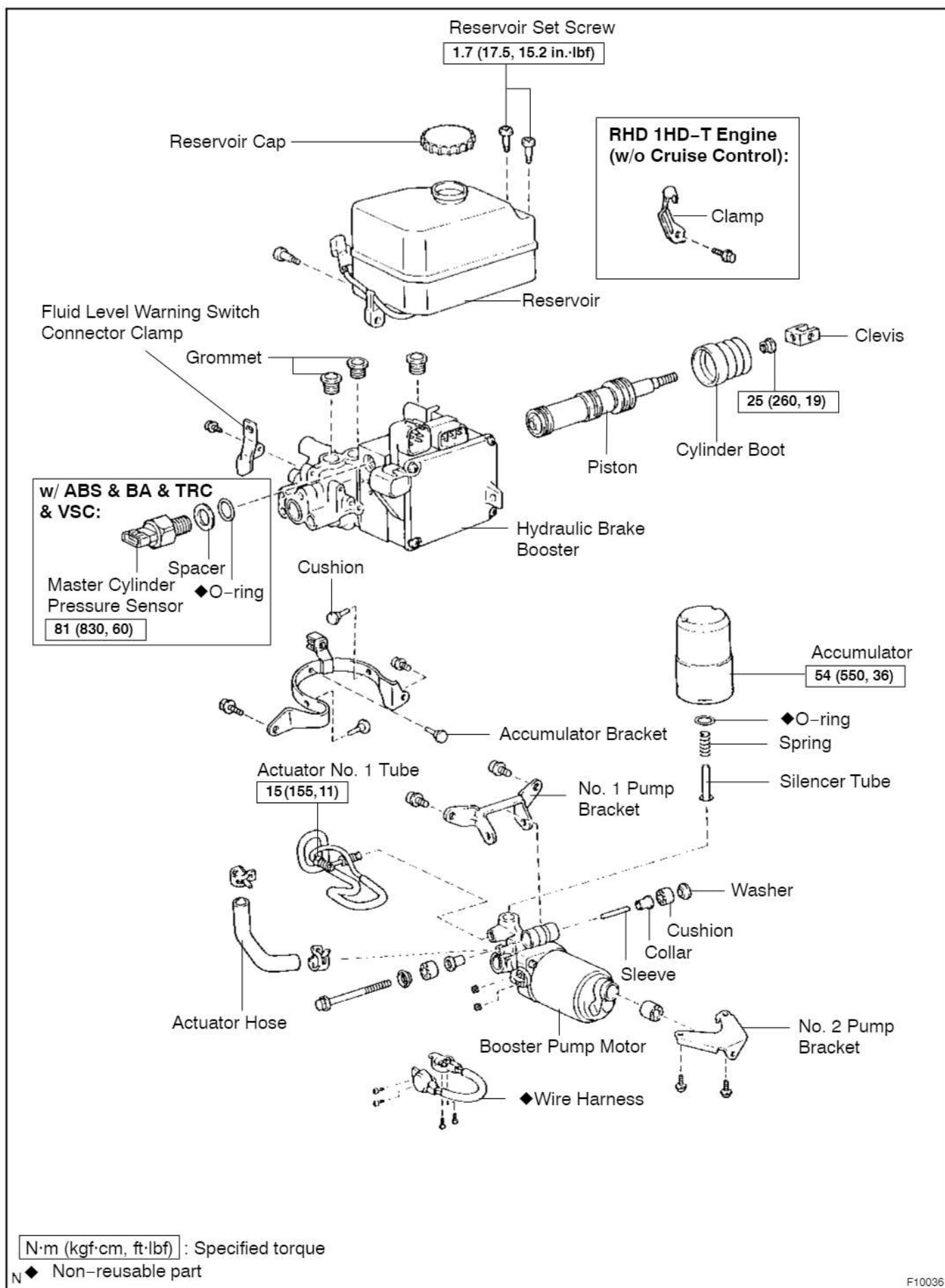

N·m (kgf·cm, ft·lbf) : Specified torque

◆ Non-reusable part

REMOVAL

NOTICE:

Before starting the work, make sure that the ignition switch is OFF and depress the brake pedal more than 40 times.

HINT:

When a pressure in power supply system is released, reaction force becomes light and stroke becomes longer.

NOTICE:

- As high pressure is applied to the brake actuator tube No. 1, never deform it.
- Until the work is over, do not turn the ignition switch ON.

1. DRAW OUT FLUID WITH SYRINGE

NOTICE:

Do not let brake fluid remain on a painted surface. Wash it off immediately.

2. REMOVE SCUFF PLATE, COWL SIDE TRIM, LOWER NO. 1 PANEL, LH LOWER PANEL AND NO. 2 HEATER TO REGISTER DUCT (See Pub. No. RM616E on page BO-127)

3. REMOVE ABS OR ABS & TRC & VSC ECU

Remove the 2 nuts and ABS or ABS & TRC & VSC ECU.

Torque: 5.0 N·m (51 kgf·cm, 44 in·lbf)

4. RHD:

REMOVE AIR CLEANER CASE ASSEMBLY

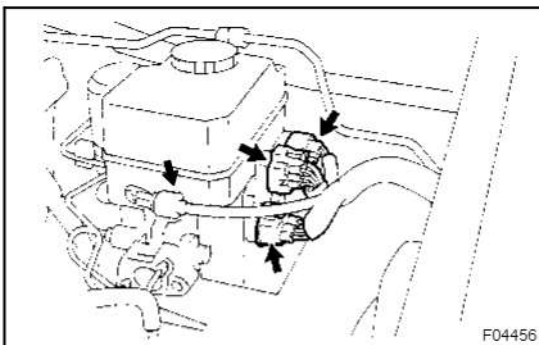

5. w/ ABS only:

DISCONNECT 4 CONNECTORS

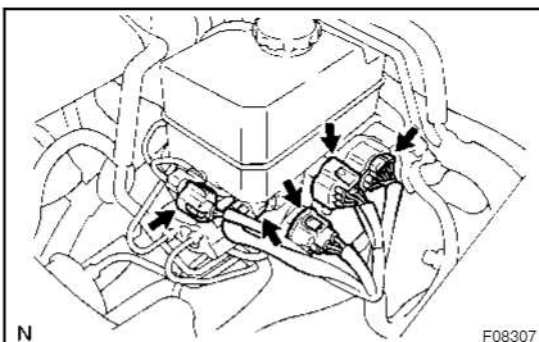

6. w/ ABS & TRC & VSC only:

DISCONNECT 5 CONNECTORS

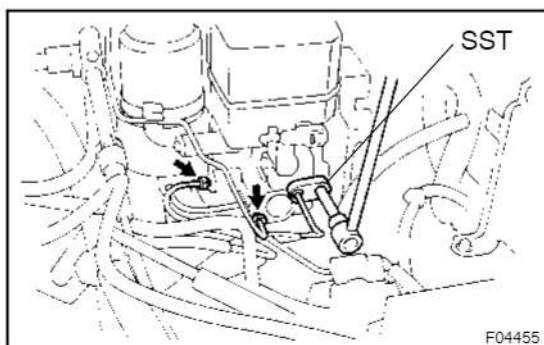

**7. w/ ABS only:
DISCONNECT BRAKE LINES**

Using SST, disconnect the 3 brake lines.

SST 09023-00100

Torque: 15 N·m (155 kgf·cm, 11 ft·lbf)

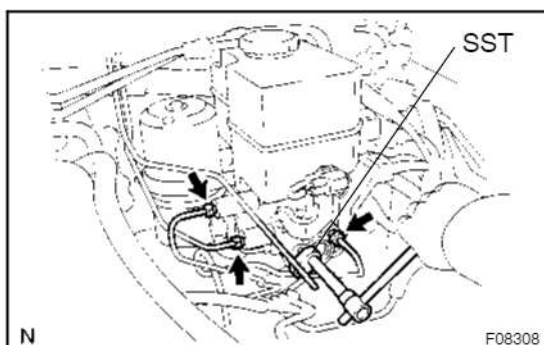

**8. w/ ABS & TRC & VSC only:
DISCONNECT BRAKE LINES**

Using SST, disconnect the 4 brake lines.

SST 09023-00100

Torque: 15 N·m (155 kgf·cm, 11 ft·lbf)

9. REMOVE CLIP AND CLEVIS PIN

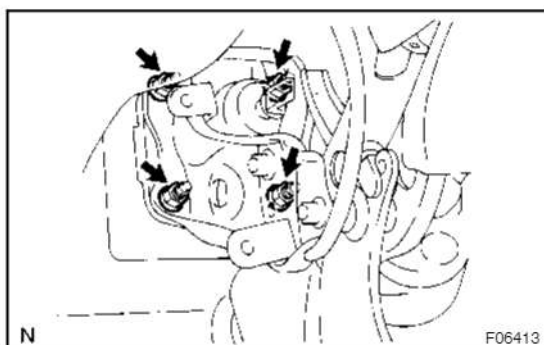

10. REMOVE HYDRAULIC BRAKE BOOSTER ASSEMBLY

(a) Remove the 4 booster installation nuts.

Torque: 15 N·m (155 kgf·cm, 11 ft·lbf)

(b) Remove the booster assembly and gasket.

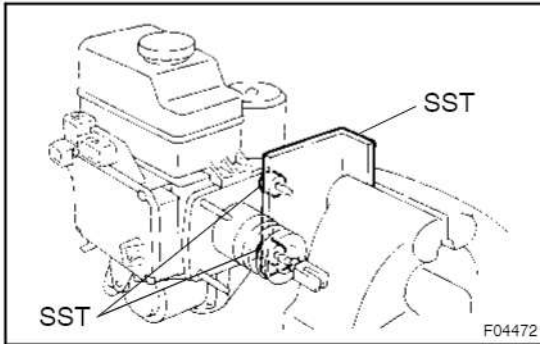

DISASSEMBLY

1. PLACE HYDRAULIC BRAKE BOOSTER IN VISE

Using SST, set the hydraulic brake booster in vise.

SST 09630-00014 (09631-00142),
09950-60010 (09951-00180, 09951-00190)

2. REMOVE FLUID LEVEL WARNING SWITCH CONNECTOR CLAMP

- (a) Disconnect the connector.
- (b) Remove the bolt and clamp.

3. RHD 1HD-T engine w/o cruise control: REMOVE BOLT AND CLAMP

4. REMOVE RESERVOIR AND GROMMETS

- (a) Remove reservoir cap.
- (b) Remove the 3 set screws and pull out the reservoir.

Torque: 1.7 N·m (17.5 kgf·cm, 15.2 in·lbf)

- (c) Remove the 3 grommets.

5. REMOVE CLEVIS AND CYLINDER BOOT

- (a) Loosen the lock nut, then remove the clevis and lock nut.
Torque: 25 N·m (260 kgf·cm, 19 ft·lbf)
- (b) Remove the cylinder boot.

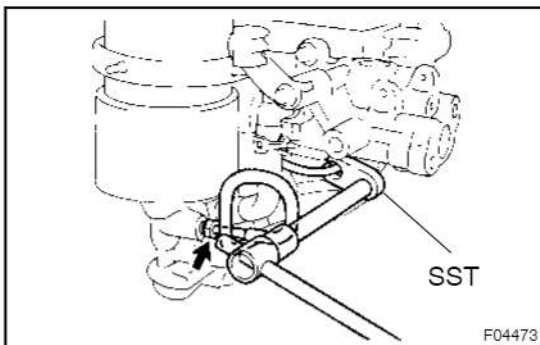

6. REMOVE BRAKE ACTUATOR TUBE NO. 1

Using SST, remove the brake actuator tube No. 1.

SST 09023-00100

Torque: 15 N·m (155 kgf·cm, 11 ft·lbf)

7. REMOVE BOOSTER PUMP AND ASSEMBLY

- (a) Remove the actuator hose.
- (b) Remove the 4 screws and wire harness from the booster and pump.
- (c) Remove the 2 bolts, accumulator bracket.
- (d) Remove the 2 bolts and booster pump motor assembly.
- (e) Remove the bolt and No. 1 pump bracket.
- (f) Remove the 2 washers, 2 cushions, 2 collars and sleeve.
- (g) Remove the 2 bolts and No. 2 pump bracket.
- (h) Remove the cushion from No. 2 pump bracket.

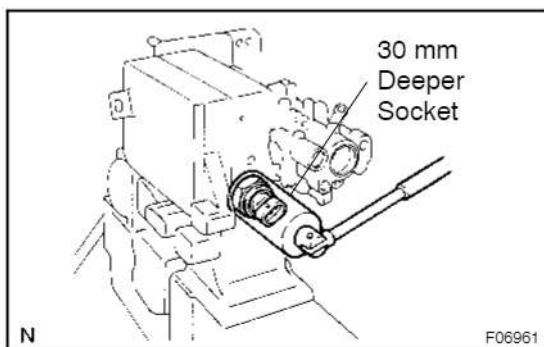
**8. ABS & BA & TRC & VSC only:****REMOVE MASTER CYLINDER PRESSURE SENSOR**

Using 30 mm deeper socket wrench and remove the oil pressure sensor, spacer and O-ring.

Torque: 81 N·m (830 kgf·cm, 60 ft·lbf)

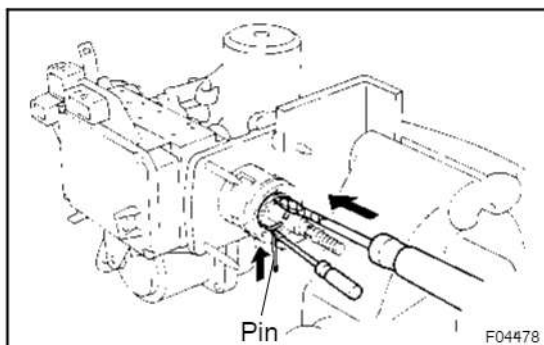
**9. REMOVE PISTON**

- (a) Pressing the piston in with a screwdriver, use a pin or an equivalent to push the snap ring from the hole in the body then remove it with another screwdriver.
- (b) Remove the piston, pulling straight out, not at an angle.

NOTICE:

- If pulled out and installed at an angle, there is a possibility that the cylinder bore could be damaged.
- At the time of reassembly, be careful not to damage the rubber lips on the pistons.

10. REMOVE ACCUMULATOR FROM BOOSTER PUMP

- (a) Using SST, remove the accumulator.

SST 09318-12010

Torque: 54 N·m (550 kgf·cm, 36 ft·lbf)

- (b) Remove the silencer tube, spring and O-ring.

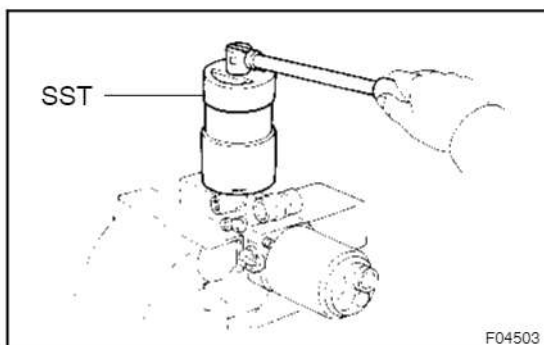

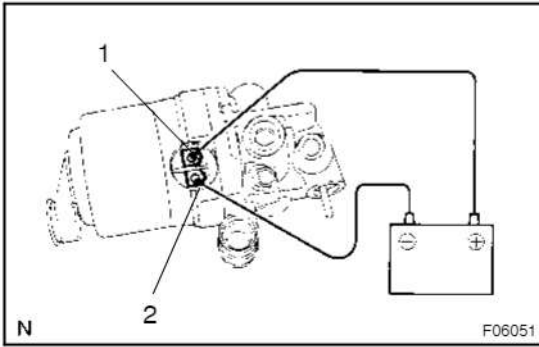

INSPECTION

INSPECT HYDRAULIC BRAKE BOOSTER PUMP MOTOR OPERATION

- (a) Connect the positive (+) lead from the battery to terminal 1 of pump motor, and the negative (-) lead to terminal 2.
- (b) Check that the pump motor operation.

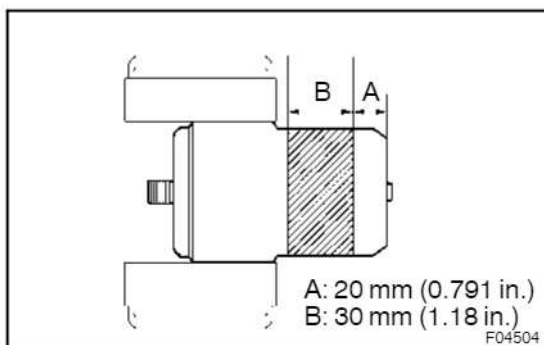

DISPOSAL

DISPOSAL METHOD OF ACCUMULATOR

- (a) Place the accumulator in a vise, cover it with a cloth over.
- (b) Using a saw, then cut the accumulator body slowly.

CAUTION:

Do not cut at a place except a stretch.

- (c) When the outer body of the accumulator is cut, gas discharges.

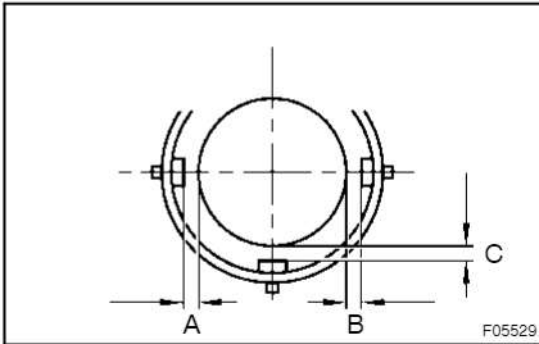

REASSEMBLY

Reassembly is in the reverse order of disassembly (See page BR-30).

INSTALL ACCUMULATOR BRACKET

When installing the accumulator bracket, adjust to secure the clearance shown in the illustration on the left.

Standard clearance:

A + B: 4.1 mm (0.161 in.) or less

C: 0.3 - 3.8 mm (0.012 - 0.150 in.)

HINT:

Secure more than 0.3 mm (0.012 in.) clearance for A and B each.

INSTALLATION

Installation is in the reverse order of removal (See page BR-28).

HINT:

- After installation, fill the brake reservoir with brake fluid and bleed brake system (See page BR-1).
- Check for leaks.

COMBINATION METER CIRCUIT

- (S) : Speedometer (F) : Fuel Receiver Gauge (W) : Water temperature receiver gauge
- (T) : Tachometer (V) : Voltmeter (O) : Oil pressure gauge

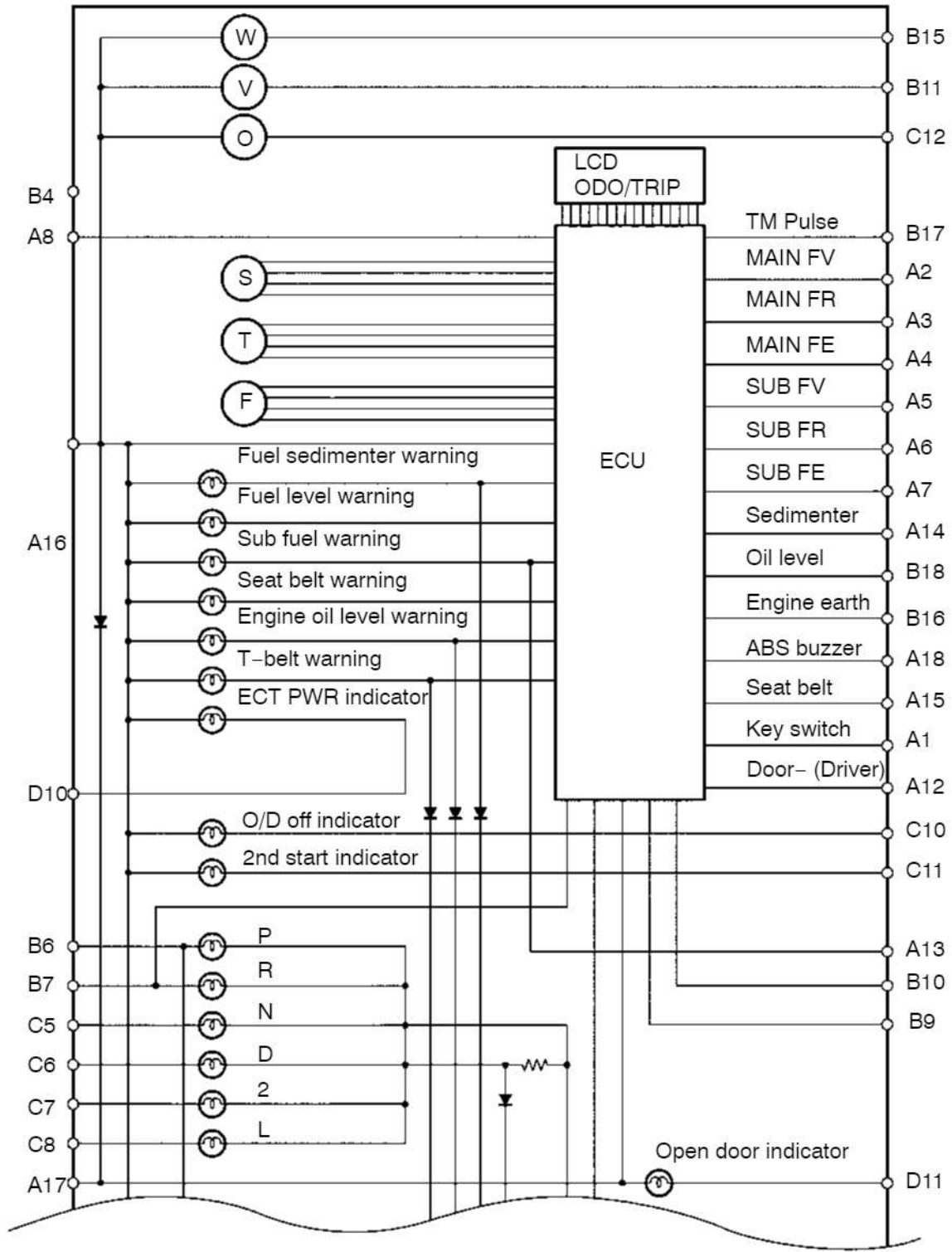

cardiagn.com

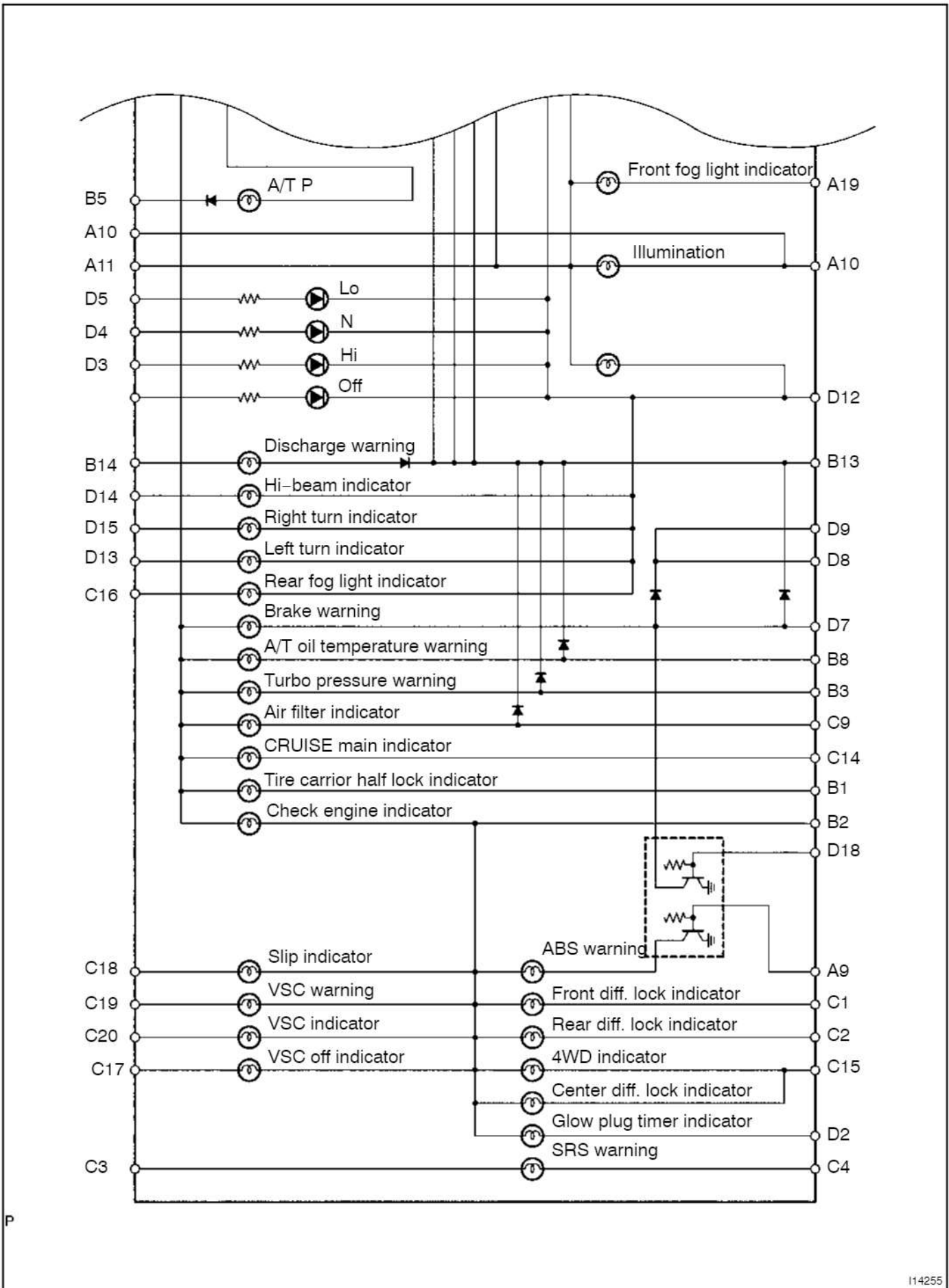

cardiagn.com

BODY ELECTRICAL - COMBINATION METER

No.		Wiring connector side	No.		Wiring connector side
A	1	Key unlock warning switch	C	1	Front diff. lock detection switch
	2	Fuel main sender gauge		2	Rear diff. lock detection switch
	3	Fuel main sender gauge		3	ECU-B fuse
	4	Fuel main sender gauge		4	Center airbag sensor assembly
	5	Fuel sub sender gauge		5	Neutral start switch (N range)
	6	Fuel sub sender gauge		6	Neutral start switch (D range)
	7	Fuel sub sender gauge		7	Neutral start switch (2 range)
	8	Sub fuel switch		8	Neutral start switch (L range)
	9	ABS ECU		9	Air filter warning switch
	10	Light control rheostat		10	O/D main switch
	11	TAIL fuse		11	Engine and ECT ECU
	12	Driver door courtesy switch		12	Low oil pressure warning switch
	13	Engine and ECT ECU		14	Engine and ECT ECU
	14	Fuel sedimenter warning switch		15	Transfer 4WD position switch
	15	Seat belt buckle switch		15	Center diff. lock indicator switch
	16	GAUGE fuse		16	Rear fog light switch
	17	DOME fuse		17	ABS, TRC, VSC ECU
	18	ABS ECU		18	ABS, TRC, VSC ECU
	19	Front fog light switch		19	ABS, TRC, VSC ECU
B	1	Tire half lock indicator switch	D	2	Glow plug timer
	2	Engine and ECT ECU		3	Suspension control ECU
	3	Turbo pressure gauge		4	Suspension control ECU
	4	CIGAR fuse		5	Suspension control ECU
	5	Neutral start switch (P range)		6	Suspension control ECU
	6	Neutral start switch (P range)		7	Brake fluid level warning switch
	7	Neutral start switch (R range)		8	Parking brake switch
	8	A/T oil temperature indicator switch		9	Body control ECU (M/T)
	9	Speed control unit		10	ECT pattern select switch
	10	Speed sensor		11	Body control ECU
	11	Ground		12	Ground
	13	Alternator		13	Turn signal switch (Left)
	14	IGN fuse		14	Headlight dimmer switch
	15	Water temperature sender gauge		15	Turn signal switch (Right)
	16	Ground		18	ABS, TRC, VSC ECU
	17	Engine and ECT ECU			
	18	Engine oil level sensor			

INSPECTION

Connector disconnected:

INSPECT COMBINATION METER CIRCUIT

Connect the connector "A", "B", "C" and "D" to the combination meter and inspect the wire harness side connectors from the back side as shown in the table.

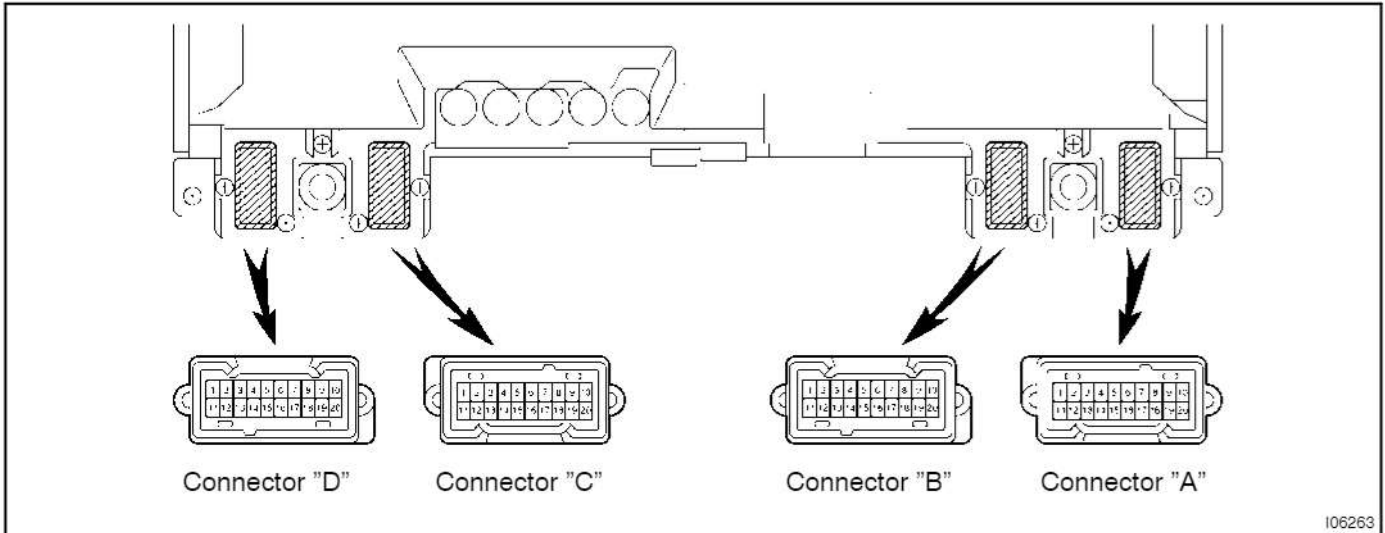

106263

Tester connection	Condition	Specified condition
A1 - Ground	Key unlock warning switch ON (Key is inserted)	No voltage
A1 - Ground	Key unlock warning switch OFF (Key is removed)	Battery voltage
A2 - Ground	Ignition switch ON	4.5 - 5.5 V
A3 - Ground	Ignition switch ON and fuel sender gauge float UP	Approx. 4.5 V
A3 - Ground	Ignition switch ON and fuel sender gauge float DOWN	Approx. 0.5 V
A4 - Ground	Constant	0 V
A5 - Ground	Ignition switch ON	4.5 - 5.5 V
A6 - Ground	Ignition switch ON and fuel sub sender gauge float UP	Approx. 5.5 V
A6 - Ground	Ignition switch ON and fuel sub sender gauge float DOWN	Approx. 0.5 V
A7 - Ground	Constant	0 V
A8 - Ground	Ignition switch ON and sub fuel switch ON	Battery voltage
A8 - Ground	Ignition switch OFF and sub fuel switch OFF	No voltage
A9 - Ground	Ignition switch ON and ABS warning light light up	No voltage
A9 - Ground	Ignition switch ON and ABS warning light does not light up	Battery voltage
A10 - Ground	Ignition switch ON and light control rheostat volume minimum	Analog → Battery voltage Opti → Approx. 8 V (Approx. 8 V at rheostat off)

BODY ELECTRICAL - COMBINATION METER

A10 - Ground	Ignition switch ON and light control rheostat volume maximum	No voltage
A11 - Ground	Light control switch OFF	No voltage
A11 - Ground	Light control switch TAIL or HEAD	Battery voltage
A12 - Ground	Ignition switch ON and driver door is opened	No voltage
A12 - Ground	Ignition switch ON and driver door is closed	Battery voltage
A13 - Ground	Ignition switch ON and sub fuel switch ON	No voltage
A13 - Ground	Ignition switch OFF and sub fuel switch OFF	Battery voltage
A14 - Ground	Ignition switch ON and engine is stopped	No voltage
A14 - Ground	Ignition switch ON and engine is running	Battery voltage
A15 - Ground	Ignition switch ON and seat belt is unfastened	No voltage
A15 - Ground	Ignition switch ON and seat belt is fastened	Battery voltage
A16 - Ground	Ignition switch OFF	No voltage
A16 - Ground	Ignition switch ON	Battery voltage
A17 - Ground	Constant	Battery voltage
A18 - Ground	Ignition switch ON and ABS is error	No voltage
A18 - Ground	Ignition switch ON and ABS is normal	Battery voltage
A19 - Ground	Ignition switch ON and fog light switch OFF	Battery voltage
A19 - Ground	Ignition switch ON and fog light switch ON	No voltage
B1 - Ground	Ignition switch ON and tire carrier is opened	No voltage
B1 - Ground	Ignition switch ON and tire carrier is closed	Battery voltage
B2 - Ground	Ignition switch ON and engine is stopped	No voltage
B2 - Ground	Ignition switch ON and engine is running	Battery voltage
B4 - Ground	Ignition switch OFF	No voltage
B4 - Ground	Ignition switch ACC or ON	Battery voltage
B5 - Ground	Ignition switch ON and A/T shift P indicator light up	No voltage
B5 - Ground	Ignition switch ON and A/T shift P indicator does not light up	Battery voltage
B6 - Ground	Ignition switch ON and except A/T shift P position	No voltage
B6 - Ground	Ignition switch ON and A/T shift P position	Battery voltage
B7 - Ground	Ignition switch ON and except A/T shift R position	No voltage
B7 - Ground	Ignition switch ON and A/T shift R position	Battery voltage
B8 - Ground	Ignition switch ON and A/T oil temperature indicator light up	No voltage
B8 - Ground	Ignition switch ON and A/T oil temperature indicator does not light up	Battery voltage
B9 - Ground	Ignition switch ON and slowly move the wheel	Pulse signal is output below 1.5 V ↔ approx. 5 V or below 1.5 V ↔ Battery voltage
B10 - Ground	Ignition switch ON and slowly move the wheel	Pulse signal is output below 1.5 V ↔ Battery voltage
B11 - Ground	Constant	0 V
B13 - Ground	Ignition switch ON and engine is stopping	No voltage
B13 - Ground	Ignition switch ON and engine is running	Battery voltage

B14 - Ground	Ignition switch OFF	No voltage
B14 - Ground	Ignition switch ON	Battery voltage
B15 - Ground	Ignition switch ON and Water temperature 90 °C	Analog: Approx. 5V Opti: Approx. 2V
B16 - Ground	Constant	0 V
B17 - Ground	Engine is running	Pulse generation
B18 - Ground	Ignition switch ON and engine is running	No voltage
B18 - Ground	Ignition switch ON and engine is stopping	Battery voltage
C1 - Ground	Ignition switch ON and rear diff. lock switch OFF	Battery voltage
C1 - Ground	Ignition switch ON and rear diff. lock switch ON	No voltage
C2 - Ground	Ignition switch ON and rear diff. lock switch OFF	Battery voltage
C2 - Ground	Ignition switch ON and rear diff. lock switch ON	No voltage
C3 - Ground	Constant	Battery voltage
C4 - Ground	Ignition switch ON and airbag indicator light light up	No voltage
C4 - Ground	Ignition switch ON and airbag indicator does not light up	Battery voltage
C5 - Ground	Ignition switch ON and except A/T shift N position	No voltage
C5 - Ground	Ignition switch ON and A/T shift N position	Battery voltage
C6 - Ground	Ignition switch ON and except A/T shift D position	No voltage
C6 - Ground	Ignition switch ON and A/T shift D position	Battery voltage
C7 - Ground	Ignition switch ON and except A/T shift 2nd position	No voltage
C7 - Ground	Ignition switch ON and A/T shift 2nd position	Battery voltage
C8 - Ground	Ignition switch ON and except A/T shift L position	No voltage
C8 - Ground	Ignition switch ON and A/T shift L position	Battery voltage
C10 - Ground	Ignition switch ON and O/D off switch ON	No voltage
C10 - Ground	Ignition switch ON and O/D off switch OFF	Battery voltage
C11 - Ground (M/T vehicle)	Ignition switch ON and ETCS indicator light light up	No voltage
C11 - Ground (M/T vehicle)	Ignition switch ON and ETCS indicator light does not light up	Battery voltage
C12 - Ground	Ignition switch ON and engine is running	Analog: Approx. 6 - 14 V Opti: Approx. 5 - 8 V
C12 - Ground	Ignition switch ON and engine is stopping	Analog: Battery voltage Opti: Approx. 8 V
C13 - Ground	Ignition switch ST position	Battery voltage
C13 - Ground	Ignition switch ON	No voltage
C14 - Ground	Ignition switch ON and cruise control switch OFF	Battery voltage
C14 - Ground	Ignition switch ON and cruise control switch ON	No voltage
C15 - Ground	Ignition switch ON and center diff. lock switch OFF	Battery voltage
C15 - Ground	Ignition switch ON and center diff. lock switch ON	No voltage
C16 - Ground	Rear fog light switch ON	Battery voltage

BODY ELECTRICAL - COMBINATION METER

C16 - Ground	Rear fog light switch OFF	No voltage
C17 - Ground	IG switch ON, off road TRC indicator light ON	Below 1.5 V
	IG switch ON, off road TRC indicator light OFF	10 - 14 V
C18 - Ground	IG switch ON, VSC warning light ON	Below 2.0 V
	IG switch ON, VSC warning light OFF	10 - 14 V
C19 - Ground	IG switch ON, VSC warning light ON	Below 2.0 V
	IG switch ON, VSC warning light OFF	10 - 14 V
C20 - Ground	IG switch ON, VSC OFF indicator light ON	Below 2.0 V
	IG switch ON, VSC OFF indicator light OFF	10 - 14 V
D2 - Ground (Diesel vehicle)	Ignition switch ON and glow indicator light up	No voltage
D2 - Ground (Diesel vehicle)	Ignition switch ON and glow indicator does not light up	Battery voltage
D3 - Ground	Ignition switch ON and HPS indicator light up	Approx. 5 V
D3 - Ground	Ignition switch ON and HPS indicator light does not light up	No voltage
D4 - Ground	Ignition switch ON and HPS switch N	Approx. 5 V
D4 - Ground	Ignition switch ON and HPS switch HI or LO	No voltage
D5 - Ground	Ignition switch ON and HPS switch LO	Approx. 5 V
D5 - Ground	Ignition switch ON and HPS switch N	No voltage
D6 - Ground	Ignition switch ON and HPS system is operating	Approx. 5 V
D6 - Ground	Ignition switch ON and HPS system is OFF	No voltage
D7 - Ground	Ignition switch ON and brake fluid level warning switch float DOWN	No voltage
D7 - Ground	Ignition switch ON and brake fluid level warning switch float UP	Battery voltage
D8 - Ground	Ignition switch ON and parking brake lever is pulled	No voltage
D8 - Ground	Ignition switch ON and parking brake lever is released	Battery voltage
D9 - Ground	Ignition switch ON, parking brake lever is released and brake fluid level warning switch float DOWN	No voltage
D9 - Ground	Ignition switch ON, parking brake lever is released and brake fluid level warning switch float UP	Battery voltage
D10 - Ground	Ignition switch ON and pattern select switch NORM	No voltage
D10 - Ground	Ignition switch ON and pattern select switch PWR	Battery voltage
D11 - Ground	All door is opened	No voltage
D11 - Ground	Either door is closed	Battery voltage
D12 - Ground	Constant	0 V
D13 - Ground	Ignition switch ON and turn signal switch OFF or RIGHT	No voltage
D13 - Ground	Ignition switch ON and turn signal switch LEFT	Battery voltage
D14 - Ground	Light control switch OFF	No voltage
D14 - Ground	Light control switch HI	Battery voltage

D15 - Ground	Ignition switch ON and turn signal switch OFF or LEFT	No voltage
D15 - Ground	Ignition switch ON and turn signal switch RIGHT	Battery voltage
D16 - Ground	Head Light control switch ON	Battery voltage
D16 - Ground	Head Light control switch OFF	No voltage
D18 - Ground	IG switch ON, BRAKE warning light ON	Below 2.0 V
D17 - Ground	Ignition switch ON and washer indicator light ON	No voltage
D17 - Ground	Ignition switch OFF and washer indicator light OFF	Battery voltage
D18 - Ground	IG switch ON, BRAKE warning light OFF	10 - 14 V

If circuit is not as specified, wiring diagram and inspect the circuits connected to other parts.

FRONT WIPER AND WASHER COMPONENTS

801UE-01

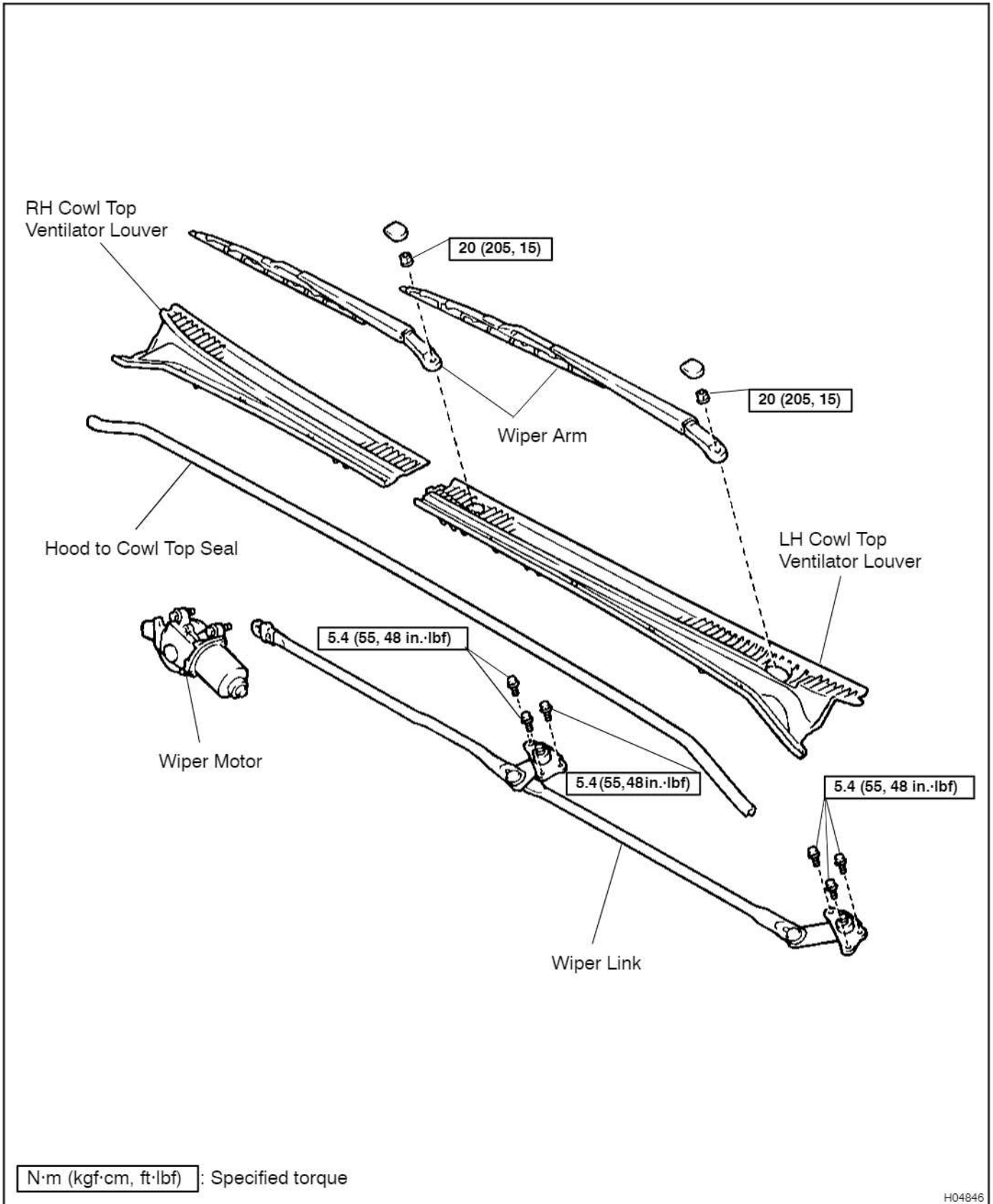

cardiagn.com

REMOVAL

1. REMOVE THESE PARTS:

- (a) Wiper arms
- (b) Hood to cowl top seal

2. REMOVE COWL TOP VENTILATOR LOUVER

- (a) Remove the RH cowl top ventilator louver.
- (b) Remove the LH cowl top ventilator louver.

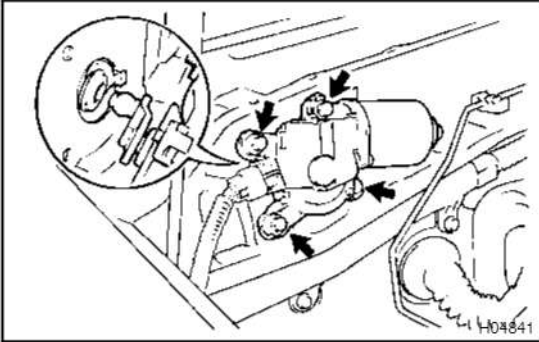

3. REMOVE WIPER MOTOR

- (a) Disconnect the connector, unfasten the 4 bolts.
- (b) Disconnect the wiper motor from the wiper link, then remove the wiper motor.

4. REMOVE WIPER LINK

- (a) Remove the 6 bolts.
- (b) Remove the wiper link through the service hole.

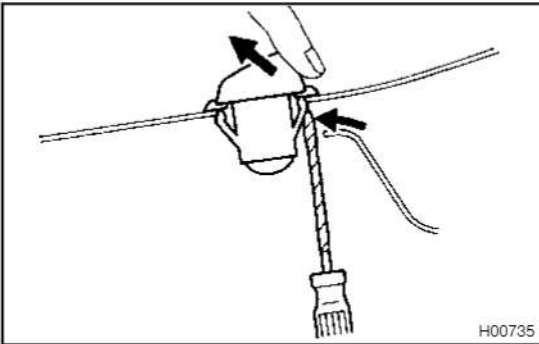

5. REMOVE WASHER NOZZLE

- (a) Disconnect the washer hoses.
- (b) Using a screwdriver, remove the washer nozzles.

HINT:

Tape the screwdriver tip before use.

INSPECTION

INSPECT WASHER NOZZLE

- (a) While operating the washer, check if the point where the washer fluid hits the windshield is within the range indicated by the hatched line.

A: Approx. 259 mm (10.20 in.)

B: Approx. 138 mm (5.43 in.)

C: Approx. 24 mm (0.94 in.)

D: Approx. 108 mm (4.25 in.)

E: Approx. 437 mm (17.20 in.)

F: Approx. 32 mm (1.26 in.)

G: Approx. 24 mm (0.94 in.)

H: Approx. 197 mm (7.76 in.)

I: Approx. 115 mm (4.53 in.)

J: Approx. 395 mm (15.55 in.)

K: Approx. 360 mm (14.17 in.)

L: Approx. 104 mm (4.09 in.)

M: Approx. 121 mm (4.76 in.)

N: Approx. 31 mm (1.22 in.)

O: Approx. 404 mm (15.91 in.)

P: Approx. 181 mm (7.13 in.)

Q: Approx. 26 mm (1.02 in.)

R: Approx. 24 mm (0.94 in.)

S: Approx. 81 mm (3.19 in.)

T: Approx. 185 mm (7.28 in.)

- (b) Check that the lower point where the washer fluid hits the windshield is within the range of the wiping pattern (the area of the glass which is wiped by the blades).

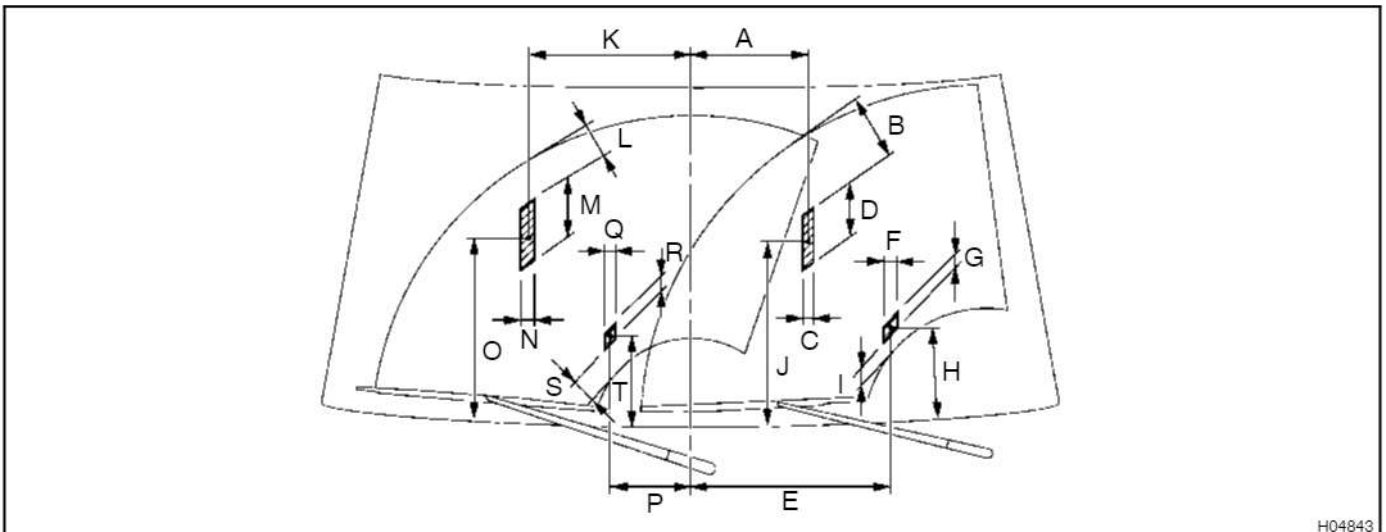

H04843

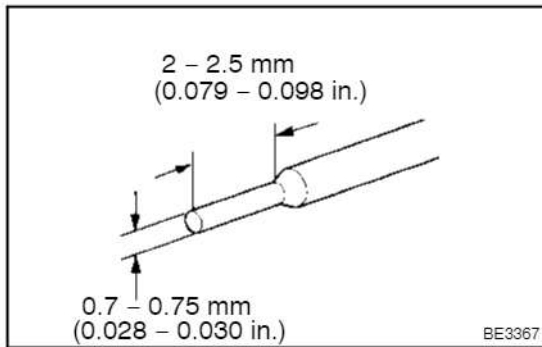

ADJUSTMENT

ADJUST WASHER NOZZLE

Using a tool like the one shown in the illustration, change the direction of the nozzle hole to adjust the point where washer fluid hits the windshield.

INSTALLATION

1. **INSTALL WASHER NOZZLE**
2. **INSTALL WIPER LINK**

Instal the wiper link through the service hole, then torque the 6 bolts.

Torque: 5.4 N·m (55 kgf·cm, 48 in·lbf)

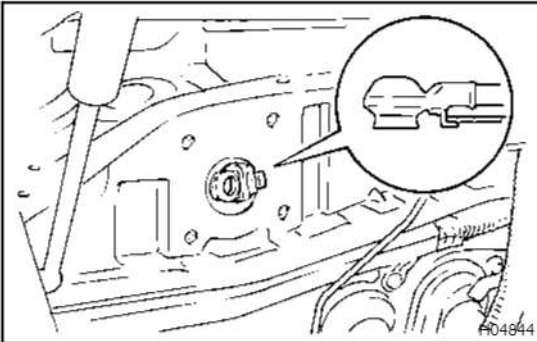

HINT:

When installing the wiper link, connect the claw of wiper link to the panel.

3. **INSTALL WIPER MOTOR**

- (a) Connect the wiper motor to wiper link.
- (b) Install the wiper motor with 4 bolts.
- (c) Connect the connector.

4. **INSTALL COWL TOP VENTILATOR LOUVER**

- (a) Install the LH cowl top ventilator louver.
- (b) Install the RH cowl top ventilator louver.

5. **INSTALL HOOD TO COWL TOP SEAL**

6. **INSTALL WIPER ARM**

- (a) Operate the wipers once and turn the wiper switch OFF.
- (b) Install the wiper arms and tighten nuts by hand.

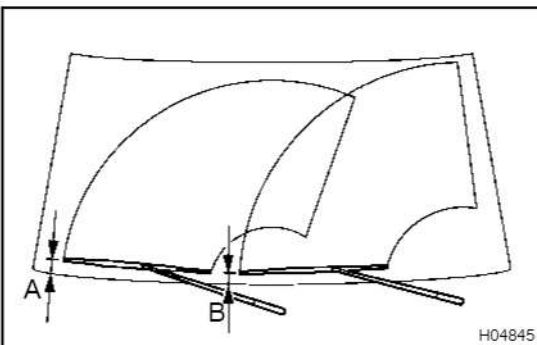

- (c) Adjust the installation position of the wiper arms to the positions shown in the illustration.

A: Approx. 40 mm (1.57 in.)

B: Approx. 26 mm (1.02 in.)

- (d) Torque the nuts.

Torque: 20 N·m (205 kgf·cm, 15 ft·lbf)

- (e) Install the wiper arm caps.